



# CRANE SAFETY

MOUNTAIN CRANE'S GUIDE TO STAYING SAFE

[www.mountaincrane.com](http://www.mountaincrane.com)

801.282.3330 phone | 801.282.0099 fax

# ANY CRANE ANY JOB

CRAWLERS • HYDRAULIC ALL-TERRAIN • ROUGH TERRAIN • HEAVY HAUL

## Table Of Contents

Wire Rope Capacities

Weight Calculation References

Measurement Conversions

Sling Lengths and Loadings

On the Spot Lift Plans

Crane Signals



[www.mountaincrane.com](http://www.mountaincrane.com)

**801.282.3330** phone | **801.282.0099** fax

## SAFE WORKING LOAD OF WIRE ROPE

If a condition should arise where you do not know the safe working strength of a particular size of wire rope, the following "Rule of Thumb Method" can be used. Diameter of the cable in 8ths. Square the top - divide by the bottom and the answer is a safe working load in tons.

**Example: 1/2" cable = 4/8**

$$\frac{4 \times 4}{8} = \frac{16}{8} = 2 \text{ tons safe working load}$$

**7/8" cable**

$$\frac{7 \times 7}{8} = \frac{49}{8} = 6 \text{ tons safe working load}$$

**1-1/8" cable = 9/8**

$$\frac{9 \times 9}{8} = \frac{81}{8} = 10 \text{ tons safe working load}$$

Breaking strength is about 5 times this. This gives us a safety factor of 5 to 1. This formula is for vertical and straight lifts only.

### WIRE ROPE SLING CAPACITY RATING 1 TON = 2000 LBS. SF = 5 TO 1

DIAMETER OF SLING INCHES	STRAIGHT PULL TONS	CHOKER HITCH TONS	BASKET HITCH TONS	SLING ANGLE $\theta=60^\circ$	SLING ANGLE $\theta=45^\circ$	SLING ANGLE $\theta=30^\circ$
1/4	0.56	0.41	1.1	0.97	0.97	0.56
3/8	1.2	0.92	2.5	2.2	1.8	1.2
1/2	2.2	1.6	4.4	3.8	3.1	2.2
5/8	3.4	2.5	6.8	5.9	4.8	3.4
3/4	4.9	3.6	9.7	8.4	6.9	4.9
7/8	6.6	4.5	13.0	11.0	9.3	6.6
1	8.5	6.3	17.0	15.0	12.0	8.5
1-1/8	10.0	7.9	21.0	18.0	15.0	10.0
1-1/4	12.0	10.0	26.0	22.0	18.0	13.0
1-3/8	14.0	12.0	31.0	27.0	22.0	15.0
1-1/2	18.0	14.0	37.0	32.0	26.0	18.0
1-3/4	25.0	19.0	49.0	43.0	35.0	25.0
2	32.0	24.0	64.0	55.0	45.0	32.0

THE ABOVE RATED LOADS ARE BASED ON 6 X 36 AND 6 X 19 CLASSIFICATION, IPS, IWRC, MECHANICALLY SPLICED WIRE ROPE, SLING LOADING BASED ON OSHA STANDARDS 29 CFR 1926/1910 PART 1926.251 1985. SLING RATINGS GOOD FOR D/d RATIOS OF 20 OR GREATER. WHERE D = DIAMETER OF LOAD, d DIAMETER OF SLING COMPONENT WIRE ROPE.

### HITCH TYPES: RATED CAPACITIES BASED ON A SAFETY FACTOR OF 5/1

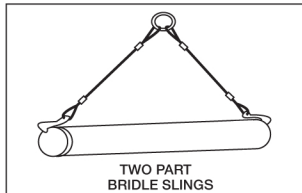
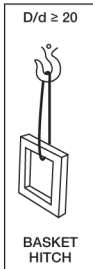
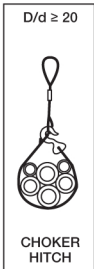
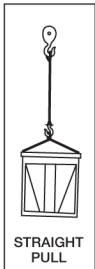

# LIFTING CRANE SAFETY TO NEW HEIGHTS

500 LBS. 577 LBS. 577 LBS. 707 LBS. 707 LBS. 1000 LBS. 1000 LBS.

1000 LBS. 1000 LBS. 1000 LBS. 1000 LBS.

Sling Angle	Load Angle Factor
90°	1.000
85°	1.004
80°	1.015
75°	1.035
70°	1.064
65°	1.104
60°	1.155
55°	1.221
50°	1.305
45°	1.414
40°	1.555
35°	1.742
30°	2.000
25°	2.364
20°	2.924
15°	3.861
10°	5.747
5°	11.49

Load on Sling Leg = Vertical Load x Load Angle Factor

EXAMPLE: Sling Leg at 45 Degree Angle  
 >>Load = 500 LBS. x 1.414  
 >>Load = 707 LBS.

IF YOU FORCE THE EYE DOWN YOU GET SEVERE LOADING IN SLINGS BECAUSE OF LOW SLING ANGLES

CROSBY SHACKLES	Crosby Forged Steel Screwpin Anchor Shackle G 209			Crosby Alloy Forged Steel Bolt Type Anchor Shackle G 2140		
	Nominal Shackle Size Inches	INSIDE LENGTH INCHES	INSIDE WIDTH INCHES	WORKING LOAD LIMIT TONS	INSIDE LENGTH INCHES	INSIDE WIDTH INCHES
3/16	7/8	3/8	1/3			
1/4	1-1/8	1/2	1/2			
5/16	1-7/32	17/32	3/4			
3/8	1-7/16	21/32	1			
7/16	1-11/16	23/32	1-1/2			
1/2	1-7/8	13/16	2			
5/8	2-3/8	1-1/16	3-1/4			
3/4	2-13/16	1-1/4	4-3/4			
7/8	3-5/16	1-7/16	6-1/2			
1	3-3/4	1-11/16	8-1/2			
1-1/8	4-1/4	1-13/16	9-1/2			
1-1/4	4-11/16	2-1/32	12			
1-3/8	5-3/16	2-1/4	13-1/2			
1-1/2	5-3/4	2-3/8	17	5-3/4	2-3/8	30
1-3/4	7	2-7/8	25	7	2-7/8	40
2	7-3/4	3-1/4	35	7-3/4	3-1/4	50
2-1/2	10-1/2	4-1/8	55	10-1/2	4-1/8	80
3				13	5	110
3-1/2				14-5/8	5-1/4	140
4				14-1/2	5-1/2	175

## WEIGHTS OF MATERIALS

Materials & Liquids Pounds /cu.ft.	Weight of 8 x 37 classification wire rope lbs/ft. bright (uncoated) IWRC	Pounds /sq.ft.	Pounds /gal.
Aluminum.....165	• 1/2".....0.46	Steel Plate	Gas.....6.0
Concrete, Reinf.....150	• 3/4".....1.04	• 1/8".....5.11	Diesel.....7.0
Crushed Rock.....95	• 1".....1.85	• 1/4".....10.21	Water.....8.3
River Sand.....120	• 1-1/8".....2.34	• 1/2".....20.42	
Dry Earth, Loose.....75	• 1-1/4".....2.89	• 1".....40.84	• 7.5 gallons of liquid per cubic foot.
Steel,Rolled.....490	• 1-3/8".....3.50	Aluminum Plate	• 27 cubic feet per cubic yard.
Water.....63	• 1-1/2".....4.16	• 1/8".....1.75	
	• 1-3/4".....5.67	• 1/4".....3.50	• 2,000 lb. = 1 US ton
	• 2".....7.39	Lumber	
	• 2-1/2".....11.60	• 3/4" Fir.....2	
	• 3".....16.60	• 3/4" Oak.....4	

### Formulas and Information

- H = Height    • W = Weight    • L = Length    • d = Diameter    • r = 1/2 diameter
- $\pi = 3.14$  (approx.)    • Area of square of rectangle = HW    • Vol. of Cube = HWL
- Area of circle =  $\pi r^2$     • Circumference =  $\pi d$

### Calculating Sides of a Triangle

Pythagorean Theorem: To find R (hypotenuse), knowing the two sides x and y;  
 Given  $R^2 = x^2 + y^2$  .... Example  $4^2 + 3^2 = R^2$  :  $16 + 9 = R^2$  :  $25 + R^2$  :  $R = 5$



**POLYESTER ROUND-SLINGS**

**WLL-LBS**

<b>PART#</b>	<b>COLOR</b>	<b>VERTICAL</b>	<b>CHOKER</b>	<b>BASKET</b>
FTO-1	Purple	2600	2100	5200
FTO-2	Green/Black	5300	4200	10,600
FTO-3	Yellow	8400	6700	16,800
FTO-4	Tan	10,000	8500	21,200
FTO-5	Red	13,000	10,600	26,400
FTO-6	White/Orange	16,800	13,400	33,600
FTO-7	Blue	21,200	17,000	42,400
FTO-8	Grey	31,000	24,800	62,000
FTO-9	Brown	53,000	42,400	106,000
FTO-10	Olive	66,000	52,800	132,000
FTO-11	Black	90,000	72,000	180,000

**EYEBOLTS: STANDARD SHANK LENGTHS - PLAIN & SHOULDER PATTERN**

<b>Stock Numbers</b>		<b>Dimensions - Inches</b>				<b>WLL - Lbs</b>	
<b>Plain Pattern</b>	<b>Shoulder Pattern</b>	<b>Shank</b>		<b>Eye</b>		<b>Capacity in a Straight Pull</b>	<b>Capacity At 45° Pull</b>
		<b>Dia &amp; Thread</b>	<b>Length</b>	<b>LD.</b>	<b>O.D.</b>		
1	21	1/4"-20	1"	3/4"	1-1/4"	500	125
2	22	5/16"-18	1-1/8"	7/8"	1-1/2"	900	225
3	23	3/8"-16	1-1/4"	1"	1-21/32"	1400	350
4	24	7/16"-14	1-3/8"	1-3/32"	1-27/32"	2000	500
5	25	1/2"-13	1-1/2"	1-3/16"	2-1/16"	2600	650
6	26	9/16"-12	1-5/8"	1-9/32"	2-9/32"	3200	750
7	27	5/8"-11	1-3/4"	1-3/8"	2-1/2"	4000	1000
8	28	3/4"-10	2"	1-1/2"	2-13/16"	6000	1500
9	29	7/8"-9	2-1/4"	1-11/16"	3-1/4"	7000	1750
10	30	1"-8	2-1/2"	1-13/16"	3-9/16"	9000	2250
11	31	1-1/8"-7	2-3/4"	2"	4"	12000	2500
12	32	1-1/4"-7	3"	2-3/16"	4-7/16"	15000	3750
14	34	1-1/2"-6	3-1/2"	2-1/2"	5-3/16"	21000	4900

**Only shoulder pattern eyebolts shall be used in angular lifts.**

**POLYESTER ROUND-SLINGS**

**WLL-LBS**

<b>PART#</b>	<b>COLOR</b>	<b>VERTICAL</b>	<b>CHOKER</b>	<b>BASKET</b>
FTO-1	Purple	2600	2100	5200
FTO-2	Green/Black	5300	4200	10,600
FTO-3	Yellow	8400	6700	16,800
FTO-4	Tan	10,000	8500	21,200
FTO-5	Red	13,000	10,600	26,400
FTO-6	White/Orange	16,800	13,400	33,600
FTO-7	Blue	21,200	17,000	42,400
FTO-8	Grey	31,000	24,800	62,000
FTO-9	Brown	53,000	42,400	106,000
FTO-10	Olive	66,000	52,800	132,000
FTO-11	Black	90,000	72,000	180,000

**EYEBOLTS: STANDARD SHANK LENGTHS - PLAIN & SHOULDER PATTERN**

<b>Stock Numbers</b>		<b>Dimensions - Inches</b>				<b>WLL - Lbs</b>	
<b>Plain Pattern</b>	<b>Shoulder Pattern</b>	<b>Shank</b>		<b>Eye</b>		<b>Capacity in a Straight Pull</b>	<b>Capacity At 45° Pull</b>
		<b>Dia &amp; Thread</b>	<b>Length</b>	<b>LD.</b>	<b>O.D.</b>		
1	21	1/4"-20	1"	3/4"	1-1/4"	500	125
2	22	5/16"-18	1-1/8"	7/8"	1-1/2"	900	225
3	23	3/8"-16	1-1/4"	1"	1-21/32"	1400	350
4	24	7/16"-14	1-3/8"	1-3/32"	1-27/32"	2000	500
5	25	1/2"-13	1-1/2"	1-3/16"	2-1/16"	2600	650
6	26	9/16"-12	1-5/8"	1-9/32"	2-9/32"	3200	750
7	27	5/8"-11	1-3/4"	1-3/8"	2-1/2"	4000	1000
8	28	3/4"-10	2"	1-1/2"	2-13/16"	6000	1500
9	29	7/8"-9	2-1/4"	1-11/16"	3-1/4"	7000	1750
10	30	1"-8	2-1/2"	1-13/16"	3-9/16"	9000	2250
11	31	1-1/8"-7	2-3/4"	2"	4"	12000	2500
12	32	1-1/4"-7	3"	2-3/16"	4-7/16"	15000	3750
14	34	1-1/2"-6	3-1/2"	2-1/2"	5-3/16"	21000	4900

**Only shoulder pattern eyebolts shall be used in angular lifts.**

# CALCULATING WEIGHTS

## PRINCIPLES

### CUBES

$$\begin{aligned}\text{WEIGHT} &= \text{volume} \times \text{unit weight} \\ &= \text{length} \times \text{width} \times \text{height} \\ &\quad \times \text{unit weight}\end{aligned}$$

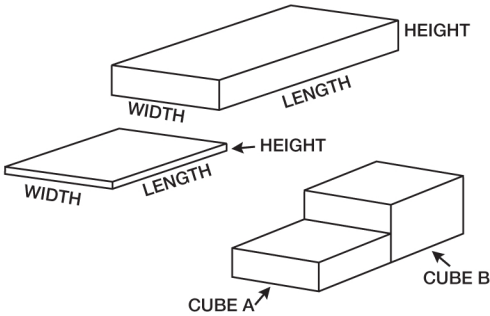

### CYLINDERS

$$\begin{aligned}\text{WEIGHT} &= \text{volume} \times \text{unit weight} \\ &= 3.14 \times \frac{\text{diam.} \times \text{diam.}}{4} \\ &\quad \times \text{length} \times \text{unit weight}\end{aligned}$$

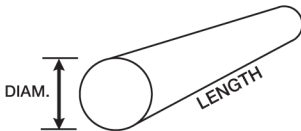

*Taken from Bob's Rigging & Crane Handbook*

# LIFTING CRANE SAFETY TO NEW HEIGHTS

## CALCULATING WEIGHTS

### PRINCIPLES (CONT.)

#### ROUND PLATES



#### WEIGHT

$$= 3.14 \times \frac{\text{diam.} \times \text{diam.}}{4}$$

x thickness x unit weight

#### WEDGE

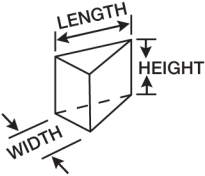

#### WEIGHT

$$= \frac{\text{width} \times \text{length}}{2}$$

x height x unit weight

#### PYRAMID

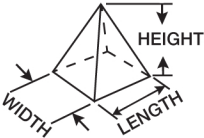

#### WEIGHT solid

$$= \text{width} \times \text{length}$$

$$\times \frac{\text{height}}{3} \times \text{unit weight}$$

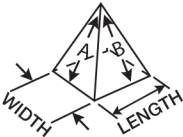

#### WEIGHT hollow (without a base)

$$= (A \times \text{width} + B \times \text{length})$$

x thickness x unit weight

## CALCULATING WEIGHTS

### EXAMPLES (CONT.)

#### 5. TANKS

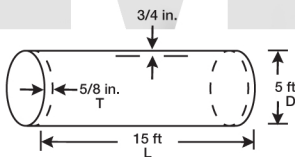

#### 1. VOLUME OF ENDS

$$= 3.14 \times \frac{D \times D}{4} \times T \times 2 \text{ ends}$$

(T = thickness of ends)

$$= 3.14 \times \frac{5 \text{ ft} \times 5 \text{ ft}}{4} \times \frac{5/8 \text{ ft}}{12} \times 2$$

$$= 2.04 \text{ cu. ft}$$

#### 2. VOLUME OF WALL

$$= 3.14 \times D \times L \times T$$

(T = thickness of wall)

$$= 3.14 \times 5 \text{ ft} \times 15 \text{ ft} \times \frac{3/4 \text{ ft}}{12}$$

$$= 14.72 \text{ cu. ft}$$

#### 3. WEIGHT

= volume of ends and wall x unit weight

$$= 2.04 \text{ cu. ft} + 14.72 \text{ cu. ft} \times 490 \text{ lbs}$$

$$= 8,212 \text{ lbs}$$

*Taken from Bob's Rigging & Crane Handbook*

# LIFTING CRANE SAFETY TO NEW HEIGHTS

## CALCULATING WEIGHTS

### PRINCIPLES (CONT.)

#### TANKS

*For steel tanks*

#### 1. CALCULATE VOLUME OF ENDS

$$= 3.14 \times \frac{\text{diam} \times \text{diam}}{4} \times \text{thickness}$$

x 2 ends

#### 2. CALCULATE VOLUME OF WALL

$$= 3.14 \times \text{diam.} \times \text{length} \times \text{thickness}$$

#### 3. WEIGHT

$$= \text{volume of ends} + \text{wall} \\ \times \text{unit weight}$$

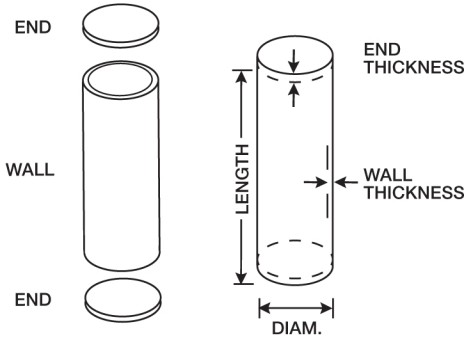

# CALCULATING WEIGHTS

## PRINCIPLES (cont.)

### PYRAMID (cont.)

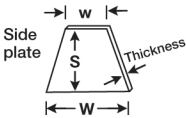
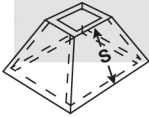

**WEIGHT** hollow (without a base)  
 = total volume of side plates x unit weight

Volume of each side plate =  

$$\frac{W + w}{2} \times S \times \text{thickness}$$

### CONE

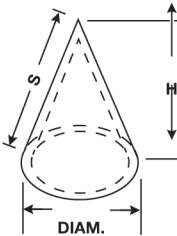

**WEIGHT** solid  
 =  $3.14 \times \frac{\text{diam.} \times \text{diam.}}{4}$   
 x  $\frac{\text{height}}{3}$  x unit weight

**WEIGHT** hollow (without a base)  
 =  $3.14 \times \frac{\text{diam.}}{2} \times S$

x thickness x unit weight



**WEIGHT** hollow (without a base)  
 =  $3.14 \times \frac{(D + d)}{2} \times S$   
 x thickness x unit weight

*Taken from Bob's Rigging & Crane Handbook*

# LIFTING CRANE SAFETY TO NEW HEIGHTS

## CALCULATING WEIGHTS

### PRINCIPLES (CONT.)

#### PIPE

##### METHOD 1.

for thin walled piping

1. Split pipe and lay flat

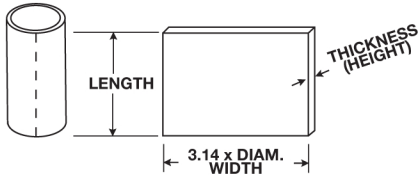

2. Weight

$$= 3.14 \times \text{diam.} \times \text{length} \\ \times \text{thickness} \times \text{unit weight}$$

##### METHOD 2.

for heavy walled pipe  
such as concrete pipe

1. Calculate volume of pipe without a hole
2. Calculate volume of hole
3. Subtract 2 from 1
4. Multiply by unit weight to get weight of pipe

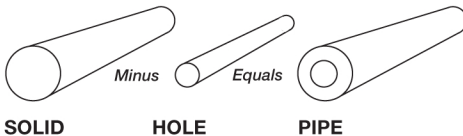

# CALCULATING WEIGHTS

## EXAMPLES (CONT.)

### 3. PIPE (cont.)

REINFORCED  
CONCRETE

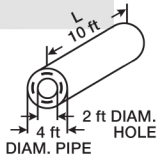

#### METHOD 3

1. SPLIT PIPE AND LAY FLAT

2. WIDTH OF SLAB

$$= 3.14 \times \text{♅ of wall}$$

$$= 3.14 \times 3 \text{ ft}$$

3. WEIGHT

$$= 3.14 \times 3 \text{ ft} \times 10 \text{ ft} \times 1 \text{ ft}$$

$$\times 150 \text{ lbs}$$

$$= 14,130 \text{ lbs}$$

### 4. BALLS

STEEL (SOLID)

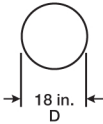

WEIGHT

$$= 3.14 \times \frac{D \times D \times D}{6} \times \text{unit weight}$$

$$= 3.14 \times \frac{1.5 \text{ ft} \times 1.5 \text{ ft} \times 1.5 \text{ ft}}{6}$$

$$\times 490 \text{ lbs}$$

$$= 865.4 \text{ lbs}$$

STEEL (HOLLOW)

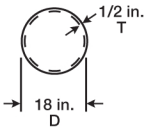

WEIGHT

$$= 3.14 \times D \times D \times T \times \text{unit weight}$$

$$= 3.14 \times 1.5 \text{ ft} \times 1.5 \text{ ft} \times \frac{1/2 \text{ ft}}{12}$$

$$\times 490 \text{ lbs}$$

$$= 144 \text{ lbs}$$

*Taken from Bob's Rigging & Crane Handbook*

# LIFTING CRANE SAFETY TO NEW HEIGHTS

## CALCULATING WEIGHTS

### EXAMPLES (cont.)

#### 3. PIPE

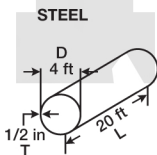

#### METHOD 1

##### WEIGHT

$$\begin{aligned} &= 3.14 \times D \times L \times T \times \text{unit weight} \\ &= 3.14 \times 4 \text{ ft} \times 20 \text{ ft} \times \frac{1/2 \text{ ft}}{12} \\ &\quad \times 490 \text{ lbs} \\ &= 5,128 \text{ lbs} \end{aligned}$$

#### REINFORCED CONCRETE

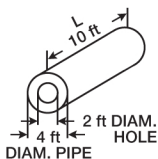

$D_p$  = PIPE DIAM.  
 $D_H$  = HOLE DIAM.

#### METHOD 2

##### 1. VOLUME OF PIPE (without hole)

$$\begin{aligned} &= 3.14 \times \frac{D_p \times D_p \times L}{4} \\ &= 3.14 \times \frac{4 \text{ ft} \times 4 \text{ ft} \times 10 \text{ ft}}{4} \\ &= 125.6 \text{ cu. ft} \end{aligned}$$

##### 2. VOLUME OF HOLE

$$\begin{aligned} &= 3.14 \times \frac{D_H \times D_H \times L}{4} \\ &= 3.14 \times \frac{2 \text{ ft} \times 2 \text{ ft} \times 10 \text{ ft}}{4} \\ &= 31.4 \text{ cu. ft} \end{aligned}$$

##### 3. VOLUME OF PIPE

$$\begin{aligned} &= 125.6 \text{ cu. ft} - 31.4 \text{ cu. ft} \\ &= 94.2 \text{ cu. ft} \end{aligned}$$

##### 4. WEIGHT OF PIPE

$$\begin{aligned} &= 94.2 \text{ cu. ft} \times 150 \text{ lbs} \\ &= 14,130 \text{ lbs} \end{aligned}$$

# CALCULATING WEIGHTS

## PRINCIPLES (cont.)

### PIPE (cont.)

#### METHOD 3.

For heavy walled pipe such as concrete pipe

1. Split pipe and lay flat
2. Calculate width of slab  
=  $3.14 \times \text{diam. of } \phi \text{ of wall}$
3. WEIGHT = width x length x thickness  
x unit weight

$\phi$  = Center line

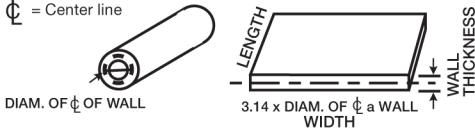

$$= \frac{\text{pipe diam.} + \text{hole diam.}}{2}$$

### BALLS

WEIGHT solid ball

$$= 3.14 \times \frac{\text{diam} \times \text{diam} \times \text{diam}}{6}$$

x unit weight



WEIGHT hollow ball

$$= 3.14 \times \text{diam} \times \text{diam}$$

x thickness of wall x unit weight

*Taken from Bob's Rigging & Crane Handbook*

# LIFTING CRANE SAFETY TO NEW HEIGHTS

## CALCULATING WEIGHTS

### EXAMPLES

#### 1. CUBES

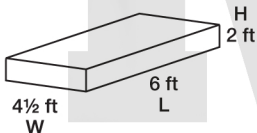

**WEIGHT**  
= L x W x H x unit weight  
= 6' x 4 1/2' x 2' x 150 lbs  
= 8,100 lbs

#### REINFORCED CONCRETE

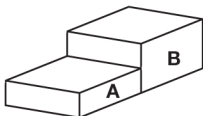

Calculate each cube (A&B) and add

#### 2. CYLINDERS

##### STEEL

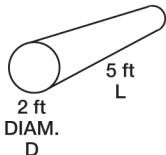

**WEIGHT**  
=  $3.14 \times \frac{D \times D}{4} \times L \times \text{unit weight}$   
=  $3.14 \times \frac{2' \times 2'}{4} \times 5' \times 490 \text{ lbs}$   
= 7,693 lbs

##### REINFORCED CONCRETE

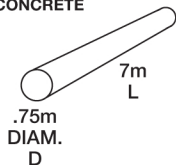

**WEIGHT**  
=  $3.14 \times \frac{D \times D}{4} \times L \times \text{unit weight}$   
=  $3.14 \times \frac{.75\text{m} \times .75\text{m}}{4} \times 7\text{m} \times 2,400 \text{ kg}$   
= 7,420 kg

Taken from Bob's Rigging & Crane Handbook

## CALCULATING WEIGHTS

### PRINCIPLES (cont.)

#### STRUCTURAL SHAPES

CALCULATE WEIGHT OF EACH PART  
AND ADD THEM

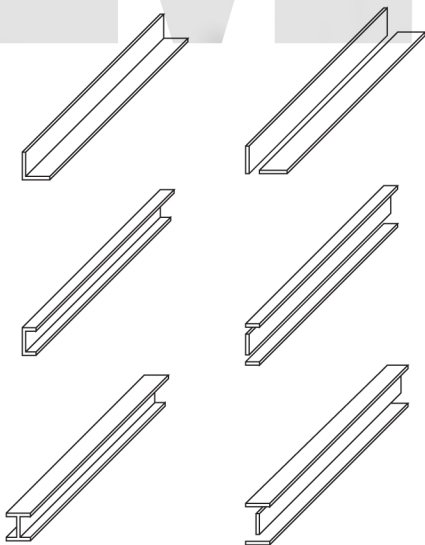

OR  
OBTAIN WEIGHT PER FOOT FOR ANGLES,  
CHANNELS, BEAMS FROM  
A STEEL HANDBOOK

*For reinforcing rods*  
CALCULATE AS CYLINDER OR  
SEE A STEEL HANDBOOK

*Taken from Bob's Rigging & Crane Handbook*

# LIFTING CRANE SAFETY TO NEW HEIGHTS

## Weight Tables

<b>Weights of Materials (Based on Volume)</b>	
<b>Material</b>	<b>Approximate Weight Lbs. Per Cubic Ft.</b>
Aluminum	165
Brass	535
Bronze	500
Copper	560
Iron	480
Lead	710
Steel	490
Tin	460
Steel Plate per 1" of thickness	40
Douglas Fir	50
Pine	30
Oak	59
Maple	44
Hickory	53
Walnut	38
Gasoline	45.9
Oil	58
Crude Oil	53.1
Diesel Fuel	52.1
Water	62.4
Ethylene Glycol (Antifreeze)	69.5
Dirt	125
Concrete	200

**1 Cubic Yard = 27 Cubic Feet**

### Weights of Seamless and Welded Pipe

Nominal Pipe Size	Schedule Number											
	STD	X.S.	10	20	30	40	60	80	100	120	140	180
	WT.	WT.	WT.	WT.	WT.	WT.	WT.	WT.	WT.	WT.	WT.	WT.
2"	3.65	5.02				3.65		5.02				7.46
2.5"	5.79	7.66				5.79		7.66				10.01
3"	7.58	10.25				7.58		10.25				14.31
3.5"	9.11	12.51				9.11		12.51				
4"	10.79	14.98				10.79		14.98		18.98		22.52
5"	14.62	20.78				14.62		20.78		27.04		32.96
6"	18.97	28.57				18.97		28.57		36.42		45.34
8"	28.55	43.39		22.36	24.70	28.55	35.66	43.39	50.93	60.69	67.79	74.71
10"	40.48	54.74		28.04	34.24	40.48	54.74	64.40	77.00	89.27	104.13	115.65
12"	49.56	65.42		33.38	43.77	53.46	73.22	88.57	107.29	125.47	139.68	160.33
14"	54.57	72.09	36.71	45.68	54.57	63.37	85.01	106.13	130.79	150.76	170.22	189.15
16"	62.58	82.77	42.05	52.36	62.58	82.77	107.54	136.58	164.86	192.40	223.57	245.22



Pipe weights shown above are given for a lineal foot of plain end pipe.  
To convert lbs/ft to metric: 1 lb/ft = 149 kg/m

### Weights of Seamless and Welded Pipe

Nominal Pipe Size	Schedule Number											
	STD	X.S.	10	20	30	40	60	80	100	120	140	180
	WT.	WT.	WT.	WT.	WT.	WT.	WT.	WT.	WT.	WT.	WT.	WT.
18"	70.59	93.45	47.39	59.03	82.06	104.76	138.17	170.84	208.00	244.14	274.30	308.55
20"	78.60	104.13	52.73	78.60	104.13	123.06	166.50	208.92	256.15	296.37	341.10	379.14
22"	86.61	114.81	58.07	86.61	114.81		197.42	250.82	302.88	353.61	403.01	451.07
24"	94.62	125.49	63.41	94.62	140.80	171.17	238.29	293.53	367.45	429.50	483.24	542.09
26"	102.63	136.17	85.73	136.17								
28"	110.64	146.85	92.41	146.85	182.73							
30"	118.65	157.53	99.08	157.53	196.08							
32"	126.66	168.21	105.76	168.21	209.43	229.92						
34"	134.67	178.89	112.43	178.89	222.78	244.60						
36"	142.68	189.57	119.11	189.57	236.13	282.36						
42"	166.71	221.61		221.61	276.17	330.41						

Pipe weights shown above are given for a lineal foot of plain end pipe.  
To convert lbs/ft to metric: 1 lb/ft = 149 kg/m

## LIFTING CRANE SAFETY TO NEW HEIGHTS

<b>Vertical, Choker or Vertical Basket</b>			
Rated Capacity shown in tons of 2000 lbs. Rated capacities shown are for 6 x 19 and 6 x 36 improved plow steel wire rope			
Rope Diameter Inches			
	Vertical	Choker	Basket
1/4"	0.56	0.41	1.1
5/16"	0.87	0.64	1.7
3/8"	1.2	0.92	2.5
7/16"	1.7	1.2	3.4
1/2"	2.2	1.6	4.4
9/16"	2.8	2	5.5
5/8"	3.4	2.5	6.8
3/4"	4.9	3.6	9.7
7/8"	6.6	4.8	13
1"	8.5	6.3	17
1 1/8"	10	7.9	21
1 1/4"	13	10	26
1 3/8"	15	12	31
1 1/2"	18	14	37
1 5/8"	21	16	43
1 3/4"	25	19	49
1 7/8"	28	21	56
2"	32	24	64
2 1/8"	35	27	69
2 1/4"	39	30	77
2 3/8"	43	33	86
2 1/2"	47	37	94
2 5/8"	52	40	104
2 3/4"	57	44	113
2 7/8"	61	48	123
3"	67	52	133
3 1/8"	72	56	144
3 1/4"	77	60	154
3 3/8"	83	64	165
3 1/2"	88	69	177

## Decimals

$$.1 = \frac{1}{10}$$

$$.01 = \frac{1}{100}$$

$$.001 = \frac{1}{1000}$$

## To change inches into feet

Divide by 12

e.g.  $39 \text{ ins.} = \frac{39}{12} \text{ ft.}$  or 3.25 ft.

$\frac{5}{8} \text{ ins.} = \frac{5/8}{12} \text{ ft.}$  or  $\frac{.625}{12}$  or .052 ft.

## Parts of a foot in decimals

1 in. = .083 ft.

7 in. = .583 ft.

2 in. = .167 ft.

8 in. = .667 ft.

3 in. = .250 ft.

9 in. = .750 ft.

4 in. = .333 ft.

10 in. = .833 ft.

5 in. = .417 ft.

11 in. = .917 ft.

6 in. = .500 ft.

12 in. = 1.000 ft.

## Rounding off

Can be done and be correct enough for the job.

- Generally use first 4 numbers and the rest 0's  
e.g. 7,834,421 use 7,834,000  
242.346 use 242.3
- If 5th number is 1 to 4 leave 4th number as is.  
If 5th is 5 to 9 add 1 to 4th number  
e.g. 65973 use 65970  
65976 use 65980

## LIFTING CRANE SAFETY TO NEW HEIGHTS

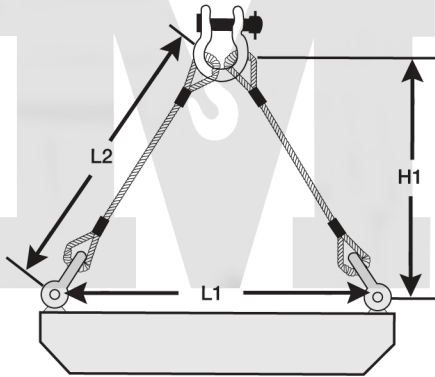

## SLING LENGTHS AND LOADINGS

Sling Angle (deg)	Sling Length (L2)	Rigging Height (H1)	Tension in Each Sing (T)
30	=L1 * 0.577	=L1 * 0.289	=W* 1.00
35	=L1 * 0.610	=L1 * 0.350	=W* 0.87
40	=L1 * 0.653	=L1 * 0.420	=W* 0.78
45	=L1 * 0.707	=L1 * 0.500	=W* 0.71
50	=L1 * 0.778	=L1 * 0.596	=W* 0.65
55	=L1 * 0.872	=L1 * 0.714	=W* 0.61
60	=L1 * 1.000	=L1 * 0.866	=W* 0.58
65	=L1 * 1.183	=L1 * 1.072	=W* 0.55
70	=L1 * 1.462	=L1 * 1.374	=W* 0.53
75	=L1 * 1.932	=L1 * 1.866	=W* 0.52
80	=L1 * 2.879	=L1 * 2.836	=W* 0.51

If the weight of the object and the attachment points are known, use the above table to calculate rigging needs.

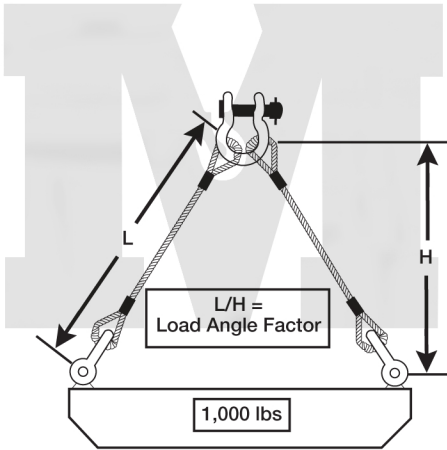

Sling Angle	Load Factor	Sling Angle	Load Factor
90 Deg.	1.000	45 Deg.	1.414
85 Deg.	1.004	40 Deg.	1.555
80 Deg.	1.015	35 Deg.	1.742
75 Deg.	1.035	30 Deg.	2.000
70 Deg.	1.064	25 Deg.	2.364
65 Deg.	1.104	20 Deg.	2.924
60 Deg.	1.155	15 Deg.	3.861
55 Deg.	1.221	10 Deg.	5.747
50 Deg.	1.305	5 Deg.	11.490

In this example, both slings support half the load or 500 pounds. Due to sling angles, a load factor must be applied to account for mechanical tension in the slings. The LOAD ANGLE FACTOR is calculated as follows.

$$\frac{L = 25'}{H = 21.25'} = \frac{25'}{21.25'} = 1.176$$

**Sling angle is near 60 degrees**

**500 lbs x 1.176 = 588 lbs per sling**

LIFTING CRANE SAFETY TO NEW HEIGHTS

# LIFTING CRANE SAFETY TO NEW HEIGHTS

## Crane Wire Rope Replacement Criteria

### Standard Crane Wire Rope

---

- 1) In running ropes, six (6) randomly distributed broken wires in one lay, or three (3) broken wires in one stand in one lay.
- 2) One outer wire broken at contact point with the core of the rope which has worked its way out of the ropes structure and protrudes or loops out from the rope structure.
- 3) Wear of one third of the original diameter of outside individual wires.
- 4) Kinking, crushing, birdcaging or any other damage resulting in distortion of the ropes structure.
- 5) Evidence of any heat damage from any cause.
- 6) Valley breaks

### Rotation Resistant Wire Ropes

---

- 1) Two (2) broken wires in six (6) rope diameters or four (4) broken wires in thirty (30) rope diameters.
- 2) One outer wire broken at contact point with the core of the rope which has worked its way out of the ropes structure and protrudes or loops out from the rope structure.
- 3) Wear of one third of the original diameter of outside individual wires.
- 4) Kinking, crushing, birdcaging or any other damage resulting in distortion of the ropes structure.
- 5) Evidence of any heat damage from any cause.

## **Replacement Criteria for Slings**

### **Synthetic Web Sling Replacement Criteria**

1. Acid or caustic burns.
2. Melted or charred.
3. Snags, punctures, tears or cuts.
4. Distorted, cracked or broken fittings.
5. Broken or worn stitches.
6. Excessive abrasion - visible red warning fibers.
7. Tag missing or is illegible.
8. Pitting corrosion of fittings.
9. Ultraviolet sunlight damage.
10. Other apparent damage which reduces the strength and efficiency of the sling.

### **Wire Rope Slings**

1. Missing or illegible tags
2. 10 randomly distributed broken wires in one rope lay or 5 broken wires in one strand in one rope lay.
3. Kinking, crushing, birdcaging or other damage resulting in deterioration of the wire rope structure.
4. Evidence of heat damage.
5. Damaged end attachments.
6. Sever corrosion or pitting of the wires.
7. Hooks opened more than 15% of the normal throat opening or bent more than 10 degrees from the plane of the hook.
8. For multi-part slings with less than 8-part and cable laid, 20 broken wires in one rope lay, 20 per braid in one rope lay, or more broken strand.
9. For multi-part slings with 8-parts or more, 40 broken wires in one rope lay, 40 per braid in one rope lay, or one broken strand

## Replacement Criteria for Hardware

### Hardware Inspection

1. Significant deformation.
2. More than 5% wear throat or eye of hook and other critical areas of hardware. More than 10% wear in other areas.
3. Cracks, nicks, or gouges.
4. Any modification by cutting or welding
5. Substituted shackle pin.
6. Evidence of heating or bending.
7. Improperly installed hardware or malfunction of items such as safety latches, locking devices, swivel bearing and installation of wire rope clips and wedge sockets.

## INSPECTION OF FITTINGS WEAR







Date \_\_\_\_\_

1. Description of lifted object(s) \_\_\_\_\_  
\_\_\_\_\_
2. Weight of object to be lifted \_\_\_\_\_
3. How was the weight of the object obtained? \_\_\_\_\_  
\_\_\_\_\_
4. Crane Info.            Make \_\_\_\_\_  
                                  Model \_\_\_\_\_  
                                  Equipment Number \_\_\_\_\_  
                                  Serial Number \_\_\_\_\_

- |   |  |
|---|--|
| 5. Total deductions for crane--jib, wire rope, block, ball, etc.....  |  |
| 6. Total weight of all rigging (slings, shackles, bars, etc.) used in the lift.....                                 |  |
| <b>7. Total lifted load. Determined by adding lines 2,5,6.....</b>  |  |
| 8. What is the planned radius of the lift. (at the longest point).....  |  |
| 9. What is the rated capacity of the crane you were using at the radius listed above?.....                          |  |
| 10. Divide line 7 by 9 for percent of load chart used. If over 75% of chart, a critical lift plan is necessary..... |  |

**All employees involved must sign off on the lines provided below.**

\_\_\_\_\_  
\_\_\_\_\_  
\_\_\_\_\_ Supt \_\_\_\_\_

**Note: Use the back of this page to write a lift specific Job Hazard Analysis.**

# LIFTING CRANE SAFETY TO NEW HEIGHTS

Date \_\_\_\_\_

## On the Spot Lift Plan Hazard Analysis

Operation: \_\_\_\_\_

Procedure: (1) \_\_\_\_\_

(2) \_\_\_\_\_

(3) \_\_\_\_\_

(4) \_\_\_\_\_

(5) \_\_\_\_\_

(6) \_\_\_\_\_

(7) \_\_\_\_\_

Hazards: (1) \_\_\_\_\_

(2) \_\_\_\_\_

(3) \_\_\_\_\_

(4) \_\_\_\_\_

(5) \_\_\_\_\_

(6) \_\_\_\_\_

(7) \_\_\_\_\_

Precautions: (1) \_\_\_\_\_

(2) \_\_\_\_\_

(3) \_\_\_\_\_

(4) \_\_\_\_\_

(5) \_\_\_\_\_

(6) \_\_\_\_\_

(7) \_\_\_\_\_

Signatures: \_\_\_\_\_

\_\_\_\_\_

\_\_\_\_\_

Date \_\_\_\_\_

- 1. Description of lifted object(s) \_\_\_\_\_  
\_\_\_\_\_
- 2. Weight of object to be lifted \_\_\_\_\_
- 3. How was the weight of the object obtained? \_\_\_\_\_  
\_\_\_\_\_
- 4. Crane Info.            Make \_\_\_\_\_  
                                  Model \_\_\_\_\_  
                                  Equipment Number \_\_\_\_\_  
                                  Serial Number \_\_\_\_\_

- 5. Total deductions for crane--jib, wire rope, block, ball, etc.....
  - 6. Total weight of all rigging (slings, shackles, bars, etc.) used in the lift.....
  - 7. Total lifted load. Determined by adding lines 2,5,6.....**
  - 8. What is the planned radius of the lift. (at the longest point).....
  - 9. What is the rated capacity of the crane you were using at the radius listed above?.....
  - 10. Divide line 7 by 9 for percent of load chart used. If over 75% of chart, a critical lift plan is necessary.....
- |  |   |
|--|---|
|  |   |
|  |   |
|  |   |
|  |   |
|  |   |
|  | % |

**All employees involved must sign off on the lines provided below.**

\_\_\_\_\_

\_\_\_\_\_

\_\_\_\_\_

Supt \_\_\_\_\_

**Note: Use the back of this page to write a lift specific Job Hazard Analysis.**

# LIFTING CRANE SAFETY TO NEW HEIGHTS

Date \_\_\_\_\_

## On the Spot Lift Plan Hazard Analysis

Operation: \_\_\_\_\_

Procedure: (1) \_\_\_\_\_

(2) \_\_\_\_\_

(3) \_\_\_\_\_

(4) \_\_\_\_\_

(5) \_\_\_\_\_

(6) \_\_\_\_\_

(7) \_\_\_\_\_

Hazards: (1) \_\_\_\_\_

(2) \_\_\_\_\_

(3) \_\_\_\_\_

(4) \_\_\_\_\_

(5) \_\_\_\_\_

(6) \_\_\_\_\_

(7) \_\_\_\_\_

Precautions: (1) \_\_\_\_\_

(2) \_\_\_\_\_

(3) \_\_\_\_\_

(4) \_\_\_\_\_

(5) \_\_\_\_\_

(6) \_\_\_\_\_

(7) \_\_\_\_\_

Signatures: \_\_\_\_\_

\_\_\_\_\_

\_\_\_\_\_

Date \_\_\_\_\_

- 1. Description of lifted object(s) \_\_\_\_\_  
\_\_\_\_\_
- 2. Weight of object to be lifted \_\_\_\_\_
- 3. How was the weight of the object obtained? \_\_\_\_\_  
\_\_\_\_\_
- 4. Crane Info.            Make \_\_\_\_\_  
                                  Model \_\_\_\_\_  
                                  Equipment Number \_\_\_\_\_  
                                  Serial Number \_\_\_\_\_

- 5. Total deductions for crane--jib, wire rope, block, ball, etc.....

--
- 6. Total weight of all rigging (slings, shackles, bars, etc.) used in the lift.....

--
- 7. **Total lifted load. Determined by adding lines 2,5,6.....**

--
- 8. What is the planned radius of the lift. (at the longest point).....

--
- 9. What is the rated capacity of the crane you were using at the radius listed above?.....

--
- 10. Divide line 7 by 9 for percent of load chart used. If over 75% of chart, a critical lift plan is necessary.....

--	--

 %

**All employees involved must sign off on the lines provided below.**

\_\_\_\_\_  
\_\_\_\_\_  
\_\_\_\_\_ Supt \_\_\_\_\_

**Note: Use the back of this page to write a lift specific Job Hazard Analysis.**

# LIFTING CRANE SAFETY TO NEW HEIGHTS

Date \_\_\_\_\_

## On the Spot Lift Plan Hazard Analysis

Operation: \_\_\_\_\_

Procedure: (1) \_\_\_\_\_

(2) \_\_\_\_\_

(3) \_\_\_\_\_

(4) \_\_\_\_\_

(5) \_\_\_\_\_

(6) \_\_\_\_\_

(7) \_\_\_\_\_

Hazards: (1) \_\_\_\_\_

(2) \_\_\_\_\_

(3) \_\_\_\_\_

(4) \_\_\_\_\_

(5) \_\_\_\_\_

(6) \_\_\_\_\_

(7) \_\_\_\_\_

Precautions: (1) \_\_\_\_\_

(2) \_\_\_\_\_

(3) \_\_\_\_\_

(4) \_\_\_\_\_

(5) \_\_\_\_\_

(6) \_\_\_\_\_

(7) \_\_\_\_\_

Signatures: \_\_\_\_\_

\_\_\_\_\_

\_\_\_\_\_

**Date** \_\_\_\_\_

1. Description of lifted object(s) \_\_\_\_\_  
\_\_\_\_\_
2. Weight of object to be lifted \_\_\_\_\_
3. How was the weight of the object obtained? \_\_\_\_\_  
\_\_\_\_\_
4. Crane Info.            Make \_\_\_\_\_  
                                  Model \_\_\_\_\_  
                                  Equipment Number \_\_\_\_\_  
                                  Serial Number \_\_\_\_\_

- |   |  |
|---|--|
| 5. Total deductions for crane--jib, wire rope, block, ball, etc.....  |  |
| 6. Total weight of all rigging (slings, shackles, bars, etc.) used in the lift.....                                 |  |
| <b>7. Total lifted load. Determined by adding lines 2,5,6.....</b>  |  |
| 8. What is the planned radius of the lift. (at the longest point).....  |  |
| 9. What is the rated capacity of the crane you were using at the radius listed above?.....                          |  |
| 10. Divide line 7 by 9 for percent of load chart used. If over 75% of chart, a critical lift plan is necessary..... |  |

**All employees involved must sign off on the lines provided below.**

\_\_\_\_\_  
\_\_\_\_\_  
\_\_\_\_\_ Supt \_\_\_\_\_

**Note: Use the back of this page to write a lift specific Job Hazard Analysis.**

# LIFTING CRANE SAFETY TO NEW HEIGHTS

Date \_\_\_\_\_

## On the Spot Lift Plan Hazard Analysis

Operation: \_\_\_\_\_

Procedure: (1) \_\_\_\_\_

(2) \_\_\_\_\_

(3) \_\_\_\_\_

(4) \_\_\_\_\_

(5) \_\_\_\_\_

(6) \_\_\_\_\_

(7) \_\_\_\_\_

Hazards: (1) \_\_\_\_\_

(2) \_\_\_\_\_

(3) \_\_\_\_\_

(4) \_\_\_\_\_

(5) \_\_\_\_\_

(6) \_\_\_\_\_

(7) \_\_\_\_\_

Precautions: (1) \_\_\_\_\_

(2) \_\_\_\_\_

(3) \_\_\_\_\_

(4) \_\_\_\_\_

(5) \_\_\_\_\_

(6) \_\_\_\_\_

(7) \_\_\_\_\_

Signatures: \_\_\_\_\_

\_\_\_\_\_

\_\_\_\_\_



# LIFTING CRANE SAFETY TO NEW HEIGHTS

Date \_\_\_\_\_

## On the Spot Lift Plan Hazard Analysis

Operation: \_\_\_\_\_

Procedure: (1) \_\_\_\_\_

(2) \_\_\_\_\_

(3) \_\_\_\_\_

(4) \_\_\_\_\_

(5) \_\_\_\_\_

(6) \_\_\_\_\_

(7) \_\_\_\_\_

Hazards: (1) \_\_\_\_\_

(2) \_\_\_\_\_

(3) \_\_\_\_\_

(4) \_\_\_\_\_

(5) \_\_\_\_\_

(6) \_\_\_\_\_

(7) \_\_\_\_\_

Precautions: (1) \_\_\_\_\_

(2) \_\_\_\_\_

(3) \_\_\_\_\_

(4) \_\_\_\_\_

(5) \_\_\_\_\_

(6) \_\_\_\_\_

(7) \_\_\_\_\_

Signatures: \_\_\_\_\_

\_\_\_\_\_

\_\_\_\_\_



# LIFTING CRANE SAFETY TO NEW HEIGHTS

Date \_\_\_\_\_

## On the Spot Lift Plan Hazard Analysis

Operation: \_\_\_\_\_

Procedure: (1) \_\_\_\_\_

(2) \_\_\_\_\_

(3) \_\_\_\_\_

(4) \_\_\_\_\_

(5) \_\_\_\_\_

(6) \_\_\_\_\_

(7) \_\_\_\_\_

Hazards: (1) \_\_\_\_\_

(2) \_\_\_\_\_

(3) \_\_\_\_\_

(4) \_\_\_\_\_

(5) \_\_\_\_\_

(6) \_\_\_\_\_

(7) \_\_\_\_\_

Precautions: (1) \_\_\_\_\_

(2) \_\_\_\_\_

(3) \_\_\_\_\_

(4) \_\_\_\_\_

(5) \_\_\_\_\_

(6) \_\_\_\_\_

(7) \_\_\_\_\_

Signatures: \_\_\_\_\_

\_\_\_\_\_

\_\_\_\_\_



# LIFTING CRANE SAFETY TO NEW HEIGHTS

Date \_\_\_\_\_

## On the Spot Lift Plan Hazard Analysis

Operation: \_\_\_\_\_

Procedure: (1) \_\_\_\_\_

(2) \_\_\_\_\_

(3) \_\_\_\_\_

(4) \_\_\_\_\_

(5) \_\_\_\_\_

(6) \_\_\_\_\_

(7) \_\_\_\_\_

Hazards: (1) \_\_\_\_\_

(2) \_\_\_\_\_

(3) \_\_\_\_\_

(4) \_\_\_\_\_

(5) \_\_\_\_\_

(6) \_\_\_\_\_

(7) \_\_\_\_\_

Precautions: (1) \_\_\_\_\_

(2) \_\_\_\_\_

(3) \_\_\_\_\_

(4) \_\_\_\_\_

(5) \_\_\_\_\_

(6) \_\_\_\_\_

(7) \_\_\_\_\_

Signatures: \_\_\_\_\_

\_\_\_\_\_

\_\_\_\_\_

**Date** \_\_\_\_\_

1. Description of lifted object(s) \_\_\_\_\_  
\_\_\_\_\_
2. Weight of object to be lifted \_\_\_\_\_
3. How was the weight of the object obtained? \_\_\_\_\_  
\_\_\_\_\_
4. Crane Info.            Make \_\_\_\_\_  
                                  Model \_\_\_\_\_  
                                  Equipment Number \_\_\_\_\_  
                                  Serial Number \_\_\_\_\_

- |   |   |
|---|---|
| 5. Total deductions for crane--jib, wire rope, block, ball, etc.....  |   |
| 6. Total weight of all rigging (slings, shackles, bars, etc.) used in the lift.....                                 |   |
| <b>7. Total lifted load. Determined by adding lines 2,5,6.....</b>  |   |
| 8. What is the planned radius of the lift. (at the longest point).....  |   |
| 9. What is the rated capacity of the crane you were using at the radius listed above?.....                          |   |
| 10. Divide line 7 by 9 for percent of load chart used. If over 75% of chart, a critical lift plan is necessary..... | % |

**All employees involved must sign off on the lines provided below.**

\_\_\_\_\_  
\_\_\_\_\_  
\_\_\_\_\_ Supt \_\_\_\_\_

**Note: Use the back of this page to write a lift specific Job Hazard Analysis.**

# LIFTING CRANE SAFETY TO NEW HEIGHTS

Date \_\_\_\_\_

## On the Spot Lift Plan Hazard Analysis

Operation: \_\_\_\_\_

Procedure: (1) \_\_\_\_\_

(2) \_\_\_\_\_

(3) \_\_\_\_\_

(4) \_\_\_\_\_

(5) \_\_\_\_\_

(6) \_\_\_\_\_

(7) \_\_\_\_\_

Hazards: (1) \_\_\_\_\_

(2) \_\_\_\_\_

(3) \_\_\_\_\_

(4) \_\_\_\_\_

(5) \_\_\_\_\_

(6) \_\_\_\_\_

(7) \_\_\_\_\_

Precautions: (1) \_\_\_\_\_

(2) \_\_\_\_\_

(3) \_\_\_\_\_

(4) \_\_\_\_\_

(5) \_\_\_\_\_

(6) \_\_\_\_\_

(7) \_\_\_\_\_

Signatures: \_\_\_\_\_

\_\_\_\_\_

\_\_\_\_\_

# LIFTING CRANE SAFETY TO NEW HEIGHTS

Date \_\_\_\_\_

## On the Spot Lift Plan Hazard Analysis

Operation: \_\_\_\_\_

Procedure: (1) \_\_\_\_\_

(2) \_\_\_\_\_

(3) \_\_\_\_\_

(4) \_\_\_\_\_

(5) \_\_\_\_\_

(6) \_\_\_\_\_

(7) \_\_\_\_\_

Hazards: (1) \_\_\_\_\_

(2) \_\_\_\_\_

(3) \_\_\_\_\_

(4) \_\_\_\_\_

(5) \_\_\_\_\_

(6) \_\_\_\_\_

(7) \_\_\_\_\_

Precautions: (1) \_\_\_\_\_

(2) \_\_\_\_\_

(3) \_\_\_\_\_

(4) \_\_\_\_\_

(5) \_\_\_\_\_

(6) \_\_\_\_\_

(7) \_\_\_\_\_

Signatures: \_\_\_\_\_

\_\_\_\_\_

\_\_\_\_\_

# LIFTING CRANE SAFETY TO NEW HEIGHTS

Date \_\_\_\_\_

## On the Spot Lift Plan Hazard Analysis

Operation: \_\_\_\_\_

Procedure: (1) \_\_\_\_\_

(2) \_\_\_\_\_

(3) \_\_\_\_\_

(4) \_\_\_\_\_

(5) \_\_\_\_\_

(6) \_\_\_\_\_

(7) \_\_\_\_\_

Hazards: (1) \_\_\_\_\_

(2) \_\_\_\_\_

(3) \_\_\_\_\_

(4) \_\_\_\_\_

(5) \_\_\_\_\_

(6) \_\_\_\_\_

(7) \_\_\_\_\_

Precautions: (1) \_\_\_\_\_

(2) \_\_\_\_\_

(3) \_\_\_\_\_

(4) \_\_\_\_\_

(5) \_\_\_\_\_

(6) \_\_\_\_\_

(7) \_\_\_\_\_

Signatures: \_\_\_\_\_

\_\_\_\_\_

\_\_\_\_\_

**Date** \_\_\_\_\_

1. Description of lifted object(s) \_\_\_\_\_  
\_\_\_\_\_
2. Weight of object to be lifted \_\_\_\_\_
3. How was the weight of the object obtained? \_\_\_\_\_  
\_\_\_\_\_
4. Crane Info.            Make \_\_\_\_\_  
                                  Model \_\_\_\_\_  
                                  Equipment Number \_\_\_\_\_  
                                  Serial Number \_\_\_\_\_

- |   |   |
|---|---|
| 5. Total deductions for crane--jib, wire rope, block, ball, etc.....  |   |
| 6. Total weight of all rigging (slings, shackles, bars, etc.) used in the lift.....                                 |   |
| <b>7. Total lifted load. Determined by adding lines 2,5,6.....</b>  |   |
| 8. What is the planned radius of the lift. (at the longest point).....  |   |
| 9. What is the rated capacity of the crane you were using at the radius listed above?.....                          |   |
| 10. Divide line 7 by 9 for percent of load chart used. If over 75% of chart, a critical lift plan is necessary..... | % |

**All employees involved must sign off on the lines provided below.**

\_\_\_\_\_  
\_\_\_\_\_  
\_\_\_\_\_ Supt \_\_\_\_\_

**Note: Use the back of this page to write a lift specific Job Hazard Analysis.**

# LIFTING CRANE SAFETY TO NEW HEIGHTS

Date \_\_\_\_\_

## On the Spot Lift Plan Hazard Analysis

Operation: \_\_\_\_\_

Procedure: (1) \_\_\_\_\_

(2) \_\_\_\_\_

(3) \_\_\_\_\_

(4) \_\_\_\_\_

(5) \_\_\_\_\_

(6) \_\_\_\_\_

(7) \_\_\_\_\_

Hazards: (1) \_\_\_\_\_

(2) \_\_\_\_\_

(3) \_\_\_\_\_

(4) \_\_\_\_\_

(5) \_\_\_\_\_

(6) \_\_\_\_\_

(7) \_\_\_\_\_

Precautions: (1) \_\_\_\_\_

(2) \_\_\_\_\_

(3) \_\_\_\_\_

(4) \_\_\_\_\_

(5) \_\_\_\_\_

(6) \_\_\_\_\_

(7) \_\_\_\_\_

Signatures: \_\_\_\_\_

\_\_\_\_\_

\_\_\_\_\_



# LIFTING CRANE SAFETY TO NEW HEIGHTS

Date \_\_\_\_\_

## On the Spot Lift Plan Hazard Analysis

Operation: \_\_\_\_\_

Procedure: (1) \_\_\_\_\_

(2) \_\_\_\_\_

(3) \_\_\_\_\_

(4) \_\_\_\_\_

(5) \_\_\_\_\_

(6) \_\_\_\_\_

(7) \_\_\_\_\_

Hazards: (1) \_\_\_\_\_

(2) \_\_\_\_\_

(3) \_\_\_\_\_

(4) \_\_\_\_\_

(5) \_\_\_\_\_

(6) \_\_\_\_\_

(7) \_\_\_\_\_

Precautions: (1) \_\_\_\_\_

(2) \_\_\_\_\_

(3) \_\_\_\_\_

(4) \_\_\_\_\_

(5) \_\_\_\_\_

(6) \_\_\_\_\_

(7) \_\_\_\_\_

Signatures: \_\_\_\_\_

\_\_\_\_\_

\_\_\_\_\_



# LIFTING CRANE SAFETY TO NEW HEIGHTS

Date \_\_\_\_\_

## On the Spot Lift Plan Hazard Analysis

Operation: \_\_\_\_\_

Procedure: (1) \_\_\_\_\_

(2) \_\_\_\_\_

(3) \_\_\_\_\_

(4) \_\_\_\_\_

(5) \_\_\_\_\_

(6) \_\_\_\_\_

(7) \_\_\_\_\_

Hazards: (1) \_\_\_\_\_

(2) \_\_\_\_\_

(3) \_\_\_\_\_

(4) \_\_\_\_\_

(5) \_\_\_\_\_

(6) \_\_\_\_\_

(7) \_\_\_\_\_

Precautions: (1) \_\_\_\_\_

(2) \_\_\_\_\_

(3) \_\_\_\_\_

(4) \_\_\_\_\_

(5) \_\_\_\_\_

(6) \_\_\_\_\_

(7) \_\_\_\_\_

Signatures: \_\_\_\_\_

\_\_\_\_\_

\_\_\_\_\_



# LIFTING CRANE SAFETY TO NEW HEIGHTS

Date \_\_\_\_\_

## On the Spot Lift Plan Hazard Analysis

Operation: \_\_\_\_\_

Procedure: (1) \_\_\_\_\_

(2) \_\_\_\_\_

(3) \_\_\_\_\_

(4) \_\_\_\_\_

(5) \_\_\_\_\_

(6) \_\_\_\_\_

(7) \_\_\_\_\_

Hazards: (1) \_\_\_\_\_

(2) \_\_\_\_\_

(3) \_\_\_\_\_

(4) \_\_\_\_\_

(5) \_\_\_\_\_

(6) \_\_\_\_\_

(7) \_\_\_\_\_

Precautions: (1) \_\_\_\_\_

(2) \_\_\_\_\_

(3) \_\_\_\_\_

(4) \_\_\_\_\_

(5) \_\_\_\_\_

(6) \_\_\_\_\_

(7) \_\_\_\_\_

Signatures: \_\_\_\_\_

\_\_\_\_\_

\_\_\_\_\_

**Date** \_\_\_\_\_

1. Description of lifted object(s) \_\_\_\_\_  
\_\_\_\_\_
2. Weight of object to be lifted \_\_\_\_\_
3. How was the weight of the object obtained? \_\_\_\_\_  
\_\_\_\_\_
4. Crane Info.            Make \_\_\_\_\_  
                                  Model \_\_\_\_\_  
                                  Equipment Number \_\_\_\_\_  
                                  Serial Number \_\_\_\_\_

- |   |  |
|---|--|
| 5. Total deductions for crane--jib, wire rope, block, ball, etc.....  |  |
| 6. Total weight of all rigging (slings, shackles, bars, etc.) used in the lift.....                                 |  |
| <b>7. Total lifted load. Determined by adding lines 2,5,6.....</b>  |  |
| 8. What is the planned radius of the lift. (at the longest point).....  |  |
| 9. What is the rated capacity of the crane you were using at the radius listed above?.....                          |  |
| 10. Divide line 7 by 9 for percent of load chart used. If over 75% of chart, a critical lift plan is necessary..... |  |

**All employees involved must sign off on the lines provided below.**

\_\_\_\_\_  
\_\_\_\_\_  
\_\_\_\_\_ Supt \_\_\_\_\_

**Note: Use the back of this page to write a lift specific Job Hazard Analysis.**

# LIFTING CRANE SAFETY TO NEW HEIGHTS

Date \_\_\_\_\_

## On the Spot Lift Plan Hazard Analysis

Operation: \_\_\_\_\_

Procedure: (1) \_\_\_\_\_

(2) \_\_\_\_\_

(3) \_\_\_\_\_

(4) \_\_\_\_\_

(5) \_\_\_\_\_

(6) \_\_\_\_\_

(7) \_\_\_\_\_

Hazards: (1) \_\_\_\_\_

(2) \_\_\_\_\_

(3) \_\_\_\_\_

(4) \_\_\_\_\_

(5) \_\_\_\_\_

(6) \_\_\_\_\_

(7) \_\_\_\_\_

Precautions: (1) \_\_\_\_\_

(2) \_\_\_\_\_

(3) \_\_\_\_\_

(4) \_\_\_\_\_

(5) \_\_\_\_\_

(6) \_\_\_\_\_

(7) \_\_\_\_\_

Signatures: \_\_\_\_\_

\_\_\_\_\_

\_\_\_\_\_

Date \_\_\_\_\_

- 1. Description of lifted object(s) \_\_\_\_\_  
\_\_\_\_\_
- 2. Weight of object to be lifted \_\_\_\_\_
- 3. How was the weight of the object obtained? \_\_\_\_\_  
\_\_\_\_\_
- 4. Crane Info.            Make \_\_\_\_\_  
                                  Model \_\_\_\_\_  
                                  Equipment Number \_\_\_\_\_  
                                  Serial Number \_\_\_\_\_

- 5. Total deductions for crane--jib, wire rope, block, ball, etc.....
  - 6. Total weight of all rigging (slings, shackles, bars, etc.) used in the lift.....
  - 7. Total lifted load. Determined by adding lines 2,5,6.....**
  - 8. What is the planned radius of the lift. (at the longest point).....
  - 9. What is the rated capacity of the crane you were using at the radius listed above?.....
  - 10. Divide line 7 by 9 for percent of load chart used. If over 75% of chart, a critical lift plan is necessary.....
- |  |   |
|--|---|
|  |   |
|  |   |
|  |   |
|  |   |
|  |   |
|  | % |

**All employees involved must sign off on the lines provided below.**

\_\_\_\_\_  
\_\_\_\_\_  
\_\_\_\_\_ Supt \_\_\_\_\_

**Note: Use the back of this page to write a lift specific Job Hazard Analysis.**

# LIFTING CRANE SAFETY TO NEW HEIGHTS

Date \_\_\_\_\_

## On the Spot Lift Plan Hazard Analysis

Operation: \_\_\_\_\_

Procedure: (1) \_\_\_\_\_

(2) \_\_\_\_\_

(3) \_\_\_\_\_

(4) \_\_\_\_\_

(5) \_\_\_\_\_

(6) \_\_\_\_\_

(7) \_\_\_\_\_

Hazards: (1) \_\_\_\_\_

(2) \_\_\_\_\_

(3) \_\_\_\_\_

(4) \_\_\_\_\_

(5) \_\_\_\_\_

(6) \_\_\_\_\_

(7) \_\_\_\_\_

Precautions: (1) \_\_\_\_\_

(2) \_\_\_\_\_

(3) \_\_\_\_\_

(4) \_\_\_\_\_

(5) \_\_\_\_\_

(6) \_\_\_\_\_

(7) \_\_\_\_\_

Signatures: \_\_\_\_\_

\_\_\_\_\_

\_\_\_\_\_

**Date** \_\_\_\_\_

1. Description of lifted object(s) \_\_\_\_\_  
\_\_\_\_\_
2. Weight of object to be lifted \_\_\_\_\_
3. How was the weight of the object obtained? \_\_\_\_\_  
\_\_\_\_\_
4. Crane Info.            Make \_\_\_\_\_  
                                  Model \_\_\_\_\_  
                                  Equipment Number \_\_\_\_\_  
                                  Serial Number \_\_\_\_\_

- |   |  |
|---|--|
| 5. Total deductions for crane--jib, wire rope, block, ball, etc.....  |  |
| 6. Total weight of all rigging (slings, shackles, bars, etc.) used in the lift.....                                 |  |
| <b>7. Total lifted load. Determined by adding lines 2,5,6.....</b>  |  |
| 8. What is the planned radius of the lift. (at the longest point).....  |  |
| 9. What is the rated capacity of the crane you were using at the radius listed above?.....                          |  |
| 10. Divide line 7 by 9 for percent of load chart used. If over 75% of chart, a critical lift plan is necessary..... |  |

**All employees involved must sign off on the lines provided below.**

\_\_\_\_\_  
\_\_\_\_\_  
\_\_\_\_\_ Supt \_\_\_\_\_

**Note: Use the back of this page to write a lift specific Job Hazard Analysis.**

# LIFTING CRANE SAFETY TO NEW HEIGHTS

Date \_\_\_\_\_

## On the Spot Lift Plan Hazard Analysis

Operation: \_\_\_\_\_

Procedure: (1) \_\_\_\_\_

(2) \_\_\_\_\_

(3) \_\_\_\_\_

(4) \_\_\_\_\_

(5) \_\_\_\_\_

(6) \_\_\_\_\_

(7) \_\_\_\_\_

Hazards: (1) \_\_\_\_\_

(2) \_\_\_\_\_

(3) \_\_\_\_\_

(4) \_\_\_\_\_

(5) \_\_\_\_\_

(6) \_\_\_\_\_

(7) \_\_\_\_\_

Precautions: (1) \_\_\_\_\_

(2) \_\_\_\_\_

(3) \_\_\_\_\_

(4) \_\_\_\_\_

(5) \_\_\_\_\_

(6) \_\_\_\_\_

(7) \_\_\_\_\_

Signatures: \_\_\_\_\_

\_\_\_\_\_

\_\_\_\_\_

**Date** \_\_\_\_\_

1. Description of lifted object(s) \_\_\_\_\_  
\_\_\_\_\_
2. Weight of object to be lifted \_\_\_\_\_
3. How was the weight of the object obtained? \_\_\_\_\_  
\_\_\_\_\_
4. Crane Info.            Make \_\_\_\_\_  
                                  Model \_\_\_\_\_  
                                  Equipment Number \_\_\_\_\_  
                                  Serial Number \_\_\_\_\_

- |   |   |
|---|---|
| 5. Total deductions for crane--jib, wire rope, block, ball, etc.....  |   |
| 6. Total weight of all rigging (slings, shackles, bars, etc.) used in the lift.....                                 |   |
| <b>7. Total lifted load. Determined by adding lines 2,5,6.....</b>  |   |
| 8. What is the planned radius of the lift. (at the longest point).....  |   |
| 9. What is the rated capacity of the crane you were using at the radius listed above?.....                          |   |
| 10. Divide line 7 by 9 for percent of load chart used. If over 75% of chart, a critical lift plan is necessary..... | % |

**All employees involved must sign off on the lines provided below.**

\_\_\_\_\_  
\_\_\_\_\_  
\_\_\_\_\_ Supt \_\_\_\_\_

**Note: Use the back of this page to write a lift specific Job Hazard Analysis.**

# LIFTING CRANE SAFETY TO NEW HEIGHTS

Date \_\_\_\_\_

## On the Spot Lift Plan Hazard Analysis

Operation: \_\_\_\_\_

Procedure: (1) \_\_\_\_\_

(2) \_\_\_\_\_

(3) \_\_\_\_\_

(4) \_\_\_\_\_

(5) \_\_\_\_\_

(6) \_\_\_\_\_

(7) \_\_\_\_\_

Hazards: (1) \_\_\_\_\_

(2) \_\_\_\_\_

(3) \_\_\_\_\_

(4) \_\_\_\_\_

(5) \_\_\_\_\_

(6) \_\_\_\_\_

(7) \_\_\_\_\_

Precautions: (1) \_\_\_\_\_

(2) \_\_\_\_\_

(3) \_\_\_\_\_

(4) \_\_\_\_\_

(5) \_\_\_\_\_

(6) \_\_\_\_\_

(7) \_\_\_\_\_

Signatures: \_\_\_\_\_

\_\_\_\_\_

\_\_\_\_\_

**Date** \_\_\_\_\_

1. Description of lifted object(s) \_\_\_\_\_  
\_\_\_\_\_
2. Weight of object to be lifted \_\_\_\_\_
3. How was the weight of the object obtained? \_\_\_\_\_  
\_\_\_\_\_
4. Crane Info.            Make \_\_\_\_\_  
                                  Model \_\_\_\_\_  
                                  Equipment Number \_\_\_\_\_  
                                  Serial Number \_\_\_\_\_

- |   |   |
|---|---|
| 5. Total deductions for crane--jib, wire rope, block, ball, etc.....  |   |
| 6. Total weight of all rigging (slings, shackles, bars, etc.) used in the lift.....                                 |   |
| <b>7. Total lifted load. Determined by adding lines 2,5,6.....</b>  |   |
| 8. What is the planned radius of the lift. (at the longest point).....  |   |
| 9. What is the rated capacity of the crane you were using at the radius listed above?.....                          |   |
| 10. Divide line 7 by 9 for percent of load chart used. If over 75% of chart, a critical lift plan is necessary..... | % |

**All employees involved must sign off on the lines provided below.**

\_\_\_\_\_  
\_\_\_\_\_  
\_\_\_\_\_ Supt \_\_\_\_\_

**Note: Use the back of this page to write a lift specific Job Hazard Analysis.**

# LIFTING CRANE SAFETY TO NEW HEIGHTS

Date \_\_\_\_\_

## On the Spot Lift Plan Hazard Analysis

Operation: \_\_\_\_\_

Procedure: (1) \_\_\_\_\_

(2) \_\_\_\_\_

(3) \_\_\_\_\_

(4) \_\_\_\_\_

(5) \_\_\_\_\_

(6) \_\_\_\_\_

(7) \_\_\_\_\_

Hazards: (1) \_\_\_\_\_

(2) \_\_\_\_\_

(3) \_\_\_\_\_

(4) \_\_\_\_\_

(5) \_\_\_\_\_

(6) \_\_\_\_\_

(7) \_\_\_\_\_

Precautions: (1) \_\_\_\_\_

(2) \_\_\_\_\_

(3) \_\_\_\_\_

(4) \_\_\_\_\_

(5) \_\_\_\_\_

(6) \_\_\_\_\_

(7) \_\_\_\_\_

Signatures: \_\_\_\_\_

\_\_\_\_\_

\_\_\_\_\_

**Date** \_\_\_\_\_

1. Description of lifted object(s) \_\_\_\_\_  
\_\_\_\_\_
2. Weight of object to be lifted \_\_\_\_\_
3. How was the weight of the object obtained? \_\_\_\_\_  
\_\_\_\_\_
4. Crane Info.            Make \_\_\_\_\_  
                                  Model \_\_\_\_\_  
                                  Equipment Number \_\_\_\_\_  
                                  Serial Number \_\_\_\_\_

- |   |   |
|---|---|
| 5. Total deductions for crane--jib, wire rope, block, ball, etc.....  |   |
| 6. Total weight of all rigging (slings, shackles, bars, etc.) used in the lift.....                                 |   |
| <b>7. Total lifted load. Determined by adding lines 2,5,6.....</b>  |   |
| 8. What is the planned radius of the lift. (at the longest point).....  |   |
| 9. What is the rated capacity of the crane you were using at the radius listed above?.....                          |   |
| 10. Divide line 7 by 9 for percent of load chart used. If over 75% of chart, a critical lift plan is necessary..... | % |

**All employees involved must sign off on the lines provided below.**

\_\_\_\_\_  
\_\_\_\_\_  
\_\_\_\_\_ Supt \_\_\_\_\_

**Note: Use the back of this page to write a lift specific Job Hazard Analysis.**

# LIFTING CRANE SAFETY TO NEW HEIGHTS

Date \_\_\_\_\_

## On the Spot Lift Plan Hazard Analysis

Operation: \_\_\_\_\_

Procedure: (1) \_\_\_\_\_

(2) \_\_\_\_\_

(3) \_\_\_\_\_

(4) \_\_\_\_\_

(5) \_\_\_\_\_

(6) \_\_\_\_\_

(7) \_\_\_\_\_

Hazards: (1) \_\_\_\_\_

(2) \_\_\_\_\_

(3) \_\_\_\_\_

(4) \_\_\_\_\_

(5) \_\_\_\_\_

(6) \_\_\_\_\_

(7) \_\_\_\_\_

Precautions: (1) \_\_\_\_\_

(2) \_\_\_\_\_

(3) \_\_\_\_\_

(4) \_\_\_\_\_

(5) \_\_\_\_\_

(6) \_\_\_\_\_

(7) \_\_\_\_\_

Signatures: \_\_\_\_\_

\_\_\_\_\_

\_\_\_\_\_

**Date** \_\_\_\_\_

1. Description of lifted object(s) \_\_\_\_\_  
\_\_\_\_\_
2. Weight of object to be lifted \_\_\_\_\_
3. How was the weight of the object obtained? \_\_\_\_\_  
\_\_\_\_\_
4. Crane Info.            Make \_\_\_\_\_  
                                  Model \_\_\_\_\_  
                                  Equipment Number \_\_\_\_\_  
                                  Serial Number \_\_\_\_\_

- |   |   |
|---|---|
| 5. Total deductions for crane--jib, wire rope, block, ball, etc.....  |   |
| 6. Total weight of all rigging (slings, shackles, bars, etc.) used in the lift.....                                 |   |
| <b>7. Total lifted load. Determined by adding lines 2,5,6.....</b>  |   |
| 8. What is the planned radius of the lift. (at the longest point).....  |   |
| 9. What is the rated capacity of the crane you were using at the radius listed above?.....                          |   |
| 10. Divide line 7 by 9 for percent of load chart used. If over 75% of chart, a critical lift plan is necessary..... | % |

**All employees involved must sign off on the lines provided below.**

\_\_\_\_\_  
\_\_\_\_\_  
\_\_\_\_\_ Supt \_\_\_\_\_

**Note: Use the back of this page to write a lift specific Job Hazard Analysis.**

# LIFTING CRANE SAFETY TO NEW HEIGHTS

Date \_\_\_\_\_

## On the Spot Lift Plan Hazard Analysis

Operation: \_\_\_\_\_

Procedure: (1) \_\_\_\_\_

(2) \_\_\_\_\_

(3) \_\_\_\_\_

(4) \_\_\_\_\_

(5) \_\_\_\_\_

(6) \_\_\_\_\_

(7) \_\_\_\_\_

Hazards: (1) \_\_\_\_\_

(2) \_\_\_\_\_

(3) \_\_\_\_\_

(4) \_\_\_\_\_

(5) \_\_\_\_\_

(6) \_\_\_\_\_

(7) \_\_\_\_\_

Precautions: (1) \_\_\_\_\_

(2) \_\_\_\_\_

(3) \_\_\_\_\_

(4) \_\_\_\_\_

(5) \_\_\_\_\_

(6) \_\_\_\_\_

(7) \_\_\_\_\_

Signatures: \_\_\_\_\_

\_\_\_\_\_

\_\_\_\_\_

**Date** \_\_\_\_\_

1. Description of lifted object(s) \_\_\_\_\_  
\_\_\_\_\_
2. Weight of object to be lifted \_\_\_\_\_
3. How was the weight of the object obtained? \_\_\_\_\_  
\_\_\_\_\_
4. Crane Info.            Make \_\_\_\_\_  
                                  Model \_\_\_\_\_  
                                  Equipment Number \_\_\_\_\_  
                                  Serial Number \_\_\_\_\_

- |   |   |
|---|---|
| 5. Total deductions for crane--jib, wire rope, block, ball, etc.....  |   |
| 6. Total weight of all rigging (slings, shackles, bars, etc.) used in the lift.....                                 |   |
| <b>7. Total lifted load. Determined by adding lines 2,5,6.....</b>  |   |
| 8. What is the planned radius of the lift. (at the longest point).....  |   |
| 9. What is the rated capacity of the crane you were using at the radius listed above?.....                          |   |
| 10. Divide line 7 by 9 for percent of load chart used. If over 75% of chart, a critical lift plan is necessary..... | % |

**All employees involved must sign off on the lines provided below.**

	Supt

**Note: Use the back of this page to write a lift specific Job Hazard Analysis.**

# LIFTING CRANE SAFETY TO NEW HEIGHTS

Date \_\_\_\_\_

## On the Spot Lift Plan Hazard Analysis

Operation: \_\_\_\_\_

Procedure: (1) \_\_\_\_\_

(2) \_\_\_\_\_

(3) \_\_\_\_\_

(4) \_\_\_\_\_

(5) \_\_\_\_\_

(6) \_\_\_\_\_

(7) \_\_\_\_\_

Hazards: (1) \_\_\_\_\_

(2) \_\_\_\_\_

(3) \_\_\_\_\_

(4) \_\_\_\_\_

(5) \_\_\_\_\_

(6) \_\_\_\_\_

(7) \_\_\_\_\_

Precautions: (1) \_\_\_\_\_

(2) \_\_\_\_\_

(3) \_\_\_\_\_

(4) \_\_\_\_\_

(5) \_\_\_\_\_

(6) \_\_\_\_\_

(7) \_\_\_\_\_

Signatures: \_\_\_\_\_

\_\_\_\_\_

\_\_\_\_\_

**Date** \_\_\_\_\_

1. Description of lifted object(s) \_\_\_\_\_  
\_\_\_\_\_
2. Weight of object to be lifted \_\_\_\_\_
3. How was the weight of the object obtained? \_\_\_\_\_  
\_\_\_\_\_
4. Crane Info.            Make \_\_\_\_\_  
                                  Model \_\_\_\_\_  
                                  Equipment Number \_\_\_\_\_  
                                  Serial Number \_\_\_\_\_

- |   |  |
|---|--|
| 5. Total deductions for crane--jib, wire rope, block, ball, etc.....  |  |
| 6. Total weight of all rigging (slings, shackles, bars, etc.) used in the lift.....                                 |  |
| <b>7. Total lifted load. Determined by adding lines 2,5,6.....</b>  |  |
| 8. What is the planned radius of the lift. (at the longest point).....  |  |
| 9. What is the rated capacity of the crane you were using at the radius listed above?.....                          |  |
| 10. Divide line 7 by 9 for percent of load chart used. If over 75% of chart, a critical lift plan is necessary..... |  |

**All employees involved must sign off on the lines provided below.**

\_\_\_\_\_  
\_\_\_\_\_  
\_\_\_\_\_ Supt \_\_\_\_\_

**Note: Use the back of this page to write a lift specific Job Hazard Analysis.**

# LIFTING CRANE SAFETY TO NEW HEIGHTS

Date \_\_\_\_\_

## On the Spot Lift Plan Hazard Analysis

Operation: \_\_\_\_\_

Procedure: (1) \_\_\_\_\_

(2) \_\_\_\_\_

(3) \_\_\_\_\_

(4) \_\_\_\_\_

(5) \_\_\_\_\_

(6) \_\_\_\_\_

(7) \_\_\_\_\_

Hazards: (1) \_\_\_\_\_

(2) \_\_\_\_\_

(3) \_\_\_\_\_

(4) \_\_\_\_\_

(5) \_\_\_\_\_

(6) \_\_\_\_\_

(7) \_\_\_\_\_

Precautions: (1) \_\_\_\_\_

(2) \_\_\_\_\_

(3) \_\_\_\_\_

(4) \_\_\_\_\_

(5) \_\_\_\_\_

(6) \_\_\_\_\_

(7) \_\_\_\_\_

Signatures: \_\_\_\_\_

\_\_\_\_\_

\_\_\_\_\_

**Date** \_\_\_\_\_

1. Description of lifted object(s) \_\_\_\_\_  
\_\_\_\_\_
2. Weight of object to be lifted \_\_\_\_\_
3. How was the weight of the object obtained? \_\_\_\_\_  
\_\_\_\_\_
4. Crane Info.            Make \_\_\_\_\_  
                                  Model \_\_\_\_\_  
                                  Equipment Number \_\_\_\_\_  
                                  Serial Number \_\_\_\_\_

- |   |   |
|---|---|
| 5. Total deductions for crane--jib, wire rope, block, ball, etc.....  |   |
| 6. Total weight of all rigging (slings, shackles, bars, etc.) used in the lift.....                                 |   |
| <b>7. Total lifted load. Determined by adding lines 2,5,6.....</b>  |   |
| 8. What is the planned radius of the lift. (at the longest point).....  |   |
| 9. What is the rated capacity of the crane you were using at the radius listed above?.....                          |   |
| 10. Divide line 7 by 9 for percent of load chart used. If over 75% of chart, a critical lift plan is necessary..... | % |

**All employees involved must sign off on the lines provided below.**

\_\_\_\_\_  
\_\_\_\_\_  
\_\_\_\_\_ Supt \_\_\_\_\_

**Note: Use the back of this page to write a lift specific Job Hazard Analysis.**

LIFTING CRANE SAFETY TO NEW HEIGHTS

Date \_\_\_\_\_

On the Spot Lift Plan  
Hazard Analysis

Operation: \_\_\_\_\_

Procedure: (1) \_\_\_\_\_

(2) \_\_\_\_\_

(3) \_\_\_\_\_

(4) \_\_\_\_\_

(5) \_\_\_\_\_

(6) \_\_\_\_\_

(7) \_\_\_\_\_

Hazards: (1) \_\_\_\_\_

(2) \_\_\_\_\_

(3) \_\_\_\_\_

(4) \_\_\_\_\_

(5) \_\_\_\_\_

(6) \_\_\_\_\_

(7) \_\_\_\_\_

Precautions: (1) \_\_\_\_\_

(2) \_\_\_\_\_

(3) \_\_\_\_\_

(4) \_\_\_\_\_

(5) \_\_\_\_\_

(6) \_\_\_\_\_

(7) \_\_\_\_\_

Signatures: \_\_\_\_\_

\_\_\_\_\_

\_\_\_\_\_

**Date** \_\_\_\_\_

1. Description of lifted object(s) \_\_\_\_\_  
\_\_\_\_\_
2. Weight of object to be lifted \_\_\_\_\_
3. How was the weight of the object obtained? \_\_\_\_\_  
\_\_\_\_\_
4. Crane Info.            Make \_\_\_\_\_  
                                  Model \_\_\_\_\_  
                                  Equipment Number \_\_\_\_\_  
                                  Serial Number \_\_\_\_\_

- |   |  |
|---|--|
| 5. Total deductions for crane--jib, wire rope, block, ball, etc.....  |  |
| 6. Total weight of all rigging (slings, shackles, bars, etc.) used in the lift.....                                 |  |
| <b>7. Total lifted load. Determined by adding lines 2,5,6.....</b>  |  |
| 8. What is the planned radius of the lift. (at the longest point).....  |  |
| 9. What is the rated capacity of the crane you were using at the radius listed above?.....                          |  |
| 10. Divide line 7 by 9 for percent of load chart used. If over 75% of chart, a critical lift plan is necessary..... |  |

**All employees involved must sign off on the lines provided below.**

\_\_\_\_\_  
\_\_\_\_\_  
\_\_\_\_\_ Supt \_\_\_\_\_

**Note: Use the back of this page to write a lift specific Job Hazard Analysis.**

# LIFTING CRANE SAFETY TO NEW HEIGHTS

Date \_\_\_\_\_

## On the Spot Lift Plan Hazard Analysis

Operation: \_\_\_\_\_

Procedure: (1) \_\_\_\_\_

(2) \_\_\_\_\_

(3) \_\_\_\_\_

(4) \_\_\_\_\_

(5) \_\_\_\_\_

(6) \_\_\_\_\_

(7) \_\_\_\_\_

Hazards: (1) \_\_\_\_\_

(2) \_\_\_\_\_

(3) \_\_\_\_\_

(4) \_\_\_\_\_

(5) \_\_\_\_\_

(6) \_\_\_\_\_

(7) \_\_\_\_\_

Precautions: (1) \_\_\_\_\_

(2) \_\_\_\_\_

(3) \_\_\_\_\_

(4) \_\_\_\_\_

(5) \_\_\_\_\_

(6) \_\_\_\_\_

(7) \_\_\_\_\_

Signatures: \_\_\_\_\_

\_\_\_\_\_

\_\_\_\_\_

**Date** \_\_\_\_\_

1. Description of lifted object(s) \_\_\_\_\_  
\_\_\_\_\_
2. Weight of object to be lifted \_\_\_\_\_
3. How was the weight of the object obtained? \_\_\_\_\_  
\_\_\_\_\_
4. Crane Info.            Make \_\_\_\_\_  
                                  Model \_\_\_\_\_  
                                  Equipment Number \_\_\_\_\_  
                                  Serial Number \_\_\_\_\_

- |   |  |
|---|--|
| 5. Total deductions for crane--jib, wire rope, block, ball, etc.....  |  |
| 6. Total weight of all rigging (slings, shackles, bars, etc.) used in the lift.....                                 |  |
| <b>7. Total lifted load. Determined by adding lines 2,5,6.....</b>  |  |
| 8. What is the planned radius of the lift. (at the longest point).....  |  |
| 9. What is the rated capacity of the crane you were using at the radius listed above?.....                          |  |
| 10. Divide line 7 by 9 for percent of load chart used. If over 75% of chart, a critical lift plan is necessary..... |  |

**All employees involved must sign off on the lines provided below.**

\_\_\_\_\_  
\_\_\_\_\_  
\_\_\_\_\_ Supt \_\_\_\_\_

**Note: Use the back of this page to write a lift specific Job Hazard Analysis.**

# LIFTING CRANE SAFETY TO NEW HEIGHTS

Date \_\_\_\_\_

## On the Spot Lift Plan Hazard Analysis

Operation: \_\_\_\_\_

Procedure: (1) \_\_\_\_\_

(2) \_\_\_\_\_

(3) \_\_\_\_\_

(4) \_\_\_\_\_

(5) \_\_\_\_\_

(6) \_\_\_\_\_

(7) \_\_\_\_\_

Hazards: (1) \_\_\_\_\_

(2) \_\_\_\_\_

(3) \_\_\_\_\_

(4) \_\_\_\_\_

(5) \_\_\_\_\_

(6) \_\_\_\_\_

(7) \_\_\_\_\_

Precautions: (1) \_\_\_\_\_

(2) \_\_\_\_\_

(3) \_\_\_\_\_

(4) \_\_\_\_\_

(5) \_\_\_\_\_

(6) \_\_\_\_\_

(7) \_\_\_\_\_

Signatures: \_\_\_\_\_

\_\_\_\_\_

\_\_\_\_\_

**Date** \_\_\_\_\_

1. Description of lifted object(s) \_\_\_\_\_  
\_\_\_\_\_
2. Weight of object to be lifted \_\_\_\_\_
3. How was the weight of the object obtained? \_\_\_\_\_  
\_\_\_\_\_
4. Crane Info.            Make \_\_\_\_\_  
                                  Model \_\_\_\_\_  
                                  Equipment Number \_\_\_\_\_  
                                  Serial Number \_\_\_\_\_

- |   |   |
|---|---|
| 5. Total deductions for crane--jib, wire rope, block, ball, etc.....  |   |
| 6. Total weight of all rigging (slings, shackles, bars, etc.) used in the lift.....                                 |   |
| <b>7. Total lifted load. Determined by adding lines 2,5,6.....</b>  |   |
| 8. What is the planned radius of the lift. (at the longest point).....  |   |
| 9. What is the rated capacity of the crane you were using at the radius listed above?.....                          |   |
| 10. Divide line 7 by 9 for percent of load chart used. If over 75% of chart, a critical lift plan is necessary..... | % |

**All employees involved must sign off on the lines provided below.**

\_\_\_\_\_  
\_\_\_\_\_  
\_\_\_\_\_ Supt \_\_\_\_\_

**Note: Use the back of this page to write a lift specific Job Hazard Analysis.**

# LIFTING CRANE SAFETY TO NEW HEIGHTS

Date \_\_\_\_\_

## On the Spot Lift Plan Hazard Analysis

Operation: \_\_\_\_\_

Procedure: (1) \_\_\_\_\_

(2) \_\_\_\_\_

(3) \_\_\_\_\_

(4) \_\_\_\_\_

(5) \_\_\_\_\_

(6) \_\_\_\_\_

(7) \_\_\_\_\_

Hazards: (1) \_\_\_\_\_

(2) \_\_\_\_\_

(3) \_\_\_\_\_

(4) \_\_\_\_\_

(5) \_\_\_\_\_

(6) \_\_\_\_\_

(7) \_\_\_\_\_

Precautions: (1) \_\_\_\_\_

(2) \_\_\_\_\_

(3) \_\_\_\_\_

(4) \_\_\_\_\_

(5) \_\_\_\_\_

(6) \_\_\_\_\_

(7) \_\_\_\_\_

Signatures: \_\_\_\_\_

\_\_\_\_\_

\_\_\_\_\_

**Date** \_\_\_\_\_

1. Description of lifted object(s) \_\_\_\_\_  
\_\_\_\_\_
2. Weight of object to be lifted \_\_\_\_\_
3. How was the weight of the object obtained? \_\_\_\_\_  
\_\_\_\_\_
4. Crane Info.            Make \_\_\_\_\_  
                                  Model \_\_\_\_\_  
                                  Equipment Number \_\_\_\_\_  
                                  Serial Number \_\_\_\_\_

- |   |   |
|---|---|
| 5. Total deductions for crane--jib, wire rope, block, ball, etc.....  |   |
| 6. Total weight of all rigging (slings, shackles, bars, etc.) used in the lift.....                                 |   |
| <b>7. Total lifted load. Determined by adding lines 2,5,6.....</b>  |   |
| 8. What is the planned radius of the lift. (at the longest point).....  |   |
| 9. What is the rated capacity of the crane you were using at the radius listed above?.....                          |   |
| 10. Divide line 7 by 9 for percent of load chart used. If over 75% of chart, a critical lift plan is necessary..... | % |

**All employees involved must sign off on the lines provided below.**

\_\_\_\_\_  
\_\_\_\_\_  
\_\_\_\_\_ Supt \_\_\_\_\_

**Note: Use the back of this page to write a lift specific Job Hazard Analysis.**

# LIFTING CRANE SAFETY TO NEW HEIGHTS

Date \_\_\_\_\_

## On the Spot Lift Plan Hazard Analysis

Operation: \_\_\_\_\_

Procedure: (1) \_\_\_\_\_

(2) \_\_\_\_\_

(3) \_\_\_\_\_

(4) \_\_\_\_\_

(5) \_\_\_\_\_

(6) \_\_\_\_\_

(7) \_\_\_\_\_

Hazards: (1) \_\_\_\_\_

(2) \_\_\_\_\_

(3) \_\_\_\_\_

(4) \_\_\_\_\_

(5) \_\_\_\_\_

(6) \_\_\_\_\_

(7) \_\_\_\_\_

Precautions: (1) \_\_\_\_\_

(2) \_\_\_\_\_

(3) \_\_\_\_\_

(4) \_\_\_\_\_

(5) \_\_\_\_\_

(6) \_\_\_\_\_

(7) \_\_\_\_\_

Signatures: \_\_\_\_\_

\_\_\_\_\_

\_\_\_\_\_



# LIFTING CRANE SAFETY TO NEW HEIGHTS

Date \_\_\_\_\_

## On the Spot Lift Plan Hazard Analysis

Operation: \_\_\_\_\_

Procedure: (1) \_\_\_\_\_

(2) \_\_\_\_\_

(3) \_\_\_\_\_

(4) \_\_\_\_\_

(5) \_\_\_\_\_

(6) \_\_\_\_\_

(7) \_\_\_\_\_

Hazards: (1) \_\_\_\_\_

(2) \_\_\_\_\_

(3) \_\_\_\_\_

(4) \_\_\_\_\_

(5) \_\_\_\_\_

(6) \_\_\_\_\_

(7) \_\_\_\_\_

Precautions: (1) \_\_\_\_\_

(2) \_\_\_\_\_

(3) \_\_\_\_\_

(4) \_\_\_\_\_

(5) \_\_\_\_\_

(6) \_\_\_\_\_

(7) \_\_\_\_\_

Signatures: \_\_\_\_\_

\_\_\_\_\_

\_\_\_\_\_

**Date** \_\_\_\_\_

1. Description of lifted object(s) \_\_\_\_\_  
\_\_\_\_\_
2. Weight of object to be lifted \_\_\_\_\_
3. How was the weight of the object obtained? \_\_\_\_\_  
\_\_\_\_\_
4. Crane Info.            Make \_\_\_\_\_  
                                 Model \_\_\_\_\_  
                                 Equipment Number \_\_\_\_\_  
                                 Serial Number \_\_\_\_\_

- |   |  |
|---|--|
| 5. Total deductions for crane--jib, wire rope, block, ball, etc.....  |  |
| 6. Total weight of all rigging (slings, shackles, bars, etc.) used in the lift.....                                 |  |
| <b>7. Total lifted load. Determined by adding lines 2,5,6.....</b>  |  |
| 8. What is the planned radius of the lift. (at the longest point).....  |  |
| 9. What is the rated capacity of the crane you were using at the radius listed above?.....                          |  |
| 10. Divide line 7 by 9 for percent of load chart used. If over 75% of chart, a critical lift plan is necessary..... |  |

**All employees involved must sign off on the lines provided below.**

\_\_\_\_\_  
\_\_\_\_\_  
\_\_\_\_\_ Supt \_\_\_\_\_

**Note: Use the back of this page to write a lift specific Job Hazard Analysis.**

# LIFTING CRANE SAFETY TO NEW HEIGHTS

Date \_\_\_\_\_

## On the Spot Lift Plan Hazard Analysis

Operation: \_\_\_\_\_

Procedure: (1) \_\_\_\_\_

(2) \_\_\_\_\_

(3) \_\_\_\_\_

(4) \_\_\_\_\_

(5) \_\_\_\_\_

(6) \_\_\_\_\_

(7) \_\_\_\_\_

Hazards: (1) \_\_\_\_\_

(2) \_\_\_\_\_

(3) \_\_\_\_\_

(4) \_\_\_\_\_

(5) \_\_\_\_\_

(6) \_\_\_\_\_

(7) \_\_\_\_\_

Precautions: (1) \_\_\_\_\_

(2) \_\_\_\_\_

(3) \_\_\_\_\_

(4) \_\_\_\_\_

(5) \_\_\_\_\_

(6) \_\_\_\_\_

(7) \_\_\_\_\_

Signatures: \_\_\_\_\_

\_\_\_\_\_

\_\_\_\_\_

**Date** \_\_\_\_\_

1. Description of lifted object(s) \_\_\_\_\_  
\_\_\_\_\_
2. Weight of object to be lifted \_\_\_\_\_
3. How was the weight of the object obtained? \_\_\_\_\_  
\_\_\_\_\_
4. Crane Info.            Make \_\_\_\_\_  
                                  Model \_\_\_\_\_  
                                  Equipment Number \_\_\_\_\_  
                                  Serial Number \_\_\_\_\_

- |   |   |
|---|---|
| 5. Total deductions for crane--jib, wire rope, block, ball, etc.....  |   |
| 6. Total weight of all rigging (slings, shackles, bars, etc.) used in the lift.....                                 |   |
| <b>7. Total lifted load. Determined by adding lines 2,5,6.....</b>  |   |
| 8. What is the planned radius of the lift. (at the longest point).....  |   |
| 9. What is the rated capacity of the crane you were using at the radius listed above?.....                          |   |
| 10. Divide line 7 by 9 for percent of load chart used. If over 75% of chart, a critical lift plan is necessary..... | % |

**All employees involved must sign off on the lines provided below.**

	Supt

**Note: Use the back of this page to write a lift specific Job Hazard Analysis.**

# LIFTING CRANE SAFETY TO NEW HEIGHTS

Date \_\_\_\_\_

## On the Spot Lift Plan Hazard Analysis

Operation: \_\_\_\_\_

Procedure: (1) \_\_\_\_\_

(2) \_\_\_\_\_

(3) \_\_\_\_\_

(4) \_\_\_\_\_

(5) \_\_\_\_\_

(6) \_\_\_\_\_

(7) \_\_\_\_\_

Hazards: (1) \_\_\_\_\_

(2) \_\_\_\_\_

(3) \_\_\_\_\_

(4) \_\_\_\_\_

(5) \_\_\_\_\_

(6) \_\_\_\_\_

(7) \_\_\_\_\_

Precautions: (1) \_\_\_\_\_

(2) \_\_\_\_\_

(3) \_\_\_\_\_

(4) \_\_\_\_\_

(5) \_\_\_\_\_

(6) \_\_\_\_\_

(7) \_\_\_\_\_

Signatures: \_\_\_\_\_

\_\_\_\_\_

\_\_\_\_\_



# LIFTING CRANE SAFETY TO NEW HEIGHTS

Date \_\_\_\_\_

## On the Spot Lift Plan Hazard Analysis

Operation: \_\_\_\_\_

Procedure: (1) \_\_\_\_\_

(2) \_\_\_\_\_

(3) \_\_\_\_\_

(4) \_\_\_\_\_

(5) \_\_\_\_\_

(6) \_\_\_\_\_

(7) \_\_\_\_\_

Hazards: (1) \_\_\_\_\_

(2) \_\_\_\_\_

(3) \_\_\_\_\_

(4) \_\_\_\_\_

(5) \_\_\_\_\_

(6) \_\_\_\_\_

(7) \_\_\_\_\_

Precautions: (1) \_\_\_\_\_

(2) \_\_\_\_\_

(3) \_\_\_\_\_

(4) \_\_\_\_\_

(5) \_\_\_\_\_

(6) \_\_\_\_\_

(7) \_\_\_\_\_

Signatures: \_\_\_\_\_

\_\_\_\_\_

\_\_\_\_\_

**Date** \_\_\_\_\_

1. Description of lifted object(s) \_\_\_\_\_  
\_\_\_\_\_
2. Weight of object to be lifted \_\_\_\_\_
3. How was the weight of the object obtained? \_\_\_\_\_  
\_\_\_\_\_
4. Crane Info.            Make \_\_\_\_\_  
                                  Model \_\_\_\_\_  
                                  Equipment Number \_\_\_\_\_  
                                  Serial Number \_\_\_\_\_

- |   |   |
|---|---|
| 5. Total deductions for crane--jib, wire rope, block, ball, etc.....  |   |
| 6. Total weight of all rigging (slings, shackles, bars, etc.) used in the lift.....                                 |   |
| <b>7. Total lifted load. Determined by adding lines 2,5,6.....</b>  |   |
| 8. What is the planned radius of the lift. (at the longest point).....  |   |
| 9. What is the rated capacity of the crane you were using at the radius listed above?.....                          |   |
| 10. Divide line 7 by 9 for percent of load chart used. If over 75% of chart, a critical lift plan is necessary..... | % |

**All employees involved must sign off on the lines provided below.**

\_\_\_\_\_  
\_\_\_\_\_  
\_\_\_\_\_ Supt \_\_\_\_\_

**Note: Use the back of this page to write a lift specific Job Hazard Analysis.**

# LIFTING CRANE SAFETY TO NEW HEIGHTS

Date \_\_\_\_\_

## On the Spot Lift Plan Hazard Analysis

Operation: \_\_\_\_\_

Procedure: (1) \_\_\_\_\_

(2) \_\_\_\_\_

(3) \_\_\_\_\_

(4) \_\_\_\_\_

(5) \_\_\_\_\_

(6) \_\_\_\_\_

(7) \_\_\_\_\_

Hazards: (1) \_\_\_\_\_

(2) \_\_\_\_\_

(3) \_\_\_\_\_

(4) \_\_\_\_\_

(5) \_\_\_\_\_

(6) \_\_\_\_\_

(7) \_\_\_\_\_

Precautions: (1) \_\_\_\_\_

(2) \_\_\_\_\_

(3) \_\_\_\_\_

(4) \_\_\_\_\_

(5) \_\_\_\_\_

(6) \_\_\_\_\_

(7) \_\_\_\_\_

Signatures: \_\_\_\_\_

\_\_\_\_\_

\_\_\_\_\_

**Date** \_\_\_\_\_

1. Description of lifted object(s) \_\_\_\_\_  
\_\_\_\_\_
2. Weight of object to be lifted \_\_\_\_\_
3. How was the weight of the object obtained? \_\_\_\_\_  
\_\_\_\_\_
4. Crane Info.            Make \_\_\_\_\_  
                                  Model \_\_\_\_\_  
                                  Equipment Number \_\_\_\_\_  
                                  Serial Number \_\_\_\_\_

- |   |   |
|---|---|
| 5. Total deductions for crane--jib, wire rope, block, ball, etc.....  |   |
| 6. Total weight of all rigging (slings, shackles, bars, etc.) used in the lift.....                                 |   |
| <b>7. Total lifted load. Determined by adding lines 2,5,6.....</b>  |   |
| 8. What is the planned radius of the lift. (at the longest point).....  |   |
| 9. What is the rated capacity of the crane you were using at the radius listed above?.....                          |   |
| 10. Divide line 7 by 9 for percent of load chart used. If over 75% of chart, a critical lift plan is necessary..... |   |
|   | % |

**All employees involved must sign off on the lines provided below.**

	Supt

**Note: Use the back of this page to write a lift specific Job Hazard Analysis.**

# LIFTING CRANE SAFETY TO NEW HEIGHTS

Date \_\_\_\_\_

## On the Spot Lift Plan Hazard Analysis

Operation: \_\_\_\_\_

Procedure: (1) \_\_\_\_\_

(2) \_\_\_\_\_

(3) \_\_\_\_\_

(4) \_\_\_\_\_

(5) \_\_\_\_\_

(6) \_\_\_\_\_

(7) \_\_\_\_\_

Hazards: (1) \_\_\_\_\_

(2) \_\_\_\_\_

(3) \_\_\_\_\_

(4) \_\_\_\_\_

(5) \_\_\_\_\_

(6) \_\_\_\_\_

(7) \_\_\_\_\_

Precautions: (1) \_\_\_\_\_

(2) \_\_\_\_\_

(3) \_\_\_\_\_

(4) \_\_\_\_\_

(5) \_\_\_\_\_

(6) \_\_\_\_\_

(7) \_\_\_\_\_

Signatures: \_\_\_\_\_

\_\_\_\_\_

\_\_\_\_\_

**Date** \_\_\_\_\_

1. Description of lifted object(s) \_\_\_\_\_  
\_\_\_\_\_
2. Weight of object to be lifted \_\_\_\_\_
3. How was the weight of the object obtained? \_\_\_\_\_  
\_\_\_\_\_
4. Crane Info.            Make \_\_\_\_\_  
                                  Model \_\_\_\_\_  
                                  Equipment Number \_\_\_\_\_  
                                  Serial Number \_\_\_\_\_

- |   |   |
|---|---|
| 5. Total deductions for crane--jib, wire rope, block, ball, etc.....  |   |
| 6. Total weight of all rigging (slings, shackles, bars, etc.) used in the lift.....                                 |   |
| <b>7. Total lifted load. Determined by adding lines 2,5,6.....</b>  |   |
| 8. What is the planned radius of the lift. (at the longest point).....  |   |
| 9. What is the rated capacity of the crane you were using at the radius listed above?.....                          |   |
| 10. Divide line 7 by 9 for percent of load chart used. If over 75% of chart, a critical lift plan is necessary..... | % |

**All employees involved must sign off on the lines provided below.**

\_\_\_\_\_  
\_\_\_\_\_  
\_\_\_\_\_ Supt \_\_\_\_\_

**Note: Use the back of this page to write a lift specific Job Hazard Analysis.**

# LIFTING CRANE SAFETY TO NEW HEIGHTS

Date \_\_\_\_\_

## On the Spot Lift Plan Hazard Analysis

Operation: \_\_\_\_\_

Procedure: (1) \_\_\_\_\_

(2) \_\_\_\_\_

(3) \_\_\_\_\_

(4) \_\_\_\_\_

(5) \_\_\_\_\_

(6) \_\_\_\_\_

(7) \_\_\_\_\_

Hazards: (1) \_\_\_\_\_

(2) \_\_\_\_\_

(3) \_\_\_\_\_

(4) \_\_\_\_\_

(5) \_\_\_\_\_

(6) \_\_\_\_\_

(7) \_\_\_\_\_

Precautions: (1) \_\_\_\_\_

(2) \_\_\_\_\_

(3) \_\_\_\_\_

(4) \_\_\_\_\_

(5) \_\_\_\_\_

(6) \_\_\_\_\_

(7) \_\_\_\_\_

Signatures: \_\_\_\_\_

\_\_\_\_\_

\_\_\_\_\_

**Date** \_\_\_\_\_

1. Description of lifted object(s) \_\_\_\_\_  
\_\_\_\_\_
2. Weight of object to be lifted \_\_\_\_\_
3. How was the weight of the object obtained? \_\_\_\_\_  
\_\_\_\_\_
4. Crane Info.            Make \_\_\_\_\_  
                                  Model \_\_\_\_\_  
                                  Equipment Number \_\_\_\_\_  
                                  Serial Number \_\_\_\_\_

- |   |   |
|---|---|
| 5. Total deductions for crane--jib, wire rope, block, ball, etc.....  |   |
| 6. Total weight of all rigging (slings, shackles, bars, etc.) used in the lift.....                                 |   |
| <b>7. Total lifted load. Determined by adding lines 2,5,6.....</b>  |   |
| 8. What is the planned radius of the lift. (at the longest point).....  |   |
| 9. What is the rated capacity of the crane you were using at the radius listed above?.....                          |   |
| 10. Divide line 7 by 9 for percent of load chart used. If over 75% of chart, a critical lift plan is necessary..... | % |

**All employees involved must sign off on the lines provided below.**

\_\_\_\_\_  
\_\_\_\_\_  
\_\_\_\_\_ Supt \_\_\_\_\_

**Note: Use the back of this page to write a lift specific Job Hazard Analysis.**

# LIFTING CRANE SAFETY TO NEW HEIGHTS

Date \_\_\_\_\_

## On the Spot Lift Plan Hazard Analysis

Operation: \_\_\_\_\_

Procedure: (1) \_\_\_\_\_

(2) \_\_\_\_\_

(3) \_\_\_\_\_

(4) \_\_\_\_\_

(5) \_\_\_\_\_

(6) \_\_\_\_\_

(7) \_\_\_\_\_

Hazards: (1) \_\_\_\_\_

(2) \_\_\_\_\_

(3) \_\_\_\_\_

(4) \_\_\_\_\_

(5) \_\_\_\_\_

(6) \_\_\_\_\_

(7) \_\_\_\_\_

Precautions: (1) \_\_\_\_\_

(2) \_\_\_\_\_

(3) \_\_\_\_\_

(4) \_\_\_\_\_

(5) \_\_\_\_\_

(6) \_\_\_\_\_

(7) \_\_\_\_\_

Signatures: \_\_\_\_\_

\_\_\_\_\_

\_\_\_\_\_

**Date** \_\_\_\_\_

1. Description of lifted object(s) \_\_\_\_\_  
\_\_\_\_\_
2. Weight of object to be lifted \_\_\_\_\_
3. How was the weight of the object obtained? \_\_\_\_\_  
\_\_\_\_\_
4. Crane Info.            Make \_\_\_\_\_  
                                  Model \_\_\_\_\_  
                                  Equipment Number \_\_\_\_\_  
                                  Serial Number \_\_\_\_\_

- |   |  |
|---|--|
| 5. Total deductions for crane--jib, wire rope, block, ball, etc.....  |  |
| 6. Total weight of all rigging (slings, shackles, bars, etc.) used in the lift.....                                 |  |
| <b>7. Total lifted load. Determined by adding lines 2,5,6.....</b>  |  |
| 8. What is the planned radius of the lift. (at the longest point).....  |  |
| 9. What is the rated capacity of the crane you were using at the radius listed above?.....                          |  |
| 10. Divide line 7 by 9 for percent of load chart used. If over 75% of chart, a critical lift plan is necessary..... |  |

**All employees involved must sign off on the lines provided below.**

\_\_\_\_\_  
\_\_\_\_\_  
\_\_\_\_\_ Supt \_\_\_\_\_

**Note: Use the back of this page to write a lift specific Job Hazard Analysis.**

# LIFTING CRANE SAFETY TO NEW HEIGHTS

Date \_\_\_\_\_

## On the Spot Lift Plan Hazard Analysis

Operation: \_\_\_\_\_

Procedure: (1) \_\_\_\_\_

(2) \_\_\_\_\_

(3) \_\_\_\_\_

(4) \_\_\_\_\_

(5) \_\_\_\_\_

(6) \_\_\_\_\_

(7) \_\_\_\_\_

Hazards: (1) \_\_\_\_\_

(2) \_\_\_\_\_

(3) \_\_\_\_\_

(4) \_\_\_\_\_

(5) \_\_\_\_\_

(6) \_\_\_\_\_

(7) \_\_\_\_\_

Precautions: (1) \_\_\_\_\_

(2) \_\_\_\_\_

(3) \_\_\_\_\_

(4) \_\_\_\_\_

(5) \_\_\_\_\_

(6) \_\_\_\_\_

(7) \_\_\_\_\_

Signatures: \_\_\_\_\_

\_\_\_\_\_

\_\_\_\_\_

# VERBAL CRANE SIGNALS

## HOISTING

Fast	Up Up
	Up
	Up Easy
Stop	High

## BOOMING

Fast	Boom Up
	Easy Boom
Stop	Boom

## SWINGING

Fast	Swing Right
	Easy Swing
Stop	Swing

Fast	Down Down
	Down
Stop	High

Fast	Down Down
	Easy Boom
Stop	Boom

Fast	Swing Left
	Easy Swing
Stop	Swing

## Travel

Fast	Travel Forward
	Easy Travel
Stop	Travel

## Scoping

Scope In
Scope

## Trolleying

Fast	Trolley In
	Easy Trolley
Stop	Trolley

Fast	Travel Backward
	Easy Travel
Stop	Travel

Scope Out
Scope

Fast	Trolley In
	Easy Trolley
Stop	Trolley in

---

## Raising a load

Up Choker  
Choker  
Up

## unhooking from a load

Down and Cut Loose  
Your Loose  
Up

## crane functions

Must Be Given in  
Inches or Feet

**IM**