

GROVE®

TMS800E

product guide

features

- 41-128 ft. (12.6-39 m) 4 section full power Mega Form boom
- 33-56 ft. (10-17 m) manual offset bi-fold swingaway
- 2 x 20 ft. intermediate lattice inserts
- 24,000 lb. (10 886 kg) counterweight with hydraulic removal system
- Cummins ISM 450, six cylinder after cooled 450 hp (336 kW)
- Front and rear air ride suspension



contents

Features

2

Specifications

3

Dimensions

5

Travel Proposal

6

Working Range

7

Main Boom and Swingaway Charts

9

Swingaway Charts w/one or two 20' inserts

23

Load Handling

30

Truck Mounted Hydraulic Crane

features

2

For improved up and over reach, a bifold lattice extension is available on the TMS800E and manually offsets from 0° to 40°.



Standard front & rear air ride suspension provides comfortable ride at max speed of 65 mph (105 Km/h)

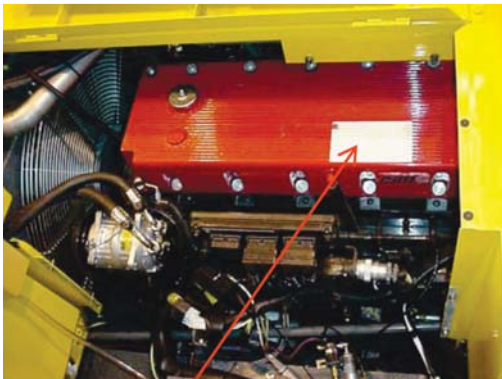

Electronically controlled Cummins ISM450 diesel engine provides plenty of power, on highway and at the jobsite.



The Grove MEGAFORM™ boom shape eliminates weight and increases capacity compared to conventional shapes.

Superstructure

Boom

41 ft. - 128 ft. (12.5 m - 39 m) four section, full power MegaForm boom.

Maximum Tip Height: 135 ft. (41.1 m).

Boom Nose

Four nylatron sheaves, mounted on heavy duty tapered roller bearings with removable pin type rope guards. Quick reeve boom nose. Removable auxiliary boom nose with removable pin type rope guard.

Boom Elevation

Single lift cylinder with safety valve provides boom angle from -3° to +78°.

Offsettable Lattice Extension

33 - 56 ft. (10 - 17 m) bifold lattice swingaway extension, manual offsettable at 0°, 20° and 40°.

Maximum tip height: 191 ft. (58.2 m)

*Lattice Jib Extensions

Two 20 ft. (6.1 m) inserts for use with lattice swingaway extension to increase length up to 76 ft. (23.2 m) or 96 ft. (29.3 m).

Maximum tip height: 230 ft. (70.1 m)

Load Moment & Anti-Two Block System

Standard "Graphics Display" load moment and anti-two block system with audio-visual warning and control lever lockout. These systems provide electronic display of boom angle, boom length, radius, tip height, relative load moment, maximum permissible load, load indication and warning of impending two-block condition. The standard "**Work Area Definition System**" allows the operator to pre-select and define safe working areas. If the crane approaches the pre-set limits, audio-visual warnings aid the operator in avoiding job-site obstructions.

Cab

All aluminum constructed cab with acoustical lining, **hydraulically tiltable** (0° to +20°). Includes tinted safety glass, adjustable operator's seat, sliding windows in side and rear, hinged skylight with wiper, skylight sunscreen. Other features include hot water heater/defroster, armrest integrated dual axis crane controls, and ergonomically arranged instrumentation.

Swing

Axial piston fixed displacement motor and planetary gear box. Infinitely variable to 1.7 rpm. Holding brake and service brake.

Counterweight

8,000 lbs. (3 629 kg) consisting of various sections with hydraulic installation/removal system.

*Optional "Heavy Lift" package consisting of (1) 4,000 lb. (1 814 kg) and (1) 6,000 lb. (2 722 kg) section, for a total of 18,000 lb. (8 165 kg).

*Optional "XL" counterweight package consisting of (1) 6,000 lb. (2721 kg) slab, (1) 4000 lb. (1814 kg) slab and (2) 3,000 lb. (1361 kg) wing weights in addition to standard; for a total of 24,000 lb. (10886 kg) of counterweight.

Hydraulic System

1 piston and 3 gear type pumps with a total capacity of 179 gpm (678 l/m). Maximum operating pressure, 4000 psi (27.6 MPa).

Thermostatically controlled oil cooler keeps oil at optimum operating temperature.

Tank capacity: 183 gal. (693 l)

Hoist

Main and auxiliary hoist are powered by axial piston motor with planetary gear and brake. "Thumb-thumper" hoist drum rotation indicator alerts operator of hoist movement.

Single Line Pull:	1st Layer: 20,250 lb. (9 185 kg)
	3rd Layer: 17,010 lb. (7 716 kg)
	5th Layer: 14,660 lb. (6 650 kg)

Maximum Line Speed: 514 FPM (157 m/min)

Maximum Permissible Line Pull:	16,800 lb. (7 620 kg) 6X36 rope
	17,160 lb. (7 784 kg) 35X7 rope

Rope Diameter: 3/4 in. (19 mm)

Rope Length:	600 ft. (183 m) Main Hoist
	607 ft. (185 m) Auxiliary Hoist

Rope Type:	6 x 36 EIPS IWRC, Special Flexible
	35 x 7 Flex-x, Rotation Resistant

Maximum Rope Stowage:	841 ft. (256 m)
-----------------------	-----------------

**Denotes optional equipment*

specifications

4

Carrier

Chassis

Triple box section, four-axle carrier, fabricated from high strength, low alloy steel with towing and tie-down lugs.

Outrigger System

Four hydraulic telescoping, two-stage, double box beam outriggers with inverted jack and integral holding valves. Quick release type outrigger floats 24 in. (610 mm) diameter. Three position setting with fully extended, intermediate (50%) extended and fully retracted capacities. Maximum outrigger pad load: 101,800 lb.

Outrigger Controls

Located in the superstructure cab and on either side of the carrier. Crane level indicator (sight bubble).

Engine

Cummins ISM 450 six cylinder turbo-charged and after cooled diesel engine, 661 cu. in. (10.8 L), 450 bhp (298 kW) (gross) @ 1800 RPM. Maximum torque 1,450 ft. lbs. (2102 Nm) @ 1200 RPM.

Equipped with engine compression brake, audio-visual engine distress system, ether cold start aid and cruise control.

Fuel Tank Capacity

97 gallons (367 L).

Transmission

Roadranger Ultra Shift 10 speeds forward, 2 reverse. 2 speed auxiliary transmission.

Drive 8 x 4 x 4.

Steering

Front axles, single circuit, mechanical steering with hydraulic power assist. Turning radius: 45.1 ft.

Axles

Front: (2) beam-type steering axles, 83.4 in. (2.12 m) track.
Rear: (2) single reduction drive axles, 74.5 in. (1.89 m) track. Inter-axle differential locks.

Brakes

S-cam, dual air split system operating on all wheels. Spring-applied, air released parking brake acting on rear axles. Air dryer.

Suspension

Front: Walking beam with air bags and shock absorbers.
Rear: Walking beam with air bags and shock absorbers.

Tires

Front: 445/65R 22.5 tubeless, mounted on aluminum disc wheels.
Rear: 315/80R 22.5 tubeless, mounted on aluminum disc wheels.

Lights

Full lighting package including turn indicators, head, tail, brake, and hazard warning lights.

Cab

One man design, aluminum fabricated with acoustical lining and tinted safety glass throughout. Deluxe fabric covered seat with air adjustment. Complete driving controls and engine instrumentation including tilt telescope steering wheel, tachometer, speedometer, voltmeter, water temp., oil pressure, fuel level, air pressure gauge with A/V warning and engine high temp./low oil pressure A/V warning. Other standard items include hot water heater/defroster, electric windshield wash/wipe, fire extinguisher, seat belt and door lock.

Electrical System

Two 12V – maintenance free batteries provides 12 V electrical system. Standard battery disconnect.

Maximum Speed

65 MPH (104 kph)

Gradeability (Theoretical)

70%

Miscellaneous Standard Equipment

Aluminum fenders with rear storage compartments; dual rear view mirrors; electronic back-up alarm; sling/tool box; tire inflation kit; air cleaner restriction indicator; headache ball stowage; aluminum wheels, datalogger.

*Optional Equipment

- *Flashing Light Package (Includes amber strobe for superstructure and carrier cabs)
- *Air conditioning
- *Dual boom base mounted floodlights
- *Hookblocks
- *Pintle hook (rear)
- *Cross axle differential locks
- *Trailing Boom Package
- *Aluminum outrigger pads
- *Air horn
- *Heavy Counterweight package
- *Tow cable
- *LMI light bar
- *Wind speed indicator
- *Winterfront radiator cover

**Denotes optional equipment*

TMS800E

GROVE

dimensions

5

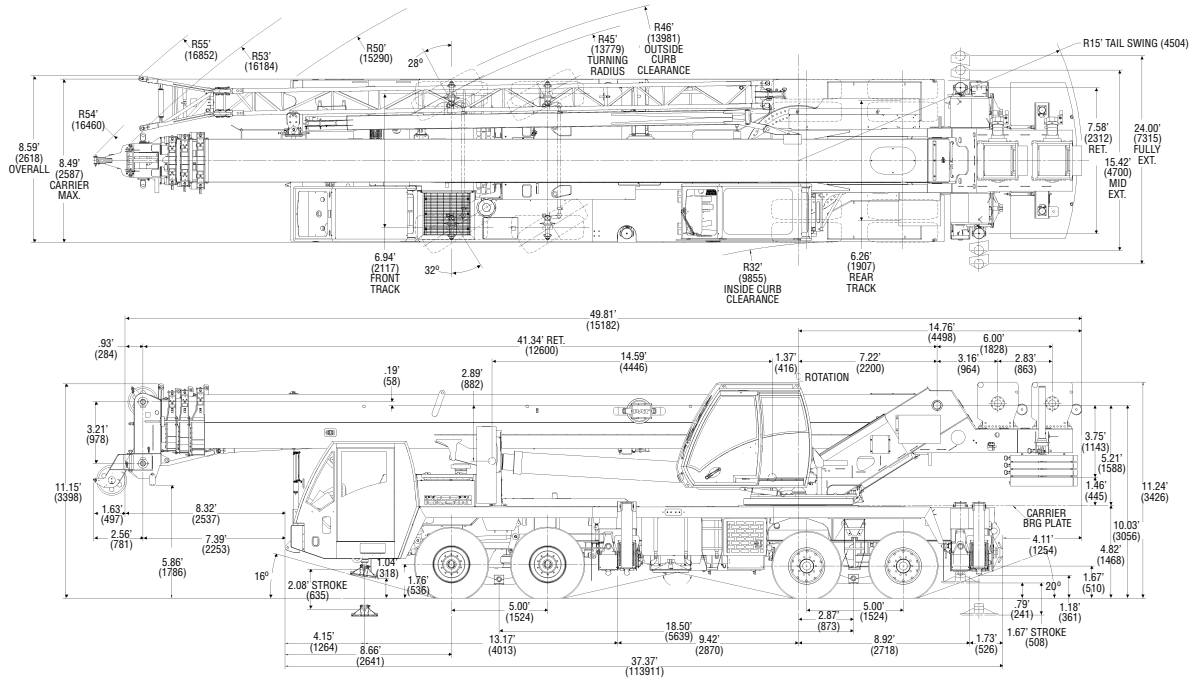

Unit Configuration lb. (kg.)	Front		Rear		Gross	
Maximum Design Allowable Axle/Tire Loads	49,200	(22 317)	60,000	(27 216)	109,200	(49 533)
Basic machine including 128 ft. (39 m) main boom, main hoist with cable, full fuel & hydraulic oil, zero counterweight, 200 lb. driver	38,469	(17 450)	41,439	(18 796)	79,908	(36 246)
Add auxiliary hoist with cable, auxiliary boom nose, 500 lbs. rigging & cribbing, zero counterweight	38,560	(17 491)	42,323	(19 198)	80,883	(36 689)
Add 33-56 ft. Bi-fold swingaway with brackets	41,602	(18 871)	41,913	(19 012)	83,515	(37 882)
Add 40T block tied to front bumper & 10 T headache ball stowed	43,767	(19 853)	41,139	(18 661)	84,906	(38,513)
Add 4,000 lb. counterweight pinned to superstructure	41,663	(18 898)	47,289	(21 450)	88,952	(40 349)
Add 8,000 lb. counterweight (4,000 lb. on deck/4,000 lb. pinned to superstructure)	45,012	(20 417)	47,923	(21 738)	92,935	(42 155)
Add 10,000 lb. counterweight (6,000 lb. on deck/4,000 lb. pinned to superstructure)	46,696	(21 181)	48,239	(21 881)	94,935	(43 063)
Add 12,000 lb. counterweight (8,000 lb. on deck/4,000 lb. pinned to superstructure)	48,391	(21 950)	48,557	(22 025)	96,948	(43 976)
Add 14,000 lb. counterweight (8,000 lb. on deck/6,000 lb. pinned to superstructure)	47,330	(21 469)	51,615	(23 413)	98,945	(44 881)
Add 18,000 lb. counterweight (10,000 lb. on deck/8,000 lb. pinned to superstructure)	47,943	(21 747)	55,018	(24 956)	102,961	(46 703)
Additions:						
Air conditioning carrier	80	(36)	-17	(-8)	63	(29)
Air conditioning superstructure	-32	(-15)	225	(102)	193	(88)
Aluminum outrigger pads	-6	(-3)	-66	(-30)	-72	(-33)
Remove:						
33-56 ft. bi-fold swingaway	-3,042	(-1 380)	410	(186)	-2,632	(-1 194)
40T block	-1,327	(-602)	504	(229)	-823	(-373)
10T headache ball	-838	(-380)	270	(122)	-568	(-258)
Auxiliary hoist cable	448	(203)	-1,237	(-561)	-789	(-358)
Effect per foot of extending boom:	762	(-346)	-762	(346)	0	(0)

Counterweight Configurations

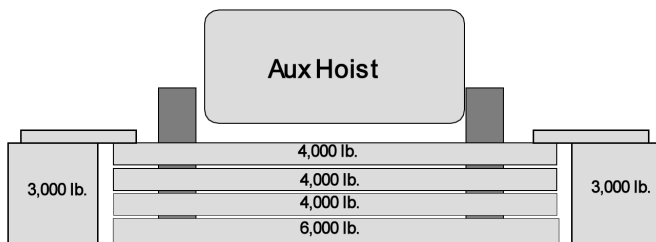

Load Chart Configurations

	4,000 lb.	6,000 lb.	3,000 lb.
8,000 lb.	2X		
10,000 lb.	X	X	
12,000 lb.	3X		
14,000 lb.	2X	X	
18,000 lb.	3X	X	
24,000 lb.	3X	X	2X

TMS800E

dimensions

6

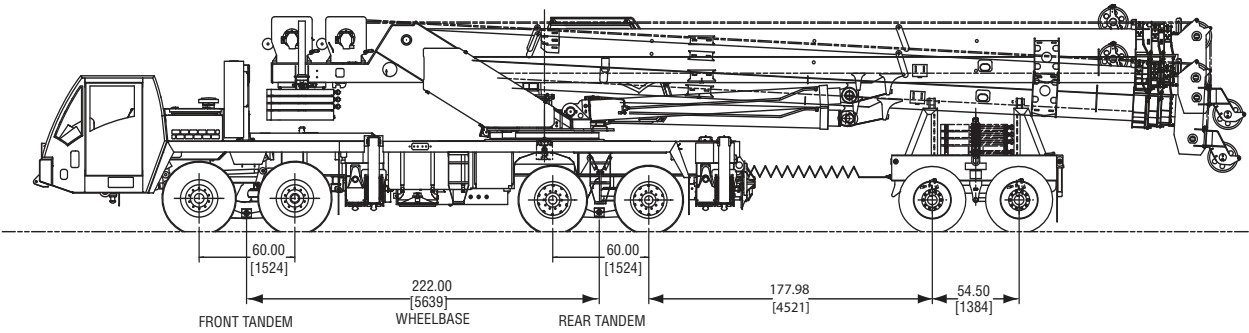

Front
32,272 lb.
(14 638 kg.)

Rear
33,609 lb.
(15 245 kg.)

Dolly
24,825 lb.
(11 261 kg.)

Gross
90,706 lb.
(41 144 kg.)

Unit Configuration:

- 41–128 ft. (12.5-39 m) boom
- 33–56 ft. (10-17 m) stowed swingaway
- Main and auxiliary hoists with cable
- 40 ton hook block hanging from boom nose
- 10 ton headache ball stowed in front tray
- 500 lbs of Rigging & Cribbing
- Driver
- 2 axle boom dolly [6,200 lb. (2 812 kg.)]
- No counterweight

Additions:

- 8,000 lb. (3 629 kg.) counterweight stowed on the chassis deck
- 10,000 lb. (4 536 kg.) counterweight stowed on the boom dolly

Front
39,032 lb.
(17 705 kg.)

Rear
34,878 lb.
(15 821 kg.)

Dolly
34,851 lb.
(15 808 kg.)

Gross
108,761 lb.
(49 334 kg.)

TMS800E

load charts

41.3-128' main boom + 33-56' lattice extension

7

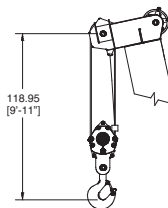
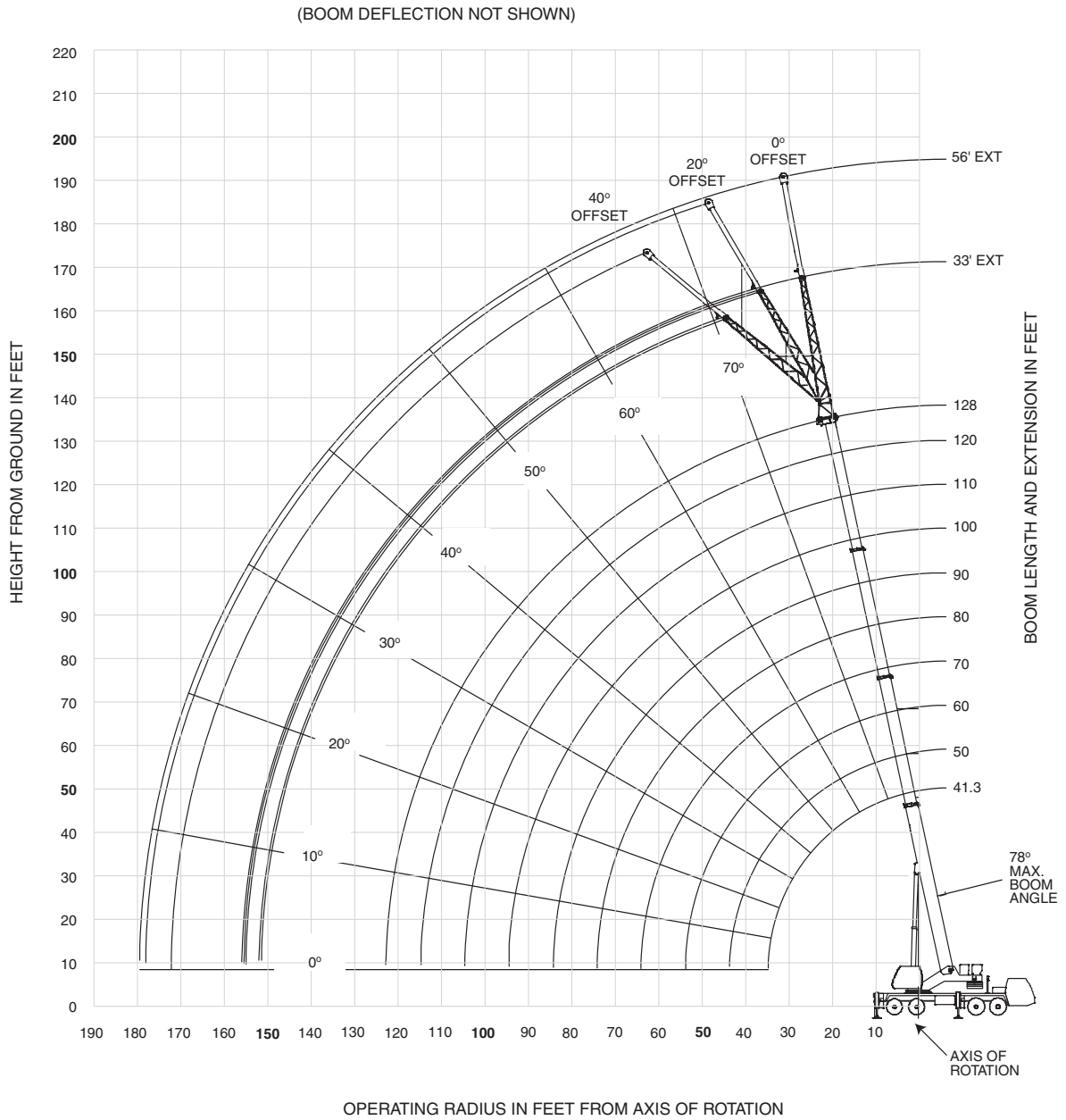

Dimensions are for Largest Grove furnished Hook Block and Overhaul Ball, with Anti-Two Block Activated.

TMS800E

THIS CHART IS ONLY A GUIDE AND SHOULD NOT BE USED TO OPERATE THE CRANE. The individual crane's load chart, operating instructions and other instructional plates must be read and understood prior to operating the crane.

GROVE

working range

41.3-128' main boom + 33-56' lattice extension + 20' or 40' insert

8

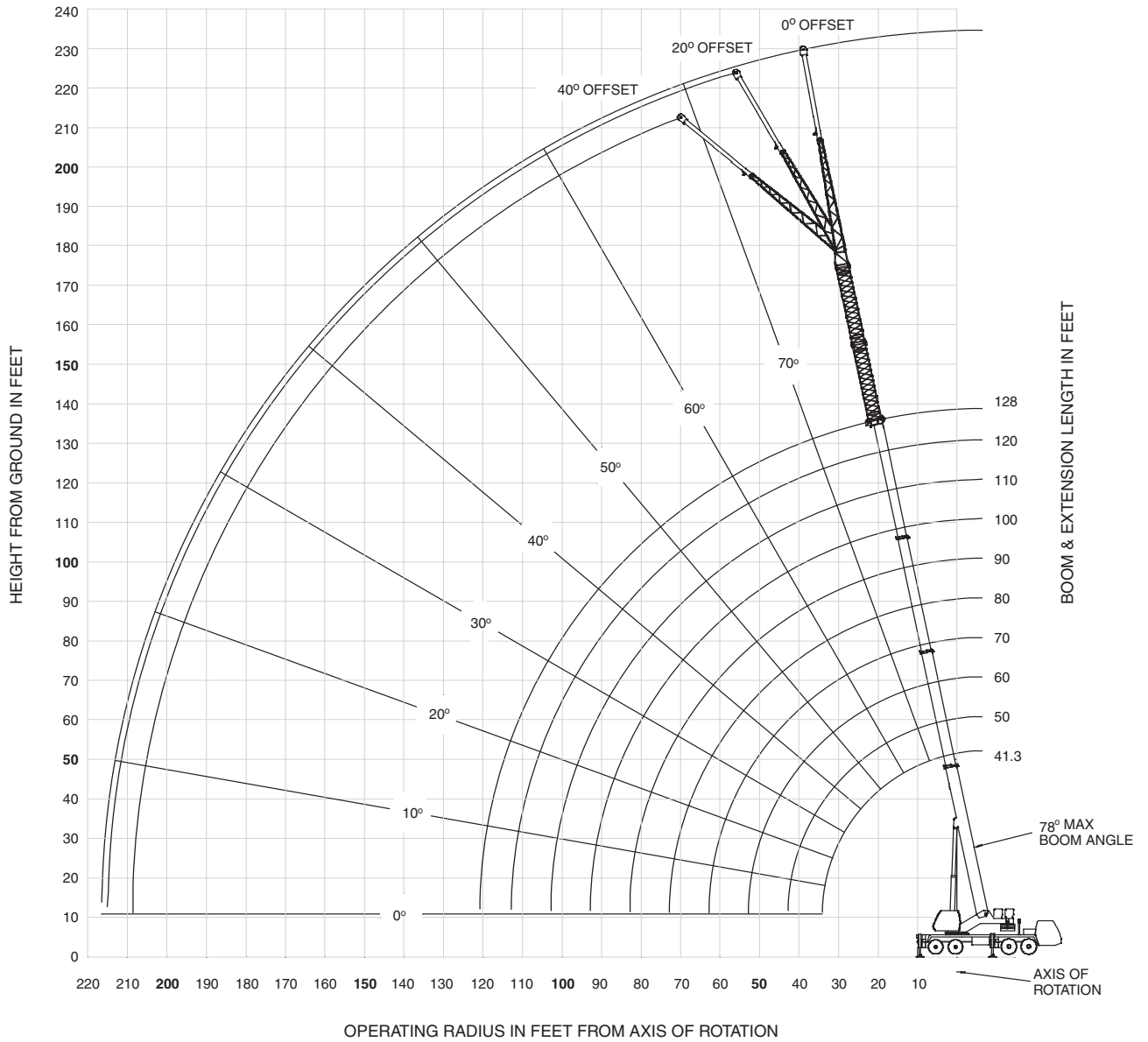

TMS800E

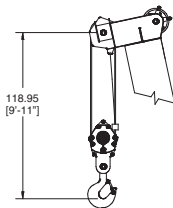

Dimensions are for Largest Grove furnished Hook Block and Overhaul Ball, with Anti-Two Block Activated.

GROVE

THIS CHART IS ONLY A GUIDE AND SHOULD NOT BE USED TO OPERATE THE CRANE. The individual crane's load chart, operating instructions and other instructional plates must be read and understood prior to operating the crane.

load charts

41.3-128 ft. 24,000 lbs 100% 24' 0" spread 360°

	41.3	50	60	**70	80	90	100	110	120	128
8	+160,000 (73)									
9	++150,000 (71.5)	86,000 (75)								
10	147,000 (70)	86,000 (74)	86,000 (77)							
12	130,500 (67)	86,000 (71.5)	86,000 (75)	41,000 (77)						
15	111,000 (62)	86,000 (67.5)	86,000 (71.5)	41,000 (74.5)	39,000 (76.5)					
20	87,650 (53.5)	86,000 (61)	85,900 (66.5)	41,000 (70)	39,000 (73)	38,800 (75)	*38,700 (78)	*31,950 (78)		
25	67,700 (44)	67,450 (54)	67,250 (61)	41,000 (65.5)	39,000 (69)	38,800 (71.5)	38,700 (74)	31,950 (75.5)	*25,750 (78)	*14,600 (78)
30	50,550 (31)	50,800 (46.5)	50,750 (55.5)	41,000 (61)	39,000 (65)	38,800 (68.5)	36,150 (70.5)	31,950 (72.5)	25,750 (74.5)	14,600 (75.5)
35		38,600 (37)	38,750 (49.5)	38,650 (56.5)	38,150 (61)	34,100 (65)	31,350 (67.5)	29,300 (70)	25,750 (72)	14,600 (73)
40		30,300 (24)	30,500 (42)	30,600 (51)	31,550 (57)	30,050 (61)	27,500 (64.5)	25,650 (67.5)	23,900 (69.5)	14,600 (71)
45			24,550 (33.5)	24,700 (45.5)	25,700 (52.5)	26,500 (57.5)	24,400 (61.5)	22,700 (64.5)	21,450 (67)	14,600 (68.5)
50	See Note 16		20,050 (21.5)	20,250 (39)	21,150 (47.5)	22,050 (53.5)	21,850 (58)	20,250 (61.5)	19,100 (64.5)	14,600 (66)
55				16,750 (31.5)	17,650 (42.5)	18,500 (49.5)	19,300 (54.5)	18,200 (58.5)	17,100 (62)	14,600 (64)
60				13,950 (20.5)	14,800 (36.5)	15,650 (45)	16,450 (51)	16,450 (55.5)	15,450 (59)	14,600 (61.5)
65					12,450 (29)	13,300 (40)	14,150 (47)	14,550 (52)	14,000 (56)	13,350 (59)
70					10,500 (18.5)	11,300 (34)	12,150 (42.5)	12,600 (48.5)	12,700 (53)	12,150 (56)
75						9,650 (27.5)	10,500 (38)	10,950 (45)	11,350 (50)	11,050 (53.5)
80						8,220 (17.5)	9,100 (32.5)	9,530 (41)	9,950 (47)	10,100 (50.5)
85							7,870 (26)	8,300 (36.5)	8,710 (43)	9,090 (47.5)
90							6,800 (17)	7,220 (31)	7,620 (39.5)	8,000 (44)
95								6,260 (25)	6,660 (35)	7,030 (40.5)
100								5,410 (16)	5,810 (30)	6,170 (36.5)
105									5,040 (24)	5,410 (32)
110									4,360 (16)	4,720 (27)
115										4,090 (21)
120										3,530 (10)

Minimum boom angle (deg.) for indicated length (no load) 9

Maximum boom length (ft.) at 0 deg. boom angle (no load) 120

#LMI operating code. Refer to LMI manual for instructions.

*This capacity is based upon maximum obtainable boom angle.

Note: () Boom angles are in degrees.

+ Special equipment is required to lift this capacity.

++9 parts of line required to lift this capacity (using aux. boom nose). Refer to Operator's & Safety Handbook for reeving diagram.

Lifting Capacities at Zero Degree Boom Angle

Boom Angle	Main Boom Length in Feet									
	41.3	50	60	**70	80	90	100	110	120	
0°	20,750 (34.1)	15,150 (42.8)	10,500 (52.8)	6,700 (63)	5,100 (72.8)	3,900 (82.8)	2,900 (92.8)	2,000 (102.8)	1,300 (112.8)	

Note: () Reference radii in feet.

**This boom length is with inner-mid fully extended and outer-mid & fly fully retracted.

A6-829-103890

THIS CHART IS ONLY A GUIDE AND SHOULD NOT BE USED TO OPERATE THE CRANE. The individual crane's load chart, operating instructions and other instructional plates must be read and understood prior to operating the crane.

GROVE

TMS800E

load charts

10



	Pounds					
	33 ft. LENGTH			56 ft. LENGTH		
	0° OFFSET	20° OFFSET	40° OFFSET	0° OFFSET	20° OFFSET	40° OFFSET
35	*11,900 (78)					
40	11,900 (75.5)			6,060 (77.5)		
45	11,900 (73.5)			*11,600 (78)		
50	11,900 (71.5)		10,600 (75)	*9,700 (78)		6,060 (74.5)
55	11,900 (70)		9,770 (73)	8,470 (75.5)		6,060 (73)
60	11,000 (68)		9,020 (71)	7,920 (73.5)		6,060 (71)
65	10,000 (66)		8,360 (69.5)	7,430 (72)		6,060 (69.5)
70	9,190 (64)		7,780 (67.5)	6,980 (70)		6,060 (68)
75	8,460 (62)		7,260 (65.5)	6,580 (68)		5,730 (71.5)
80	7,820 (60)		6,790 (63.5)	6,210 (65.5)		5,330 (70)
85	7,250 (58)		6,370 (61)	5,870 (63.5)		4,980 (68)
90	6,740 (55.5)		5,990 (59)	5,560 (61)		4,370 (70)
95	6,290 (53.5)		5,640 (56.5)	5,280 (59)		4,360 (66.5)
100	5,880 (51)		5,320 (54.5)	5,020 (56.5)		4,090 (64.5)
105	5,510 (48.5)		5,030 (52)	4,770 (54)		3,840 (62.5)
110	5,170 (46)		4,760 (49.5)	4,550 (51)		3,680 (60.5)
115	4,780 (43.5)		4,510 (46.5)	4,340 (48.5)		3,480 (74)
120	4,200 (40.5)		4,280 (44)	4,150 (45)		3,200 (66.5)
125	3,660 (37.5)		3,960 (41)			2,970 (60)
130	3,170 (34)		3,420 (37.5)			2,820 (58)
135	2,710 (30.5)		2,930 (34)			2,680 (55.5)
140	2,290 (26.5)		2,470 (29.5)			2,540 (50.5)
145	1,910 (21.5)					2,420 (50.5)
150	1,550 (14.5)					2,270 (47.5)
155						2,140 (39.5)
160						2,100 (35)
165						1,770 (31.5)

Minimum boom angle (°) for indicated length 13 (no load)	28	43.5	19	31.5	46
Maximum boom length (ft.) at 0° boom angle (no load)	110		110		
NOTE: () Boom angles are in degrees. #LMI operating code. Refer to LMI manual for operating instructions. *This capacity is based upon maximum boom angle.					A6-829-103892

NOTES:

- All capacities above the bold line are based on structural strength of boom extension and do not exceed 85% of tipping loads, in accordance with SAE J-765.
- The 33 ft. extension length may be used with single or double part line lifting service. The 56 ft. extension length may be used for single line lifting service only.
- For main boom lengths less than 128 ft. with the boom extension erected, the rated loads are determined by boom angle. Use only the column which corresponds to the boom extension length and offset for which the machine is set up. For boom angles not shown, use rating of the next lower boom angle.
- WARNING:** Operation of this machine with heavier loads than the capacities listed is strictly prohibited. Machine tipping with boom extension occurs rapidly and without advance warning.
- Boom angle is the angle above or below horizontal of the longitudinal axis of the boom base section after lifting rated load.
- Capacities listed are with outriggers properly extended and vertical jacks set only.
- When lifting over the main boom nose with 33 ft. or 56 ft. extension erected, the outriggers must be fully extended or 50% extended (15 ft. 5 in. spread).

TMS800E

load charts

11

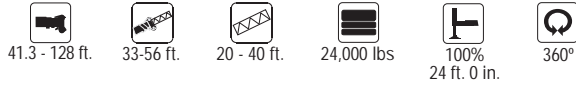

	Pounds					
	76 ft. (56 ft. LENGTH + 1 INSERT)			96 ft. (56 ft. LENGTH + 2 INSERTS)		
	0° OFFSET	20° OFFSET	40° OFFSET	0° OFFSET	20° OFFSET	40° OFFSET
50	4,850 (77.5)					
55	4,850 (76)			3,520 (78)		
60	4,850 (74.5)			3,520 (77)		
65	4,850 (73)	5,290 (78)		3,520 (75.5)		
70	4,850 (71.5)	4,860 (76.5)		3,520 (74)		
75	4,850 (70)	4,470 (75)		3,520 (72.5)	3,740 (77)	
80	4,730 (68.5)	4,110 (73.5)	4,050 (77)	3,520 (71.5)	3,420 (75.5)	
85	4,310 (67)	3,790 (72)	3,500 (75.5)	3,300 (70)	3,100 (74.5)	3,250 (78)
90	3,940 (65.5)	3,500 (70)	3,260 (73.5)	2,970 (68.5)	2,820 (73)	2,720 (76)
95	3,610 (63.5)	3,240 (68.5)	3,030 (72)	2,660 (67)	2,560 (71.5)	2,490 (74.5)
100	3,310 (62)	3,000 (67)	2,830 (70.5)	2,390 (65.5)	2,320 (70)	2,270 (73)
105	3,040 (60.5)	2,770 (65)	2,630 (68.5)	2,140 (64)	2,100 (68.5)	2,070 (71.5)
110	2,790 (59)	2,570 (63.5)	2,450 (66.5)	1,920 (62.5)	1,900 (67)	1,890 (70)
115	2,560 (57)	2,370 (61.5)	2,280 (65)	1,710 (61)	1,710 (65.5)	1,710 (68.5)
120	2,350 (55.5)	2,200 (60)	2,120 (63)	1,520 (59.5)	1,540 (64)	1,550 (66.5)
125	2,160 (53.5)	2,030 (58)	1,970 (61)	1,350 (58)	1,380 (62.5)	1,390 (65)
130	1,990 (52)	1,880 (56.5)	1,830 (59)	1,190 (56.5)	1,230 (60.5)	1,250 (63.5)
135	1,820 (50)	1,730 (54.5)	1,700 (57)	1,040 (55)	1,080 (59)	1,110 (61.5)
140	1,670 (48)	1,590 (52.5)	1,570 (55)			
145	1,530 (46)	1,470 (50.5)	1,450 (52.5)			
150	1,400 (43.5)	1,340 (48)	1,340 (50.5)			
155	1,270 (41.5)	1,230 (46)	1,230 (48)			
160	1,160 (39)	1,120 (43.5)	1,130 (45)			
165	1,050 (36.5)	1,020 (40.5)				

Minimum boom angle (°) for indicated length (no load)	35	39	43.5	53.5	58	60.5
Maximum boom length (ft.) at 0° boom angle (no load)		70			70	

NOTE: () Boom angles are in degrees. A6-829-103894
 #LMI operating code. Refer to LMI manual for operating instructions.
 *This capacity is based upon maximum boom angle.

NOTES:

1. All capacities above the bold line are based on structural strength of boom extension and do not exceed 85% of tipping loads, in accordance with SAE J-765.
2. The 33 ft. extension length may be used with single or double part line lifting service. The 56 ft. extension length may be used for single line lifting service only.
3. For main boom lengths less than 128 ft. with the boom extension erected, the rated loads are determined by boom angle. Use only the column which corresponds to the boom extension length and offset for which the machine is set up. For boom angles not shown, use rating of the next lower boom angle.
4. **WARNING:** Operation of this machine with heavier loads than the capacities listed is strictly prohibited. Machine tipping with boom extension occurs rapidly and without advance warning.
5. Boom angle is the angle above or below horizontal of the longitudinal axis of the boom base section after lifting rated load.
6. Capacities listed are with outriggers properly extended and vertical jacks set only.
7. When lifting over the main boom nose with 33 ft. or 56 ft. extension erected, the outriggers must be fully extended or 50% extended (15 ft. 5 in. spread).

TMS800E

load charts

12



Feet	Main Boom Length in Feet										
	41.3	50	60	**70	80	90	100	110	120	128	
8	+160,000 (73)										
9	++150,000 (71.5)	86,000 (75)									
10	147,000 (70)	86,000 (74)	86,000 (77)								
12	130,500 (67)	86,000 (71.5)	86,000 (75)	41,000 (77)							
15	111,000 (62)	86,000 (67.5)	86,000 (71.5)	41,000 (74.5)	39,000 (76.5)						
20	87,650 (53.5)	86,000 (61)	85,900 (66.5)	41,000 (70)	39,000 (73)	38,800 (75)	*38,700 (78)	*31,950 (78)			
25	63,700 (44)	63,750 (54)	63,300 (61)	41,000 (65.5)	39,000 (69)	38,800 (71.5)	38,700 (74)	31,950 (75.5)	*25,750 (78)	*14,600 (78)	
30	45,450 (31)	45,650 (46.5)	45,600 (55.5)	41,000 (61)	39,000 (65)	38,800 (68.5)	36,150 (70.5)	31,950 (72.5)	25,750 (74.5)	14,600 (75.5)	
35		34,450 (37)	34,550 (49.5)	34,500 (56.5)	35,450 (61)	34,100 (65)	31,350 (67.5)	29,300 (70)	25,750 (72)	14,600 (73)	
40		26,800 (24)	27,000 (42)	27,100 (51)	28,050 (57)	28,950 (61)	27,500 (64.5)	25,650 (67.5)	23,900 (69.5)	14,600 (71)	
45			21,550 (33.5)	21,700 (45.5)	22,650 (52.5)	23,500 (57.5)	24,350 (61.5)	22,700 (64.5)	21,450 (67)	14,600 (68.5)	
50			17,450 (21.5)	17,600 (39)	18,550 (47.5)	19,450 (53.5)	20,200 (58)	20,250 (61.5)	19,100 (64.5)	14,600 (66)	
55				14,400 (31.5)	15,300 (42.5)	16,150 (49.5)	16,950 (54.5)	17,300 (58.5)	17,100 (62)	14,600 (64)	
60				11,800 (20.5)	12,700 (36.5)	13,500 (45)	14,350 (51)	14,750 (55.5)	15,100 (59)	14,600 (61.5)	
65					10,550 (29)	11,350 (40)	12,200 (47)	12,600 (52)	13,000 (56)	13,350 (59)	
70					8,760 (18.5)	9,550 (34)	10,400 (42.5)	10,850 (48.5)	11,250 (53)	11,600 (56)	
75						8,010 (27.5)	8,890 (38)	9,320 (45)	9,740 (50)	10,100 (53.5)	
80						6,690 (17.5)	7,580 (32.5)	8,010 (41)	8,430 (47)	8,790 (50.5)	
85							6,450 (26)	6,880 (36.5)	7,290 (43)	7,670 (47.5)	
90							5,460 (17)	5,880 (31)	6,290 (39.5)	6,670 (44)	
95								5,000 (25)	5,410 (35)	5,780 (40.5)	
100								4,220 (16)	4,620 (30)	4,990 (36.5)	
105									3,920 (24)	4,280 (32)	
110									3,280 (16)	3,650 (27)	
115										3,080 (21)	
120										2,560 (10)	

Minimum boom angle (deg.) for indicated length (no load) 9
 Maximum boom length (ft.) at 0 deg. boom angle (no load) 120
 #LMI operating code. Refer to LMI manual for instructions.
 *This capacity is based upon maximum obtainable boom angle.
 Note: () Boom angles are in degrees.
 + Special equipment is required to lift this capacity.
 ++9 parts of line required to lift this capacity (using aux. boom nose). Refer to Operator's & Safety Handbook for reeving diagram.

Lifting Capacities at Zero Degree Boom Angle

Boom Angle	Main Boom Length in Feet									
	41.3	50	60	**70	80	90	100	110	120	
0°	20,750 (34.1)	15,150 (42.8)	10,500 (52.8)	6,700 (63)	5,100 (72.8)	3,900 (82.8)	2,900 (92.8)	2,000 (102.8)	1,300 (112.8)	

Note: () Reference radii in feet.
 **This boom length is with inner-mid fully extended and outer-mid & fly fully retracted. A6-829-103749

TMS800E

load charts

13



Pounds						
Feet	33 ft. LENGTH			56 ft. LENGTH		
	0° OFFSET	20° OFFSET	40° OFFSET	0° OFFSET	20° OFFSET	40° OFFSET
35	*11,900 (78)					
40	11,900 (75.5)			6,060 (77.5)		
45	11,900 (73.5)			*11,600 (78)		
50	11,900 (71.5)			10,600 (75) *9,700 (78)		
55	11,900 (70)			9,770 (73) 8,470 (75.5)		
60	11,000 (68)			9,020 (71) 7,920 (73.5)		
65	10,000 (66)			8,360 (69.5) 7,430 (72)		
70	9,190 (64)			7,780 (67.5) 6,980 (70)		
75	8,460 (62)			7,260 (65.5) 6,580 (68)		
80	7,820 (60)			6,790 (63.5) 6,210 (65.5)		
85	7,250 (58)			6,370 (61) 5,870 (63.5)		
90	6,740 (55.5)			5,990 (59) 5,560 (61)		
95	6,290 (53.5)			5,640 (56.5) 5,280 (59)		
100	5,750 (51)			5,320 (54.5) 5,020 (56.5)		
105	5,020 (48.5)			5,030 (52) 4,770 (54)		
110	4,360 (46)			4,760 (49.5) 4,550 (51)		
115	3,760 (43.5)			4,150 (46.5) 4,340 (48.5)		
120	3,220 (40.5)			3,560 (44) 3,840 (45)		
125	2,710 (37.5)			3,020 (41)		
130	2,250 (34)			2,520 (37.5)		
135	1,830 (30.5)			2,070 (34)		
140	1,440 (26.5)			1,640 (29.5)		
145	1,080 (21.5)			1,070 (31.5)		
150				1,370 (35)		
155				1,730 (39.5)		
160				2,400 (43)		
				2,540 (50)		
				2,420 (50.5)		
				2,300 (47.5)		
				2,110 (42.5)		
				1,690 (38)		
				1,380 (36)		
				1,060 (32.5)		
Minimum boom angle (°) for indicated length (no load)	20	28	43.5	30	31.5	46
Maximum boom length (ft.) at 0° boom angle (no load)	110			100		

NOTE: () Boom angles are in degrees. #LMI operating code. Refer to LMI manual for operating instructions. *This capacity is based upon maximum boom angle. A6-829-103771

NOTES:

- All capacities above the bold line are based on structural strength of boom extension and do not exceed 85% of tipping loads, in accordance with SAE J-765.
- The 33 ft. extension length may be used with single or double part line lifting service. The 56 ft. extension length may be used for single line lifting service only.
- For main boom lengths less than 128 ft. with the boom extension erected, the rated loads are determined by boom angle. Use only the column which corresponds to the boom extension length and offset for which the machine is set up. For boom angles not shown, use rating of the next lower boom angle.
- WARNING:** Operation of this machine with heavier loads than the capacities listed is strictly prohibited. Machine tipping with boom extension occurs rapidly and without advance warning.
- Boom angle is the angle above or below horizontal of the longitudinal axis of the boom base section after lifting rated load.
- Capacities listed are with outriggers properly extended and vertical jacks set only.
- When lifting over the main boom nose with 33 ft. or 56 ft. extension erected, the outriggers must be fully extended or 50% extended (15 ft. 5 in. spread).

load charts

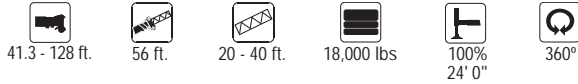

14

Feet	Pounds					
	76 ft. (56 ft. LENGTH + 1 INSERT)			96 ft. (56 ft. LENGTH + 2 INSERTS)		
	0° OFFSET	20° OFFSET	40° OFFSET	0° OFFSET	20° OFFSET	40° OFFSET
50	4,850 (77.5)					
55	4,850 (76)			3,520 (78)		
60	4,850 (74.5)			3,520 (77)		
65	4,850 (73)	5,290 (78)		3,520 (75.5)		
70	4,850 (71.5)	4,860 (76.5)		3,520 (74)		
75	4,850 (70)	4,470 (75)		3,520 (72.5)	3,740 (77)	
80	4,730 (68.5)	4,110 (73.5)	4,050 (77)	3,520 (71.5)	3,420 (75.5)	
85	4,310 (67)	3,790 (72)	3,500 (75.5)	3,300 (70)	3,100 (74.5)	*3,250 (78)
90	3,940 (65.5)	3,500 (70)	3,260 (73.5)	2,970 (68.5)	2,820 (73)	2,720 (76)
95	3,610 (63.5)	3,240 (68.5)	3,030 (72)	2,660 (67)	2,560 (71.5)	2,490 (74.5)
100	3,310 (62)	3,000 (67)	2,830 (70.5)	2,390 (65.5)	2,320 (70)	2,270 (73)
105	3,040 (60.5)	2,770 (65)	2,630 (68.5)	2,140 (64)	2,100 (68.5)	2,070 (71.5)
110	2,790 (59)	2,570 (63.5)	2,450 (66.5)	1,920 (62.5)	1,900 (67)	1,890 (70)
115	2,560 (57)	2,370 (61.5)	2,280 (65)	1,710 (61)	1,710 (65.5)	1,710 (68.5)
120	2,350 (55.5)	2,200 (60)	2,120 (63)	1,520 (59.5)	1,540 (64)	1,550 (66.5)
125	2,160 (53.5)	2,030 (58)	1,970 (61)	1,350 (58)	1,380 (62.5)	1,390 (65)
130	1,990 (52)	1,880 (56.5)	1,830 (59)	1,190 (56.5)	1,230 (60.5)	1,250 (63.5)
135	1,820 (50)	1,730 (54.5)	1,700 (57)	1,040 (55)	1,080 (59)	1,110 (61.5)
140	1,670 (48)	1,590 (52.5)	1,570 (55)			
145	1,530 (46)	1,470 (50.5)	1,450 (52.5)			
150	1,400 (43.5)	1,340 (48)	1,340 (50.5)			
155	1,160 (41.5)	1,230 (46)	1,230 (48)			
160		1,120 (43.5)	1,130 (45)			
Minimum boom angle (°) for indicated length (no load)	39	40.5	43.5	53.5	58	60.5
Maximum boom length (ft.) at 0° boom angle (no load)		70			70	

NOTE: () Boom angles are in degrees. #LMI operating code. Refer to LMI manual for operating instructions. *This capacity is based upon maximum boom angle.

NOTES:

1. All capacities above the bold line are based on structural strength of boom extension and do not exceed 85% of tipping loads, in accordance with SAE J-765.
2. The 56 ft. extension length may be used for single line lifting service only.
3. For main boom lengths less than 128 ft. with the boom extension erected, the rated loads are determined by boom angle. Use only the column which corresponds to the boom extension length and offset for which the machine is set up. For boom angles not shown, use rating of the next lower boom angle.
4. **WARNING:** Operation of this machine with heavier loads than the capacities listed is strictly prohibited. Machine tipping with boom extension occurs rapidly and without advance warning.
5. Boom angle is the angle above or below horizontal of the longitudinal axis of the boom base section after lifting rated load.
6. Capacities listed are with outriggers properly extended and vertical jacks set only.
7. When lifting over the main boom nose with 56 ft. extension erected and inserts, the outriggers must be fully extended and vertical jacks set.

TMS800E

GROVE

THIS CHART IS ONLY A GUIDE AND SHOULD NOT BE USED TO OPERATE THE CRANE. The individual crane's load chart, operating instructions and other instructional plates must be read and understood prior to operating the crane.

load charts

15

Feet	41.3	50	60	**70	80	90	100	110	120	128
8	++150,000 (73)									
9	++150,000 (71.5)									
10	145,500 (70)	86,000 (74)	86,000 (77)							
12	129,000 (67)	86,000 (71.5)	86,000 (75)	41,000 (77)						
15	110,000 (62)	86,000 (67.5)	86,000 (71.5)	41,000 (74.5)	39,000 (76.5)					
20	85,200 (53.5)	84,900 (61)	84,650 (66.5)	41,000 (70)	39,000 (73)	38,800 (75)	*38,700 (78)	*31,950 (78)		
25	59,150 (44)	59,150 (54)	58,700 (61)	41,000 (65.5)	39,000 (69)	38,800 (71.5)	38,700 (74)	31,950 (75.5)	*25,750 (78)	*14,600 (78)
30	41,950 (31)	42,150 (46.5)	42,100 (55.5)	41,000 (61)	39,000 (65)	38,800 (68.5)	36,150 (70.5)	31,950 (72.5)	25,750 (74.5)	14,600 (75.5)
35		31,600 (37)	31,750 (49.5)	31,700 (56.5)	32,600 (61)	33,600 (65)	31,350 (67.5)	29,300 (70)	25,750 (72)	14,600 (73)
40		24,450 (24)	24,650 (42)	24,750 (51)	25,650 (57)	26,550 (61)	27,500 (64.5)	25,650 (67.5)	23,900 (69.5)	14,600 (71)
45		19,500 (33.5)	19,650 (45.5)	19,650 (52.5)	20,650 (57.5)	21,500 (61.5)	22,350 (64.5)	22,650 (67.5)	21,450 (69.5)	14,600 (71)
50		15,650 (21.5)	15,800 (39)	16,750 (47.5)	17,650 (53.5)	18,400 (58)	18,750 (61.5)	19,100 (64.5)	19,100 (66)	14,600 (66)
55			12,800 (31.5)	13,700 (42.5)	14,550 (49.5)	15,350 (54.5)	15,700 (58.5)	16,100 (62)	16,100 (64)	14,600 (64)
60			10,400 (20.5)	11,250 (36.5)	12,050 (45)	12,900 (51)	13,300 (55.5)	13,650 (59)	14,150 (61.5)	14,150 (61.5)
65			9,240 (29)	10,050 (40)	10,900 (47)	11,300 (52)	11,300 (56)	11,700 (59)	12,100 (61.5)	12,100 (61.5)
70			7,550 (18.5)	8,350 (34)	9,220 (42.5)	9,650 (48.5)	10,050 (53)	10,400 (56)	10,400 (56)	10,400 (56)
75				6,900 (27.5)	7,780 (38)	8,210 (45)	8,630 (50)	8,980 (53.5)	8,980 (53.5)	8,980 (53.5)
80				5,660 (17.5)	6,550 (32.5)	6,980 (41)	7,390 (47)	7,760 (50.5)	7,760 (50.5)	7,760 (50.5)
85					5,490 (26)	5,910 (36.5)	6,320 (43)	6,700 (47.5)	6,700 (47.5)	6,700 (47.5)
90						4,560 (17)	4,980 (31)	5,380 (39.5)	5,770 (44)	5,770 (44)
95							4,150 (25)	4,550 (35)	4,930 (40.5)	4,930 (40.5)
100							3,420 (16)	3,810 (30)	4,190 (36.5)	4,190 (36.5)
105								3,150 (24)	3,520 (32)	3,520 (32)
110								2,560 (16)	2,930 (27)	2,930 (27)
115									2,390 (21)	2,390 (21)
120									1,900 (10)	1,900 (10)

Minimum boom angle (deg.) for indicated length (no load) 9
 Maximum boom length (ft.) at 0 deg. boom angle (no load) 120

#LMI operating code. Refer to LMI manual for instructions.
 *This capacity is based upon maximum obtainable boom angle.
 Note: () Boom angles are in degrees.
 ++9 parts of line required to lift this capacity (using aux. boom nose). Refer to Operator's & Safety Handbook for reeving diagram.

Boom Angle	41.3	50	60	**70	80	90	100	110	120
0°	20,750 (34.1)	15,150 (42.8)	10,500 (52.8)	6,700 (63)	5,100 (72.8)	3,900 (82.8)	2,900 (92.8)	2,000 (102.8)	1,300 (112.8)

Note: () Reference radii in feet.
 **This boom length is with inner-mid fully extended and outer-mid & fly fully retracted.

A6-829-103750

TMS800E

load charts

16



Feet	Pounds					
	33 ft. LENGTH			56 ft. LENGTH		
	0° OFFSET	20° OFFSET	40° OFFSET	0° OFFSET	20° OFFSET	40° OFFSET
35	*11,900 (78)					
40	11,900 (75.5)			6,060 (77.5)		
45	11,900 (73.5)	*11,600 (78)		6,060 (76)		
50	11,900 (71.5)	10,600 (75)	*9,700 (78)	6,060 (74.5)		
55	11,900 (70)	9,770 (73)	8,470 (75.5)	6,060 (73)		
60	11,000 (68)	9,020 (71)	7,920 (73.5)	6,060 (71)	*6,040 (78)	
65	10,000 (66)	8,360 (69.5)	7,430 (72)	6,060 (69.5)	5,900 (75)	
70	9,190 (64)	7,780 (67.5)	6,980 (70)	6,060 (68)	5,730 (73.5)	*4,930 (78)
75	8,460 (62)	7,260 (65.5)	6,580 (68)	6,060 (66)	5,330 (71.5)	4,640 (76)
80	7,820 (60)	6,790 (63.5)	6,210 (65.5)	6,040 (64.5)	4,980 (70)	4,370 (74)
85	7,250 (58)	6,370 (61)	5,870 (63.5)	5,570 (63)	4,650 (68)	4,120 (72)
90	6,570 (55.5)	5,990 (59)	5,560 (61)	5,150 (61)	4,360 (66.5)	3,890 (70)
95	5,710 (53.5)	5,640 (56.5)	5,280 (59)	4,780 (59.5)	4,090 (64.5)	3,680 (68.5)
100	4,940 (51)	5,320 (54.5)	5,020 (56.5)	4,440 (57.5)	3,840 (62.5)	3,480 (66.5)
105	4,250 (48.5)	4,750 (52)	4,770 (54)	4,130 (55.5)	3,610 (60.5)	3,300 (64.5)
110	3,630 (46)	4,070 (49.5)	4,410 (51)	3,850 (53.5)	3,400 (58.5)	3,130 (62.5)
115	3,070 (43.5)	3,460 (46.5)	3,760 (48.5)	3,550 (52)	3,200 (56.5)	2,970 (60)
120	2,550 (40.5)	2,900 (44)	3,170 (45)	3,060 (49.5)	3,020 (54.5)	2,820 (58)
125	2,080 (37.5)	2,390 (41)		2,610 (47.5)	2,840 (52.5)	2,680 (55.5)
130	1,650 (34)	1,920 (37.5)		2,200 (45.5)	2,690 (50)	2,540 (53)
135	1,250 (30.5)	1,480 (34)		1,820 (43)	2,370 (48)	2,420 (50.5)
140		1,080 (29.5)		1,470 (40.5)	1,950 (45)	2,220 (47.5)
145				1,150 (38)	1,570 (42.5)	
150					1,210 (39.5)	
Minimum boom angle (°) for indicated length (no load)	26.5	28.5	43.5	35	36	46
Maximum boom length (ft.) at 0° boom angle (no load)		110			90	

NOTE: () Boom angles are in degrees. A6-829-103772
 #LMI operating code. Refer to LMI manual for operating instructions.
 *This capacity is based upon maximum boom angle.

NOTES:

1. All capacities above the bold line are based on structural strength of boom extension and do not exceed 85% of tipping loads, in accordance with SAE J-765.
2. The 33 ft. extension length may be used with single or double part line lifting service. The 56 ft. extension length may be used for single line lifting service only.
3. For main boom lengths less than 128 ft. with the boom extension erected, the rated loads are determined by boom angle. Use only the column which corresponds to the boom extension length and offset for which the machine is set up. For boom angles not shown, use rating of the next lower boom angle.
4. **WARNING:** Operation of this machine with heavier loads than the capacities listed is strictly prohibited. Machine tipping with boom extension occurs rapidly and without advance warning.
5. Boom angle is the angle above or below horizontal of the longitudinal axis of the boom base section after lifting rated load.
6. Capacities listed are with outriggers properly extended and vertical jacks set only.
7. When lifting over the main boom nose with 33 ft. or 56 ft. extension erected, the outriggers must be fully extended or 50% extended (15 ft. 5 in. spread).

TMS800E

GROVE

THIS CHART IS ONLY A GUIDE AND SHOULD NOT BE USED TO OPERATE THE CRANE. The individual crane's load chart, operating instructions and other instructional plates must be read and understood prior to operating the crane.

load charts

17

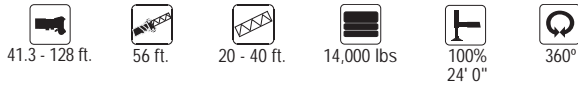

Pounds						
Feet	76 ft. (56 ft. LENGTH + 1 INSERT)			96 ft. (56 ft. LENGTH + 2 INSERTS)		
	0° OFFSET	20° OFFSET	40° OFFSET	0° OFFSET	20° OFFSET	40° OFFSET
50	4,850 (77.5)					
55	4,850 (76)			3,520 (78)		
60	4,850 (74.5)			3,520 (77)		
65	4,850 (73)	*5,290 (78)		3,520 (75.5)		
70	4,850 (71.5)	4,860 (76.5)		3,520 (74)		
75	4,850 (70)	4,470 (75)		3,520 (72.5)	3,740 (77)	
80	4,730 (68.5)	4,110 (73.5)	4,050 (77)	3,520 (71.5)	3,420 (75.5)	
85	4,310 (67)	3,790 (72)	3,500 (75.5)	3,300 (70)	3,100 (74.5)	*3,250 (78)
90	3,940 (65.5)	3,500 (70)	3,260 (73.5)	2,970 (68.5)	2,820 (73)	2,720 (76)
95	3,610 (63.5)	3,240 (68.5)	3,030 (72)	2,660 (67)	2,560 (71.5)	2,490 (74.5)
100	3,310 (62)	3,000 (67)	2,830 (70.5)	2,390 (65.5)	2,320 (70)	2,270 (73)
105	3,040 (60.5)	2,770 (65)	2,630 (68.5)	2,140 (64)	2,100 (68.5)	2,070 (71.5)
110	2,790 (59)	2,570 (63.5)	2,450 (66.5)	1,920 (62.5)	1,900 (67)	1,890 (70)
115	2,560 (57)	2,370 (61.5)	2,280 (65)	1,710 (61)	1,710 (65.5)	1,710 (68.5)
120	2,350 (55.5)	2,200 (60)	2,120 (63)	1,520 (59.5)	1,540 (64)	1,550 (66.5)
125	2,160 (53.5)	2,030 (58)	1,970 (61)	1,350 (58)	1,380 (62.5)	1,390 (65)
130	1,990 (52)	1,880 (56.5)	1,830 (59)	1,190 (56.5)	1,230 (60.5)	1,250 (63.5)
135	1,820 (50)	1,730 (54.5)	1,700 (57)	1,040 (55)	1,080 (59)	1,110 (61.5)
140	1,600 (48)	1,590 (52.5)	1,570 (55)			
145	1,260 (46)	1,470 (50.5)	1,450 (52.5)			
150		1,340 (48)	1,340 (50.5)			
155		1,100 (46)	1,230 (48)			
160			1,020 (45)			
Minimum boom angle (°) for indicated length (no load)	43.5	44.5	44	53.5	58	60.5
Maximum boom length (ft.) at 0° boom angle (no load)		70			60	

NOTE: () Boom angles are in degrees. #LMI operating code. Refer to LMI manual for operating instructions. *This capacity is based upon maximum boom angle. A6-829-103786

NOTES:

- All capacities above the bold line are based on structural strength of boom extension and do not exceed 85% of tipping loads, in accordance with SAE J-765.
- The 56 ft. extension length may be used for single line lifting service only.
- For main boom lengths less than 128 ft. with the boom extension erected, the rated loads are determined by boom angle. Use only the column which corresponds to the boom extension length and offset for which the machine is set up. For boom angles not shown, use rating of the next lower boom angle.
- WARNING:** Operation of this machine with heavier loads than the capacities listed is strictly prohibited. Machine tipping with boom extension occurs rapidly and without advance warning.
- Boom angle is the angle above or below horizontal of the longitudinal axis of the boom base section after lifting rated load.
- Capacities listed are with outriggers properly extended and vertical jacks set only.
- When lifting over the main boom nose with 56 ft. extension erected and inserts, the outriggers must be fully extended and vertical jacks set.

TMS800E

load charts

18

41.3 - 128 ft.
 12,000 lbs
 100% 24' 0"
 360°

Feet	Main Boom Length in Feet										
	41.3	50	60	**70	80	90	100	110	120	128	
8	++150,000 (73)										
9	++150,000 (71.5)										
10	145,000 (70)	86,000 (74)	86,000 (77)								
12	128,500 (67)	86,000 (71.5)	86,000 (75)	41,000 (77)							
15	110,000 (62)	86,000 (67.5)	86,000 (71.5)	41,000 (74.5)	39,000 (76.5)						
20	83,950 (53.5)	83,650 (61)	83,450 (66.5)	41,000 (70)	39,000 (73)	38,800 (75)	*38,700 (78)	*31,950 (78)			
25	56,850 (44)	56,900 (54)	56,450 (61)	41,000 (65.5)	39,000 (69)	38,800 (71.5)	38,700 (74)	31,950 (75.5)	*25,750 (78)	*14,600 (78)	
30	40,200 (31)	40,400 (46.5)	40,350 (55.5)	40,050 (61)	39,000 (65)	38,800 (68.5)	36,150 (70.5)	31,950 (72.5)	25,750 (74.5)	14,600 (75.5)	
35	30,200 (37)		30,350 (49.5)	30,250 (56.5)	31,200 (61)	32,200 (65)	31,350 (67.5)	29,300 (70)	25,750 (72)	14,600 (73)	
40	23,250 (24)		23,450 (42)	23,550 (51)	24,500 (57)	25,400 (61)	26,450 (64.5)	25,650 (67.5)	23,900 (69.5)	14,600 (71)	
45	18,500 (21.5)		18,650 (33.5)	18,650 (45.5)	19,600 (52.5)	20,450 (57.5)	21,300 (61.5)	21,650 (64.5)	21,450 (67)	14,600 (68.5)	
50	14,750 (21.5)		14,950 (39)	15,850 (47.5)	16,750 (53.5)	17,500 (58)	17,850 (61.5)	18,200 (64.5)	18,200 (66)	14,600 (66)	
55	12,000 (31.5)		12,900 (42.5)	12,900 (49.5)	13,750 (54.5)	14,550 (58.5)	14,900 (62)	15,300 (66)	15,300 (64)	14,600 (64)	
60	9,680 (20.5)		10,500 (36.5)	11,350 (45)	12,200 (51)	12,550 (55.5)	12,950 (59)	13,450 (61.5)	13,450 (61.5)	13,450 (61.5)	
65	8,580 (29)		9,400 (40)	10,250 (47)	10,650 (52)	11,050 (56)	11,450 (59)	11,450 (59)	11,450 (59)	11,450 (59)	
70	6,950 (18.5)		7,750 (34)	8,620 (42.5)	9,050 (48.5)	9,460 (53)	9,810 (56)	9,810 (56)	9,810 (56)	9,810 (56)	
75	6,350 (27.5)		7,230 (38)	7,660 (45)	8,080 (50)	8,430 (53.5)	8,430 (53.5)	8,430 (53.5)	8,430 (53.5)	8,430 (53.5)	
80	5,140 (17.5)		6,040 (32.5)	6,460 (41)	6,880 (47)	7,240 (50.5)	7,240 (50.5)	7,240 (50.5)	7,240 (50.5)	7,240 (50.5)	
85	5,010 (26)		5,430 (36.5)	5,840 (43)	6,220 (47.5)	6,220 (47.5)	6,220 (47.5)	6,220 (47.5)	6,220 (47.5)	6,220 (47.5)	
90	4,110 (17)		4,520 (31)	4,930 (39.5)	5,320 (44)	5,320 (44)	5,320 (44)	5,320 (44)	5,320 (44)	5,320 (44)	
95	3,730 (25)		4,120 (35)	4,510 (40.5)	4,810 (45.5)	5,110 (50.5)	5,110 (50.5)	5,110 (50.5)	5,110 (50.5)	5,110 (50.5)	
100	3,020 (16)		3,410 (30)	3,790 (36.5)	4,170 (42.5)	4,550 (48.5)	4,550 (48.5)	4,550 (48.5)	4,550 (48.5)	4,550 (48.5)	
105	2,770 (24)		3,140 (32)	3,510 (38)	3,880 (44)	4,250 (50)	4,250 (50)	4,250 (50)	4,250 (50)	4,250 (50)	
110	2,190 (16)		2,560 (27)	2,930 (33)	3,300 (39)	3,670 (45)	3,670 (45)	3,670 (45)	3,670 (45)	3,670 (45)	
115	2,040 (21)		2,410 (27)	2,780 (33)	3,150 (39)	3,520 (45)	3,520 (45)	3,520 (45)	3,520 (45)	3,520 (45)	
120	1,570 (10)		1,940 (16)	2,310 (22)	2,680 (28)	3,050 (34)	3,050 (34)	3,050 (34)	3,050 (34)	3,050 (34)	

Minimum boom angle (deg.) for indicated length (no load) 9
 Maximum boom length (ft.) at 0 deg. boom angle (no load) 120
 #LMI operating code. Refer to LMI manual for instructions.
 *This capacity is based upon maximum obtainable boom angle.
 Note: () Boom angles are in degrees.

Boom Angle	Lifting Capacities at Zero Degree Boom Angle										
	Main Boom Length in Feet										
	41.3	50	60	**70	80	90	100	110	120		
0°	20,750 (34.1)	15,150 (42.8)	10,500 (52.8)	6,700 (63)	5,100 (72.8)	3,900 (82.8)	2,900 (92.8)	2,000 (102.8)	1,300 (112.8)		

Note: () Reference radii in feet. A6-829-103751
 **This boom length is with inner-mid fully extended and outer-mid & fly fully retracted.

TMS800E

load charts

19



Pounds						
Feet	33 ft. LENGTH			56 ft. LENGTH		
	0° OFFSET	20° OFFSET	40° OFFSET	0° OFFSET	20° OFFSET	40° OFFSET
35	*11,900 (78)					
40	11,900 (75.5)			6,060 (77.5)		
45	11,900 (73.5)	*11,600 (78)		6,060 (76)		
50	11,900 (71.5)	10,600 (75)	*9,700 (78)	6,060 (74.5)		
55	11,900 (70)	9,770 (73)	8,470 (75.5)	6,060 (73)		
60	11,000 (68)	9,020 (71)	7,920 (73.5)	6,060 (71)	*6,040 (78)	
65	10,000 (66)	8,360 (69.5)	7,430 (72)	6,060 (69.5)	5,900 (75)	
70	9,190 (64)	7,780 (67.5)	6,980 (70)	6,060 (68)	5,730 (73.5)	*4,930 (78)
75	8,460 (62)	7,260 (65.5)	6,580 (68)	6,060 (66)	5,330 (71.5)	4,640 (76)
80	7,820 (60)	6,790 (63.5)	6,210 (65.5)	6,040 (64.5)	4,980 (70)	4,370 (74)
85	7,070 (58)	6,370 (61)	5,870 (63.5)	5,570 (63)	4,650 (68)	4,120 (72)
90	6,120 (55.5)	5,990 (59)	5,560 (61)	5,150 (61)	4,360 (66.5)	3,890 (70)
95	5,280 (53.5)	5,640 (56.5)	5,280 (59)	4,780 (59.5)	4,090 (64.5)	3,680 (68.5)
100	4,540 (51)	5,100 (54.5)	5,020 (56.5)	4,440 (57.5)	3,840 (62.5)	3,480 (66.5)
105	3,870 (48.5)	4,360 (52)	4,750 (54)	4,130 (55.5)	3,610 (60.5)	3,300 (64.5)
110	3,270 (46)	3,710 (49.5)	4,050 (51)	3,720 (53.5)	3,400 (58.5)	3,130 (62.5)
115	2,720 (43.5)	3,110 (46.5)	3,420 (48.5)	3,200 (52)	3,200 (56.5)	2,970 (60)
120	2,220 (40.5)	2,570 (44)	2,840 (45)	2,730 (49.5)	3,020 (54.5)	2,820 (58)
125	1,760 (37.5)	2,070 (41)		2,290 (47.5)	2,840 (52.5)	2,680 (55.5)
130	1,340 (34)	1,610 (37.5)		1,900 (45.5)	2,510 (50)	2,540 (53)
135		1,190 (34)		1,530 (43)	2,070 (48)	2,410 (50.5)
140				1,190 (40.5)	1,670 (45)	1,940 (47.5)
145					1,300 (42.5)	
Minimum boom angle (°) for indicated length (no load)	30.5	32.5	43.5	38	39.5	46
Maximum boom length (ft.) at 0° boom angle (no load)		100				90

NOTE: () Boom angles are in degrees.
 #LMI operating code. Refer to LMI manual for operating instructions. A6-829-103773
 *This capacity is based upon maximum boom angle.

NOTES:

1. All capacities above the bold line are based on structural strength of boom extension and do not exceed 85% of tipping loads, in accordance with SAE J-765.
2. The 33 ft. extension length may be used with single or double part line lifting service. The 56 ft. extension length may be used for single line lifting service only.
3. For main boom lengths less than 128 ft. with the boom extension erected, the rated loads are determined by boom angle. Use only the column which corresponds to the boom extension length and offset for which the machine is set up. For boom angles not shown, use rating of the next lower boom angle.
4. **WARNING:** Operation of this machine with heavier loads than the capacities listed is strictly prohibited. Machine tipping with boom extension occurs rapidly and without advance warning.
5. Boom angle is the angle above or below horizontal of the longitudinal axis of the boom base section after lifting rated load.
6. Capacities listed are with outriggers properly extended and vertical jacks set only.
7. When lifting over the main boom nose with 33 ft. or 56 ft. extension erected, the outriggers must be fully extended or 50% extended (15 ft. 5 in. spread).

TMS800E

load charts

20

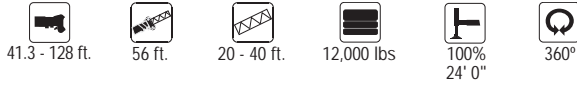

Feet	Pounds					
	76 ft. (56 ft. LENGTH + 1 INSERT)			96 ft. (56 ft. LENGTH + 2 INSERTS)		
	0° OFFSET	20° OFFSET	40° OFFSET	0° OFFSET	20° OFFSET	40° OFFSET
50	4,850 (77.5)					
55	4,850 (76)			3,520 (78)		
60	4,850 (74.5)			3,520 (77)		
65	4,850 (73)	*5,290 (78)		3,520 (75.5)		
70	4,850 (71.5)	4,860 (76.5)		3,520 (74)		
75	4,850 (70)	4,470 (75)		3,520 (72.5)	3,740 (77)	
80	4,730 (68.5)	4,110 (73.5)	4,050 (77)	3,520 (71.5)	3,420 (75.5)	
85	4,310 (67)	3,790 (72)	3,500 (75.5)	3,300 (70)	3,100 (74.5)	*3,250 (78)
90	3,940 (65.5)	3,500 (70)	3,260 (73.5)	2,970 (68.5)	2,820 (73)	2,720 (76)
95	3,610 (63.5)	3,240 (68.5)	3,030 (72)	2,660 (67)	2,560 (71.5)	2,490 (74.5)
100	3,310 (62)	3,000 (67)	2,830 (70.5)	2,390 (65.5)	2,320 (70)	2,270 (73)
105	3,040 (60.5)	2,770 (65)	2,630 (68.5)	2,140 (64)	2,100 (68.5)	2,070 (71.5)
110	2,790 (59)	2,570 (63.5)	2,450 (66.5)	1,920 (62.5)	1,900 (67)	1,890 (70)
115	2,560 (57)	2,370 (61.5)	2,280 (65)	1,710 (61)	1,710 (65.5)	1,710 (68.5)
120	2,350 (55.5)	2,200 (60)	2,120 (63)	1,520 (59.5)	1,540 (64)	1,550 (66.5)
125	2,160 (53.5)	2,030 (58)	1,970 (61)	1,350 (58)	1,380 (62.5)	1,390 (65)
130	1,990 (52)	1,880 (56.5)	1,830 (59)	1,190 (56.5)	1,230 (60.5)	1,250 (63.5)
135	1,670 (50)	1,730 (54.5)	1,700 (57)	1,040 (55)	1,080 (59)	1,110 (61.5)
140	1,320 (48)	1,590 (52.5)	1,570 (55)			
145		1,470 (50.5)	1,450 (52.5)			
150		1,170 (48)	1,340 (50.5)			
155			1,100 (48)			

Minimum boom angle (°) for indicated length (no load)	46	46	46.5	53.5	58	60.5
Maximum boom length (ft.) at 0° boom angle (no load)		70			60	

NOTE: () Boom angles are in degrees.
 #LMI operating code. Refer to LMI manual for operating instructions.
 *This capacity is based upon maximum boom angle.

NOTES:

1. All capacities above the bold line are based on structural strength of boom extension and do not exceed 85% of tipping loads, in accordance with SAE J-765.
2. The 56 ft. extension length may be used for single line lifting service only.
3. For main boom lengths less than 128 ft. with the boom extension erected, the rated loads are determined by boom angle. Use only the column which corresponds to the boom extension length and offset for which the machine is set up. For boom angles not shown, use rating of the next lower boom angle.
4. **WARNING:** Operation of this machine with heavier loads than the capacities listed is strictly prohibited. Machine tipping with boom extension occurs rapidly and without advance warning.
5. Boom angle is the angle above or below horizontal of the longitudinal axis of the boom base section after lifting rated load.
6. Capacities listed are with outriggers properly extended and vertical jacks set only.
7. When lifting over the main boom nose with 56 ft. extension erected and inserts, the outriggers must be fully extended and vertical jacks set.

TMS800E

GROVE

THIS CHART IS ONLY A GUIDE AND SHOULD NOT BE USED TO OPERATE THE CRANE. The individual crane's load chart, operating instructions and other instructional plates must be read and understood prior to operating the crane.

load charts



Feet	Main Boom Length in Feet										
	41.3	50	60	**70	80	90	100	110	120	128	
8	++150,000 (73)										
9	++150,000 (71.5) 86,000 (75)										
10	144,500 (70) 86,000 (74) 86,000 (77)										
12	128,000 (67) 86,000 (71.5) 86,000 (75) 41,000 (77)										
15	109,500 (62) 86,000 (67.5) 86,000 (71.5) 41,000 (74.5) 39,000 (76.5)										
20	82,700 (53.5) 82,400 (61) 82,200 (66.5) 41,000 (70) 39,000 (73) 38,800 (75) *38,700 (78) *31,950 (78)										
25	54,550 (44) 54,600 (54) 54,150 (61) 41,000 (65.5) 39,000 (69) 38,800 (71.5) 38,700 (74) 31,950 (75.5) *25,750 (78) **14,600 (78)										
30	38,450 (31) 38,650 (46.5) 38,600 (55.5) 38,300 (61) 39,000 (65) 38,800 (68.5) 36,150 (70.5) 31,950 (72.5) 25,750 (74.5) 14,600 (75.5)										
35	28,800 (37) 28,950 (49.5) 28,850 (56.5) 29,800 (61) 30,750 (65) 31,350 (67.5) 29,300 (70) 25,750 (72) 14,600 (73)										
40	22,100 (24) 22,300 (42) 22,400 (51) 23,300 (57) 24,200 (61) 25,250 (64.5) 25,500 (67.5) 23,900 (69.5) 14,600 (71)										
45	17,500 (33.5) 17,650 (45.5) 18,600 (52.5) 19,450 (57.5) 20,300 (61.5) 20,600 (64.5) 20,900 (67) 14,600 (68.5)										
50	13,850 (21.5) 14,050 (39) 14,950 (47.5) 15,850 (53.5) 16,600 (58) 16,950 (61.5) 17,300 (64.5) 14,600 (66)										
55	11,200 (31.5) 12,100 (42.5) 12,950 (49.5) 13,750 (54.5) 14,100 (58.5) 14,500 (62) 14,600 (64)										
60	8,960 (20.5) 9,810 (36.5) 10,650 (45) 11,450 (51) 11,850 (55.5) 12,250 (59) 12,700 (61.5)										
65	7,930 (29) 8,740 (40) 9,610 (47) 10,000 (52) 10,400 (56) 10,800 (59)										
70	6,350 (18.5) 7,140 (34) 8,020 (42.5) 8,450 (48.5) 8,850 (53) 9,210 (56)										
75	5,790 (27.5) 6,670 (38) 7,100 (45) 7,520 (50) 7,870 (53.5)										
80	4,620 (17.5) 5,520 (32.5) 5,950 (41) 6,360 (47) 6,720 (50.5)										
85	4,520 (26) 4,940 (36.5) 5,350 (43) 5,730 (47.5)										
90	3,650 (17) 4,070 (31) 4,470 (39.5) 4,870 (44)										
95	3,300 (25) 3,700 (35) 4,080 (40.5)										
100	2,610 (16) 3,000 (30) 3,380 (36.5)										
105	2,390 (24) 2,760 (32)										
110	1,830 (16) 2,200 (27)										
115	1,700 (21)										
120	1,240 (10)										

Minimum boom angle (deg.) for indicated length (no load) 9
 Maximum boom length (ft.) at 0 deg. boom angle (no load) 120

#LMI operating code. Refer to LMI manual for instructions.
 *This capacity is based upon maximum obtainable boom angle.
 Note: () Boom angles are in degrees.
 ++9 parts of line required to lift this capacity (using aux. boom nose). Refer to Operator's & Safety Handbook for reeving diagram.

Lifting Capacities at Zero Degree Boom Angle											
Boom Angle	Main Boom Length in Feet										
	41.3	50	60	**70	80	90	100	110	120		
0°	20,750 (34.1)	15,150 (42.8)	10,500 (52.8)	6,700 (63)	5,100 (72.8)	3,900 (82.8)	2,900 (92.8)	2,000 (102.8)	1,300 (112.8)		

Note: () Reference radii in feet.
 **This boom length is with inner-mid fully extended and outer-mid & fly fully retracted.

load charts

22



Pounds						
Feet	33 ft. LENGTH			56 ft. LENGTH		
	0° OFFSET	20° OFFSET	40° OFFSET	0° OFFSET	20° OFFSET	40° OFFSET
35	*11,900 (78)					
40	11,900 (75.5)			6,060 (77.5)		
45	11,900 (73.5)	*11,600 (78)		6,060 (76)		
50	11,900 (71.5)	10,600 (75)	*9,700 (78)	6,060 (74.5)		
55	11,900 (70)	9,770 (73)	8,470 (75.5)	6,060 (73)		
60	11,000 (68)	9,020 (71)	7,920 (73.5)	6,060 (71)	*6,040 (78)	
65	10,000 (66)	8,360 (69.5)	7,430 (72)	6,060 (69.5)	5,900 (75)	
70	9,190 (64)	7,780 (67.5)	6,980 (70)	6,060 (68)	5,730 (73.5)	*4,930 (78)
75	8,460 (62)	7,260 (65.5)	6,580 (68)	6,060 (66)	5,330 (71.5)	4,640 (76)
80	7,630 (60)	6,790 (63.5)	6,210 (65.5)	6,040 (64.5)	4,980 (70)	4,370 (74)
85	6,590 (58)	6,370 (61)	5,870 (63.5)	5,570 (63)	4,650 (68)	4,120 (72)
90	5,670 (55.5)	5,990 (59)	5,560 (61)	5,150 (61)	4,360 (66.5)	3,890 (70)
95	4,850 (53.5)	5,480 (56.5)	5,280 (59)	4,780 (59.5)	4,090 (64.5)	3,680 (68.5)
100	4,130 (51)	4,690 (54.5)	5,020 (56.5)	4,440 (57.5)	3,840 (62.5)	3,480 (66.5)
105	3,480 (48.5)	3,980 (52)	4,360 (54)	3,910 (55.5)	3,610 (60.5)	3,300 (64.5)
110	2,900 (46)	3,340 (49.5)	3,690 (51)	3,350 (53.5)	3,400 (58.5)	3,130 (62.5)
115	2,370 (43.5)	2,760 (46.5)	3,070 (48.5)	2,850 (52)	3,200 (56.5)	2,970 (60)
120	1,890 (40.5)	2,240 (44)	2,510 (45)	2,390 (49.5)	3,020 (54.5)	2,820 (58)
125	1,450 (37.5)	1,760 (41)		1,970 (47.5)	2,670 (52.5)	2,680 (55.5)
130	1,040 (34)	1,310 (37.5)		1,590 (45.5)	2,210 (50)	2,540 (53)
135				1,240 (43)	1,780 (48)	2,110 (50.5)
140					1,390 (45)	1,660 (47.5)
145					1,030 (42.5)	
Minimum boom angle (°) for indicated length (no load)	33	34	43.5	40.5	41.5	46
Maximum boom length (ft.) at 0° boom angle (no load)		100				80

NOTE: () Boom angles are in degrees. A6-829-103774
 #LMI operating code. Refer to LMI manual for operating instructions.
 *This capacity is based upon maximum boom angle.

NOTES:

1. All capacities above the bold line are based on structural strength of boom extension and do not exceed 85% of tipping loads, in accordance with SAE J-765.
2. The 33 ft. extension length may be used with single or double part line lifting service. The 56 ft. extension length may be used for single line lifting service only.
3. For main boom lengths less than 128 ft. with the boom extension erected, the rated loads are determined by boom angle. Use only the column which corresponds to the boom extension length and offset for which the machine is set up. For boom angles not shown, use rating of the next lower boom angle.
4. **WARNING:** Operation of this machine with heavier loads than the capacities listed is strictly prohibited. Machine tipping with boom extension occurs rapidly and without advance warning.
5. Boom angle is the angle above or below horizontal of the longitudinal axis of the boom base section after lifting rated load.
6. Capacities listed are with outriggers properly extended and vertical jacks set only.
7. When lifting over the main boom nose with 33 ft. or 56 ft. extension erected, the outriggers must be fully extended or 50% extended (15 ft. 5 in. spread).

TMS800E

GROVE

THIS CHART IS ONLY A GUIDE AND SHOULD NOT BE USED TO OPERATE THE CRANE. The individual crane's load chart, operating instructions and other instructional plates must be read and understood prior to operating the crane.

load charts

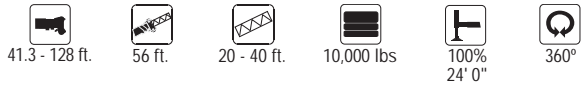

Feet	Pounds					
	76 ft. (56 ft. LENGTH + 1 INSERT)			96 ft. (56 ft. LENGTH + 2 INSERTS)		
	0° OFFSET	20° OFFSET	40° OFFSET	0° OFFSET	20° OFFSET	40° OFFSET
50	4,850 (77.5)					
55	4,850 (76)			3,520 (78)		
60	4,850 (74.5)			3,520 (77)		
65	4,850 (73)	*5,290 (78)		3,520 (75.5)		
70	4,850 (71.5)	4,860 (76.5)		3,520 (74)		
75	4,850 (70)	4,470 (75)		3,520 (72.5)	3,740 (77)	
80	4,730 (68.5)	4,110 (73.5)	4,050 (77)	3,520 (71.5)	3,420 (75.5)	
85	4,310 (67)	3,790 (72)	3,500 (75.5)	3,300 (70)	3,100 (74.5)	*3,250 (78)
90	3,940 (65.5)	3,500 (70)	3,260 (73.5)	2,970 (68.5)	2,820 (73)	2,720 (76)
95	3,610 (63.5)	3,240 (68.5)	3,030 (72)	2,660 (67)	2,560 (71.5)	2,490 (74.5)
100	3,310 (62)	3,000 (67)	2,830 (70.5)	2,390 (65.5)	2,320 (70)	2,270 (73)
105	3,040 (60.5)	2,770 (65)	2,630 (68.5)	2,140 (64)	2,100 (68.5)	2,070 (71.5)
110	2,790 (59)	2,570 (63.5)	2,450 (66.5)	1,920 (62.5)	1,900 (67)	1,890 (70)
115	2,560 (57)	2,370 (61.5)	2,280 (65)	1,710 (61)	1,710 (65.5)	1,710 (68.5)
120	2,350 (55.5)	2,200 (60)	2,120 (63)	1,520 (59.5)	1,540 (64)	1,550 (66.5)
125	2,150 (53.5)	2,030 (58)	1,970 (61)	1,350 (58)	1,380 (62.5)	1,390 (65)
130	1,750 (52)	1,880 (56.5)	1,830 (59)	1,190 (56.5)	1,230 (60.5)	1,250 (63.5)
135	1,380 (50)	1,730 (54.5)	1,700 (57)	1,040 (55)	1,080 (59)	1,110 (61.5)
140	1,040 (48)	1,590 (52.5)	1,570 (55)			
145		1,240 (50.5)	1,450 (52.5)			
150			1,200 (50.5)			
Minimum boom angle (°) for indicated length (no load)	46.5	48	48	54	58	60.5
Maximum boom length (ft.) at 0° boom angle (no load)		70			60	

NOTE: () Boom angles are in degrees. A6-829-103788
 #LMI operating code. Refer to LMI manual for operating instructions.
 *This capacity is based upon maximum boom angle.

NOTES:

1. All capacities above the bold line are based on structural strength of boom extension and do not exceed 85% of tipping loads, in accordance with SAE J-765.
2. The 56 ft. extension length may be used for single line lifting service only.
3. For main boom lengths less than 128 ft. with the boom extension erected, the rated loads are determined by boom angle. Use only the column which corresponds to the boom extension length and offset for which the machine is set up. For boom angles not shown, use rating of the next lower boom angle.
4. **WARNING:** Operation of this machine with heavier loads than the capacities listed is strictly prohibited. Machine tipping with boom extension occurs rapidly and without advance warning.
5. Boom angle is the angle above or below horizontal of the longitudinal axis of the boom base section after lifting rated load.
6. Capacities listed are with outriggers properly extended and vertical jacks set only.
7. When lifting over the main boom nose with 56 ft. extension erected and inserts, the outriggers must be fully extended and vertical jacks set.

load charts

24

- 41.3 - 128 ft.
- 8,000 lbs
-
-

Feet	Main Boom Length in Feet									
	41.3	50	60	**70	80	90	100	110	120	128
8	++150,000 (73)									
9	++150,000 (71.5) 86,000 (75)									
10	143,500 (70)	86,000 (74)	86,000 (77)							
12	127,500 (67)	86,000 (71.5)	86,000 (75)	41,000 (77)						
15	109,000 (62)	86,000 (67.5)	86,000 (71.5)	41,000 (74.5)	39,000 (76.5)					
20	81,450 (53.5)	80,150 (61)	79,250 (66.5)	41,000 (70)	39,000 (73)	38,800 (75)	*38,700 (78)	*31,950 (78)		
25	52,250 (44)	52,300 (54)	51,850 (61)	41,000 (65.5)	39,000 (69)	38,800 (71.5)	38,700 (74)	31,950 (75.5)	*25,750 (78)	*14,600 (78)
30	36,700 (31)	36,900 (46.5)	36,850 (55.5)	36,600 (61)	37,650 (65)	38,700 (68.5)	36,150 (70.5)	31,950 (72.5)	25,750 (74.5)	14,600 (75.5)
35		27,400 (37)	27,500 (49.5)	27,450 (56.5)	28,400 (61)	29,350 (65)	30,850 (67.5)	29,300 (70)	25,750 (72)	14,600 (73)
40		20,900 (24)	21,100 (42)	21,200 (51)	22,100 (57)	23,000 (61)	24,050 (64.5)	24,300 (67.5)	23,900 (69.5)	14,600 (71)
45			16,450 (33.5)	16,600 (45.5)	17,600 (52.5)	18,400 (57.5)	19,300 (61.5)	19,600 (64.5)	19,900 (67)	14,600 (68.5)
50			12,950 (21.5)	13,150 (39)	14,050 (47.5)	14,950 (53.5)	15,700 (58)	16,050 (61.5)	16,400 (64.5)	14,600 (66)
55				10,400 (31.5)	11,300 (42.5)	12,150 (49.5)	12,950 (54.5)	13,300 (58.5)	13,700 (62)	14,300 (64)
60				8,240 (20.5)	9,100 (36.5)	9,930 (45)	10,750 (51)	11,150 (55.5)	11,500 (59)	12,000 (61.5)
65					7,270 (29)	8,090 (40)	8,960 (47)	9,360 (52)	9,740 (56)	10,150 (59)
70					5,750 (18.5)	6,540 (34)	7,420 (42.5)	7,850 (48.5)	8,250 (53)	8,610 (56)
75						5,230 (27.5)	6,120 (38)	6,550 (45)	6,960 (50)	7,310 (53.5)
80						4,100 (17.5)	5,000 (32.5)	5,430 (41)	5,840 (47)	6,210 (50.5)
85							4,040 (26)	4,460 (36.5)	4,870 (43)	5,250 (47.5)
90							3,200 (17)	3,620 (31)	4,020 (39.5)	4,420 (44)
95								2,870 (25)	3,270 (35)	3,660 (40.5)
100								2,210 (16)	2,600 (30)	2,980 (36.5)
105									2,000 (24)	2,380 (32)
110									1,470 (16)	1,840 (27)
115										1,350 (21)

Minimum boom angle (deg.) for indicated length (no load) 9
 Maximum boom length (ft.) at 0 deg. boom angle (no load) 102

#LMI operating code. Refer to LMI manual for instructions.

*This capacity is based upon maximum obtainable boom angle.

Note: () Boom angles are in degrees.

++9 parts of line required to lift this capacity (using aux. boom nose). Refer to Operator's & Safety Handbook for reeving diagram.

Boom Angle	Lifting Capacities at Zero Degree Boom Angle									
	Main Boom Length in Feet									
	41.3	50	60	**70	80	90	100	110	120	
0°	20,750 (34.1)	15,150 (42.8)	10,500 (52.8)	6,700 (63)	5,000 (72.8)	3,540 (82.8)	2,780 (92.8)	1,870 (102.8)	1,190 (112.8)	

Note: () Reference radii in feet.

**This boom length is with inner-mid fully extended and outer-mid & fly fully retracted.

A6-829-103753

TMS800E

load charts

25



Pounds						
Feet	33 ft. LENGTH			56 ft. LENGTH		
	0° OFFSET	20° OFFSET	40° OFFSET	0° OFFSET	20° OFFSET	40° OFFSET
35	*11,900 (78)					
40	11,900 (75.5)			6,060 (77.5)		
45	11,900 (73.5)	*11,600 (78)		6,060 (76)		
50	11,900 (71.5)	10,600 (75)	*9,700 (78)	6,060 (74.5)		
55	11,900 (70)	9,770 (73)	8,470 (75.5)	6,060 (73)		
60	11,000 (68)	9,020 (71)	7,920 (73.5)	6,060 (71)	*6,040 (78)	
65	10,000 (66)	8,360 (69.5)	7,430 (72)	6,060 (69.5)	5,900 (75)	
70	9,190 (64)	7,780 (67.5)	6,980 (70)	6,060 (68)	5,730 (73.5)	*4,930 (78)
75	8,280 (62)	7,260 (65.5)	6,580 (68)	6,060 (66)	5,330 (71.5)	4,640 (76)
80	7,120 (60)	6,790 (63.5)	6,210 (65.5)	6,040 (64.5)	4,980 (70)	4,370 (74)
85	6,100 (58)	6,370 (61)	5,870 (63.5)	5,570 (63)	4,650 (68)	4,120 (72)
90	5,210 (55.5)	5,920 (59)	5,560 (61)	5,150 (61)	4,360 (66.5)	3,890 (70)
95	4,430 (53.5)	5,050 (56.5)	5,280 (59)	4,780 (59.5)	4,090 (64.5)	3,680 (68.5)
100	3,730 (51)	4,290 (54.5)	4,720 (56.5)	4,120 (57.5)	3,840 (62.5)	3,480 (66.5)
105	3,100 (48.5)	3,600 (52)	3,980 (54)	3,530 (55.5)	3,610 (60.5)	3,300 (64.5)
110	2,540 (46)	2,980 (49.5)	3,320 (51)	2,990 (53.5)	3,400 (58.5)	3,130 (62.5)
115	2,030 (43.5)	2,420 (46.5)	2,720 (48.5)	2,510 (52)	3,200 (56.5)	2,970 (60)
120	1,560 (40.5)	1,910 (44)	2,180 (45)	2,060 (49.5)	2,840 (54.5)	2,820 (58)
125	1,130 (37.5)	1,440 (41)		1,660 (47.5)	2,350 (52.5)	2,680 (55.5)
130		1,010 (37.5)		1,290 (45.5)	1,900 (50)	2,310 (53)
135					1,490 (48)	1,820 (50.5)
140					1,110 (45)	1,380 (47.5)
Minimum boom angle (°) for indicated length (no load)	36.5	36.5	43.5	43	44	46
Maximum boom length (ft.) at 0° boom angle (no load)		90			80	

NOTE: () Boom angles are in degrees. #LMI operating code. Refer to LMI manual for operating instructions. *This capacity is based upon maximum boom angle. A6-829-103775

NOTES:

1. All capacities above the bold line are based on structural strength of boom extension and do not exceed 85% of tipping loads, in accordance with SAE J-765.
2. The 33 ft. extension length may be used with single or double part line lifting service. The 56 ft. extension length may be used for single line lifting service only.
3. For main boom lengths less than 128 ft. with the boom extension erected, the rated loads are determined by boom angle. Use only the column which corresponds to the boom extension length and offset for which the machine is set up. For boom angles not shown, use rating of the next lower boom angle.
4. **WARNING:** Operation of this machine with heavier loads than the capacities listed is strictly prohibited. Machine tipping with boom extension occurs rapidly and without advance warning.
5. Boom angle is the angle above or below horizontal of the longitudinal axis of the boom base section after lifting rated load.
6. Capacities listed are with outriggers properly extended and vertical jacks set only.
7. When lifting over the main boom nose with 33 ft. or 56 ft. extension erected, the outriggers must be fully extended or 50% extended (15 ft. 5 in. spread).

TMS800E

load charts

26

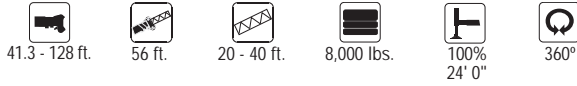

Feet	Pounds					
	76 ft. (56 ft. LENGTH + 1 INSERT)			96 ft. (56 ft. LENGTH + 2 INSERTS)		
	0° OFFSET	20° OFFSET	40° OFFSET	0° OFFSET	20° OFFSET	40° OFFSET
50	4,850 (77.5)					
55	4,850 (76)			3,520 (78)		
60	4,850 (74.5)			3,520 (77)		
65	4,850 (73)	*5,290 (78)		3,520 (75.5)		
70	4,850 (71.5)	4,860 (76.5)		3,520 (74)		
75	4,850 (70)	4,470 (75)		3,520 (72.5)	3,740 (77)	
80	4,730 (68.5)	4,110 (73.5)	4,050 (77)	3,520 (71.5)	3,420 (75.5)	
85	4,310 (67)	3,790 (72)	3,500 (75.5)	3,300 (70)	3,100 (74.5)	*3,250 (78)
90	3,940 (65.5)	3,500 (70)	3,260 (73.5)	2,970 (68.5)	2,820 (73)	2,720 (76)
95	3,610 (63.5)	3,240 (68.5)	3,030 (72)	2,660 (67)	2,560 (71.5)	2,490 (74.5)
100	3,310 (62)	3,000 (67)	2,830 (70.5)	2,390 (65.5)	2,320 (70)	2,270 (73)
105	3,040 (60.5)	2,770 (65)	2,630 (68.5)	2,140 (64)	2,100 (68.5)	2,070 (71.5)
110	2,790 (59)	2,570 (63.5)	2,450 (66.5)	1,920 (62.5)	1,900 (67)	1,890 (70)
115	2,560 (57)	2,370 (61.5)	2,280 (65)	1,710 (61)	1,710 (65.5)	1,710 (68.5)
120	2,250 (55.5)	2,200 (60)	2,120 (63)	1,520 (59.5)	1,540 (64)	1,550 (66.5)
125	1,840 (53.5)	2,030 (58)	1,970 (61)	1,350 (58)	1,380 (62.5)	1,390 (65)
130	1,460 (52)	1,880 (56.5)	1,830 (59)	1,190 (56.5)	1,230 (60.5)	1,250 (63.5)
135	1,110 (50)	1,700 (54.5)	1,700 (57)		1,080 (59)	1,110 (61.5)
140		1,320 (52.5)	1,570 (55)			
145			1,300 (52.5)			
Minimum boom angle (°) for indicated length (no load)	48.5	50.5	50.5	55	58	60.5
Maximum boom length (ft.) at 0° boom angle (no load)		60			60	

NOTE: () Boom angles are in degrees. A6-829-103789
 #LMI operating code. Refer to LMI manual for operating instructions.
 *This capacity is based upon maximum boom angle.

NOTES:

1. All capacities above the bold line are based on structural strength of boom extension and do not exceed 85% of tipping loads, in accordance with SAE J-765.
2. The 56 ft. extension length may be used for single line lifting service only.
3. For main boom lengths less than 128 ft. with the boom extension erected, the rated loads are determined by boom angle. Use only the column which corresponds to the boom extension length and offset for which the machine is set up. For boom angles not shown, use rating of the next lower boom angle.
4. **WARNING:** Operation of this machine with heavier loads than the capacities listed is strictly prohibited. Machine tipping with boom extension occurs rapidly and without advance warning.
5. Boom angle is the angle above or below horizontal of the longitudinal axis of the boom base section after lifting rated load.
6. Capacities listed are with outriggers properly extended and vertical jacks set only.
7. When lifting over the main boom nose with 56 ft. extension erected and inserts, the outriggers must be fully extended and vertical jacks set.

TMS800E

GROVE

THIS CHART IS ONLY A GUIDE AND SHOULD NOT BE USED TO OPERATE THE CRANE. The individual crane's load chart, operating instructions and other instructional plates must be read and understood prior to operating the crane.

load charts

27



Feet	Main Boom Length in Feet									
	41.3	50	60	**70	80	90	100	110	120	128
8	++150,000 (73)									
9	++150,000 (71.5)									
10	142,500 (70)	86,000 (74)	86,000 (77)							
12	126,500 (67)	86,000 (71.5)	86,000 (77)	41,000 (77)						
15	108,000 (62)	86,000 (67.5)	86,000 (71.5)	41,000 (74.5)	39,000 (76.5)					
20	75,150 (53.5)	73,500 (61)	72,600 (66.5)	41,000 (70)	39,000 (73)	38,800 (75)	*38,700 (78)	*31,950 (78)		
25	47,700 (44)	47,750 (54)	47,300 (61)	41,000 (65.5)	39,000 (69)	38,800 (71.5)	38,700 (74)	31,950 (75.5)	*25,750 (78)	*14,600 (78)
30	33,200 (31)	33,400 (46.5)	33,400 (55.5)	33,100 (61)	34,150 (65)	35,250 (68.5)	36,150 (70.5)	31,950 (72.5)	25,750 (74.5)	14,600 (75.5)
35		24,550 (37)	24,700 (49.5)	24,650 (56.5)	25,550 (61)	26,550 (65)	28,050 (67.5)	28,100 (70)	25,750 (72)	14,600 (73)
40		18,550 (24)	18,750 (42)	18,850 (51)	19,750 (57)	20,650 (61)	21,700 (64.5)	21,950 (67.5)	22,150 (69.5)	14,600 (71)
45			14,450 (33.5)	14,550 (45.5)	15,550 (52.5)	16,400 (57.5)	17,250 (61.5)	17,550 (64.5)	17,850 (67)	14,600 (68.5)
50			11,150 (21.5)	11,350 (39)	12,250 (47.5)	13,150 (53.5)	13,900 (58)	14,250 (61.5)	14,600 (64.5)	14,600 (66)
55				8,830 (31.5)	9,720 (42.5)	10,550 (49.5)	11,350 (54.5)	11,700 (58.5)	12,100 (62)	12,700 (64)
60				6,800 (20.5)	7,650 (36.5)	8,490 (45)	9,320 (51)	9,710 (55.5)	10,050 (59)	10,550 (61.5)
65					5,960 (29)	6,770 (40)	7,660 (47)	8,040 (52)	8,430 (56)	8,840 (59)
70					4,540 (18.5)	5,340 (34)	6,220 (42.5)	6,650 (48.5)	7,050 (53)	7,400 (56)
75						4,120 (27.5)	5,010 (38)	5,440 (45)	5,850 (50)	6,200 (53.5)
80						3,070 (17.5)	3,970 (32.5)	4,400 (41)	4,810 (47)	5,170 (50.5)
85							3,080 (26)	3,500 (36.5)	3,910 (43)	4,280 (47.5)
90							2,300 (17)	2,710 (31)	3,110 (39.5)	3,510 (44)
95								2,020 (25)	2,420 (35)	2,810 (40.5)
100								1,400 (16)	1,790 (30)	2,170 (36.5)
105									1,240 (24)	1,580 (32)
110										1,050 (27)

Minimum boom angle (deg.) for indicated length (no load) 23 26

Maximum boom length (ft.) at 0 deg. boom angle (no load) 110

#LMI operating code. Refer to LMI manual for instructions.

*This capacity is based upon maximum obtainable boom angle.

Note: () Boom angles are in degrees.

++9 parts of line required to lift this capacity (using aux. boom nose). Refer to Operator's & Safety Handbook for reeving diagram.

Lifting Capacities at Zero Degree Boom Angle

Boom Angle	Main Boom Length in Feet									
	41.3	50	60	**70	80	90	100	110		
0°	20,750 (34.1)	15,150 (42.8)	9,680 (52.8)	5,760 (63)	3,850 (72.8)	2,550 (82.8)	1,900 (92.8)	1,090 (102.8)		

Note: () Reference radii in feet.

**This boom length is with inner-mid fully extended and outer-mid & fly fully retracted.

A6-829-103754

TMS800E

load charts

28



Pounds						
Feet	33 ft. LENGTH			56 ft. LENGTH		
	0° OFFSET	20° OFFSET	40° OFFSET	0° OFFSET	20° OFFSET	40° OFFSET
35	*11,900 (78)					
40	11,900 (75.5)			6,060 (77.5)		
45	11,900 (73.5)	*11,600 (78)		6,060 (76)		
50	11,900 (71.5)	10,600 (75)	*9,700 (78)	6,060 (78)		
55	11,900 (70)	9,770 (73)	8,470 (75.5)	6,060 (73)		
60	11,000 (68)	9,020 (71)	7,920 (73.5)	6,060 (71)	*6,040 (78)	
65	9,930 (66)	8,360 (69.5)	7,430 (72)	6,060 (69.5)	5,900 (75)	
70	8,440 (64)	7,780 (67.5)	6,980 (70)	6,060 (68)	5,730 (73.5)	*4,930 (78)
75	7,170 (62)	7,260 (65.5)	6,580 (68)	6,060 (66)	5,330 (71.5)	4,640 (76)
80	6,080 (60)	6,790 (63.5)	6,210 (65.5)	6,040 (64.5)	4,980 (70)	4,370 (74)
85	5,140 (58)	5,870 (61)	5,870 (63.5)	5,570 (63)	4,650 (68)	4,120 (72)
90	4,310 (55.5)	4,970 (59)	5,540 (61)	4,900 (61)	4,360 (66.5)	3,890 (70)
95	3,570 (53.5)	4,180 (56.5)	4,680 (59)	4,160 (59.5)	4,090 (64.5)	3,680 (68.5)
100	2,920 (51)	3,480 (54.5)	3,910 (56.5)	3,470 (57.5)	3,840 (62.5)	3,480 (66.5)
105	2,340 (48.5)	2,830 (52)	3,220 (54)	2,850 (55.5)	3,610 (60.5)	3,300 (64.5)
110	1,810 (46)	2,250 (49.5)	2,590 (51)	2,300 (53.5)	3,180 (58.5)	3,130 (62.5)
115	1,330 (43.5)	1,720 (46.5)	2,030 (48.5)	1,820 (52)	2,640 (56.5)	2,970 (60)
120		1,240 (44)	1,520 (45)	1,400 (49.5)	2,150 (54.5)	2,740 (58)
125				1,020 (47.5)	1,710 (52.5)	2,200 (55.5)
130					1,300 (50)	1,700 (53)
135						1,240 (50.5)
Minimum boom angle (*) for indicated length (no load)	40.5	42.5	43.5	46.5	48	49
Maximum boom length (ft.) at 0° boom angle (no load)	80			70		

NOTE: () Boom angles are in degrees. A6-829-103776
 #LMI operating code. Refer to LMI manual for operating instructions.
 *This capacity is based upon maximum boom angle.

NOTES:

1. All capacities above the bold line are based on structural strength of boom extension and do not exceed 85% of tipping loads, in accordance with SAE J-765.
2. The 33 ft. extension length may be used with single or double part line lifting service. The 56 ft. extension length may be used for single line lifting service only.
3. For main boom lengths less than 128 ft. with the boom extension erected, the rated loads are determined by boom angle. Use only the column which corresponds to the boom extension length and offset for which the machine is set up. For boom angles not shown, use rating of the next lower boom angle.
4. **WARNING:** Operation of this machine with heavier loads than the capacities listed is strictly prohibited. Machine tipping with boom extension occurs rapidly and without advance warning.
5. Boom angle is the angle above or below horizontal of the longitudinal axis of the boom base section after lifting rated load.
6. Capacities listed are with outriggers properly extended and vertical jacks set only.
7. When lifting over the main boom nose with 33 ft. or 56 ft. extension erected, the outriggers must be fully extended or 50% extended (15 ft. 5 in. spread).

TMS800E

GROVE

THIS CHART IS ONLY A GUIDE AND SHOULD NOT BE USED TO OPERATE THE CRANE. The individual crane's load chart, operating instructions and other instructional plates must be read and understood prior to operating the crane.

load charts

29

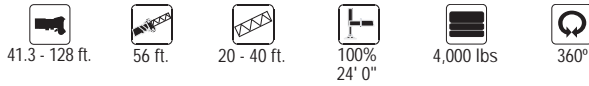

Feet	Pounds					
	76 ft. (56 ft. LENGTH + 1 INSERT)			96 ft. (56 ft. LENGTH + 2 INSERTS)		
	0° OFFSET	20° OFFSET	40° OFFSET	0° OFFSET	20° OFFSET	40° OFFSET
50	4,850 (77.5)					
55	4,850 (76)			3,520 (78)		
60	4,850 (74.5)			3,520 (77)		
65	4,850 (73)	*5,290 (78)		3,520 (75.5)		
70	4,850 (71.5)	4,860 (76.5)		3,520 (74)		
75	4,850 (70)	4,470 (75)		3,520 (72.5)	3,740 (77)	
80	4,730 (68.5)	4,110 (73.5)	4,050 (77)	3,520 (71.5)	3,420 (75.5)	
85	4,310 (67)	3,790 (72)	3,500 (75.5)	3,300 (70)	3,100 (74.5)	*3,250 (78)
90	3,940 (65.5)	3,500 (70)	3,260 (73.5)	2,970 (68.5)	2,820 (73)	2,720 (76)
95	3,610 (63.5)	3,240 (68.5)	3,030 (72)	2,660 (67)	2,560 (71.5)	2,490 (74.5)
100	3,310 (62)	3,000 (67)	2,830 (70.5)	2,390 (65.5)	2,320 (70)	2,270 (73)
105	3,040 (60.5)	2,770 (65)	2,630 (68.5)	2,140 (64)	2,100 (68.5)	2,070 (71.5)
110	2,580 (59)	2,570 (63.5)	2,450 (66.5)	1,920 (62.5)	1,900 (67)	1,890 (70)
115	2,070 (57)	2,370 (61.5)	2,280 (65)	1,710 (61)	1,710 (65.5)	1,710 (68.5)
120	1,600 (55.5)	2,200 (60)	2,120 (63)	1,320 (59.5)	1,540 (64)	1,550 (66.5)
125	1,180 (53.5)	1,970 (58)	1,970 (61)		1,380 (62.5)	1,390 (65)
130		1,510 (56.5)	1,830 (59)		1,230 (60.5)	1,250 (63.5)
135		1,090 (54.5)	1,520 (57)			1,110 (61.5)
140			1,130 (55)			
Minimum boom angle (°) for indicated length (no load)	52.5	53	53.5	58	59	60.5
Maximum boom length (ft.) at 0° boom angle (no load)		60			50	

NOTE: () Boom angles are in degrees. A6-829-103790
 #LMI operating code. Refer to LMI manual for operating instructions.
 *This capacity is based upon maximum boom angle.

NOTES:

1. All capacities above the bold line are based on structural strength of boom extension and do not exceed 85% of tipping loads, in accordance with SAE J-765.
2. The 56 ft. extension length may be used for single line lifting service only.
3. For main boom lengths less than 128 ft. with the boom extension erected, the rated loads are determined by boom angle. Use only the column which corresponds to the boom extension length and offset for which the machine is set up. For boom angles not shown, use rating of the next lower boom angle.
4. **WARNING:** Operation of this machine with heavier loads than the capacities listed is strictly prohibited. Machine tipping with boom extension occurs rapidly and without advance warning.
5. Boom angle is the angle above or below horizontal of the longitudinal axis of the boom base section after lifting rated load.
6. Capacities listed are with outriggers properly extended and vertical jacks set only.
7. When lifting over the main boom nose with 56 ft. extension erected and inserts, the outriggers must be fully extended and vertical jacks set.

TMS800E

load charts

30

Feet	Main Boom Length in Feet									
	41.3	50	60	**70	80	90	100	110	120	128
8	++150,000 (73)									
9	++150,000 (71.5)									
10	141,500 (70)	86,000 (74)	86,000 (77)							
12	125,500 (67)	86,000 (71.5)	86,000 (75)	41,000 (77)						
15	105,500 (62)	86,000 (67.5)	86,000 (71.5)	41,000 (74.5)	39,000 (76.5)					
20	68,500 (53.5)	66,950 (61)	66,050 (66.5)	41,000 (70)	39,000 (73)	38,800 (75)	*38,700 (78)	*31,950 (78)		
25	43,100 (44)	43,150 (54)	42,700 (61)	41,000 (65.5)	39,000 (69)	38,800 (71.5)	38,700 (74)	31,950 (75.5)	*25,750 (78)	*14,600 (78)
30	29,700 (31)	29,950 (46.5)	29,900 (55.5)	29,600 (61)	30,650 (65)	31,750 (68.5)	34,200 (70.5)	31,950 (72.5)	25,750 (74.5)	14,600 (75.5)
35		21,750 (37)	21,850 (49.5)	21,800 (56.5)	22,750 (61)	23,700 (65)	25,200 (67.5)	25,550 (70)	25,750 (72)	14,600 (73)
40		16,150 (24)	16,350 (42)	16,450 (51)	17,400 (57)	18,250 (61)	19,350 (64.5)	19,800 (67.5)	20,250 (69.5)	14,600 (71)
45			12,400 (33.5)	12,550 (45.5)	13,500 (52.5)	14,350 (57.5)	15,200 (61.5)	15,650 (64.5)	16,150 (67)	14,600 (68.5)
50			9,390 (21.5)	9,570 (39)	10,450 (47.5)	11,350 (53.5)	12,100 (58)	12,600 (61.5)	13,100 (64.5)	13,600 (66)
55				7,230 (31.5)	8,120 (42.5)	8,990 (49.5)	9,770 (54.5)	10,200 (58.5)	10,700 (62)	11,100 (64)
60				5,360 (20.5)	6,210 (36.5)	7,050 (45)	7,880 (51)	8,330 (55.5)	8,790 (59)	9,130 (61.5)
65					4,640 (29)	5,460 (40)	6,340 (47)	6,780 (52)	7,210 (56)	7,520 (59)
70					3,330 (18.5)	4,130 (34)	5,020 (42.5)	5,480 (48.5)	5,900 (53)	6,200 (56)
75						3,000 (27.5)	3,900 (38)	4,340 (45)	4,760 (50)	5,080 (53.5)
80						2,030 (17.5)	2,940 (32.5)	3,370 (41)	3,780 (47)	4,110 (50.5)
85							2,110 (26)	2,520 (36.5)	2,920 (43)	3,260 (47.5)
90							1,390 (17)	1,780 (31)	2,170 (39.5)	2,510 (44)
95								1,130 (25)	1,500 (35)	1,820 (40.5)
100										1,220 (36.5)

Minimum boom angle (deg.) for indicated length (no load) 24 29 35
 Maximum boom length (ft.) at 0 deg. boom angle (no load) 100

#LMI operating code. Refer to LMI manual for instructions.
 *This capacity is based upon maximum obtainable boom angle.
 Note: () Boom angles are in degrees.
 ++9 parts of line required to lift this capacity (using aux. boom nose). Refer to Operator's & Safety Handbook for reeving diagram.

Boom Angle	Main Boom Length in Feet						
	41.3	50	60	**70	80	90	110
0°	20,750 (34.1)	13,750 (42.8)	8,000 (52.8)	4,390 (63)	2,690 (72.8)	1,550 (82.8)	1,030 (92.8)

Note: () Reference radii in feet.
 **This boom length is with inner-mid fully extended and outer-mid & fly fully retracted.

A6-829-103755

TMS800E

GROVE

THIS CHART IS ONLY A GUIDE AND SHOULD NOT BE USED TO OPERATE THE CRANE. The individual crane's load chart, operating instructions and other instructional plates must be read and understood prior to operating the crane.

load charts

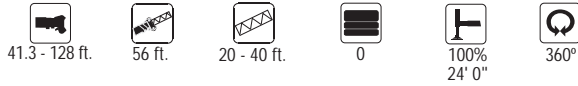

32

Feet	Pounds					
	76 ft. (56 ft. LENGTH + 1 INSERT)			96 ft. (56 ft. LENGTH + 2 INSERTS)		
	0° OFFSET	20° OFFSET	40° OFFSET	0° OFFSET	20° OFFSET	40° OFFSET
50	4,850 (77.5)					
55	4,850 (76)			3,520 (78)		
60	4,850 (74.5)			3,520 (77)		
65	4,850 (73)	*5,290 (78)		3,520 (75.5)		
70	4,850 (71.5)	4,860 (76.5)		3,520 (74)		
75	4,850 (70)	4,470 (75)		3,520 (72.5)	3,740 (77)	
80	4,730 (68.5)	4,110 (73.5)	4,050 (77)	3,520 (71.5)	3,420 (75.5)	
85	4,310 (67)	3,790 (72)	3,500 (75.5)	3,300 (70)	3,100 (74.5)	*3,250 (78)
90	3,700 (65.5)	3,500 (70)	3,260 (73.5)	2,970 (68.5)	2,820 (73)	2,720 (76)
95	3,100 (63.5)	3,240 (68.5)	3,030 (72)	2,660 (67)	2,560 (71.5)	2,490 (74.5)
100	2,560 (62)	3,000 (67)	2,830 (70.5)	2,390 (65.5)	2,320 (70)	2,270 (73)
105	2,080 (60.5)	2,770 (65)	2,630 (68.5)	1,920 (64)	2,100 (68.5)	2,070 (71.5)
110	1,640 (59)	2,410 (63.5)	2,450 (66.5)	1,460 (62.5)	1,900 (67)	1,890 (70)
115	1,240 (57)	1,980 (61.5)	2,280 (65)	1,030 (61)	1,710 (65.5)	1,710 (68.5)
120		1,580 (60)	2,050 (63)		1,490 (64)	1,550 (66.5)
125		1,210 (58)	1,640 (61)		1,080 (62.5)	1,390 (65)
130			1,260 (59)			1,250 (63.5)

Minimum boom angle (*) for indicated length (no load)	55.5	56.5	57	60	61.5	61.5
Maximum boom length (ft.) at 0° boom angle (no load)		60			50	

NOTE: () Boom angles are in degrees. A6-829-103791
 #LMI operating code. Refer to LMI manual for operating instructions.
 *This capacity is based upon maximum boom angle.

NOTES:

1. All capacities above the bold line are based on structural strength of boom extension and do not exceed 85% of tipping loads, in accordance with SAE J-765.
2. The 56 ft. extension length may be used for single line lifting service only.
3. For main boom lengths less than 128 ft. with the boom extension erected, the rated loads are determined by boom angle. Use only the column which corresponds to the boom extension length and offset for which the machine is set up. For boom angles not shown, use rating of the next lower boom angle.
4. **WARNING:** Operation of this machine with heavier loads than the capacities listed is strictly prohibited. Machine tipping with boom extension occurs rapidly and without advance warning.
5. Boom angle is the angle above or below horizontal of the longitudinal axis of the boom base section after lifting rated load.
6. Capacities listed are with outriggers properly extended and vertical jacks set only.
7. When lifting over the main boom nose with 56 ft. extension erected and inserts, the outriggers must be fully extended and vertical jacks set.

TMS800E

GROVE

THIS CHART IS ONLY A GUIDE AND SHOULD NOT BE USED TO OPERATE THE CRANE. The individual crane's load chart, operating instructions and other instructional plates must be read and understood prior to operating the crane.

load handling

Weight Reductions for Load Handling Devices

33 ft.-56 ft. Folding Boom Extension	
*33 ft. Extension (Erected)	5590 lb.
*56 ft. Extension (Erected)	13060 lb.
*76 ft. (1 insert Erected)	13670 lb.
*96 ft. (2 inserts Erected)	20680 lb.

*Reduction of main boom capacities
(no deduct required for stowed boom extension)

When lifting over swingaway and/or jib combinations, deduct total weight of all load handling devices reeved over main boom nose directly from swingaway or jib capacity.

Auxiliary Boom Nose	136 lb.
---------------------	---------

Hookblocks and Headache Balls:

75 Ton, 4 Sheave	1275 lb. +
40 Ton, 3 Sheave	823 lb. +
10 Ton Overhaul Ball	568 lb. +

+ Refer to rating plate for actual weight.

NOTE: All load handling devices and boom attachments are considered part of the load and suitable allowances MUST BE MADE for their combined weights. Weights are for Grove furnished equipment.

Line Pulls and Reeving Information

Hoists	Cable Specs.	Permissible Line Pulls	Nominal Cable Length
Main	3/4" (19 mm) 6x37 Class, EIPS, IWRC Special Flexible Min. Breaking Strength 58,800 lb.	16,800 lb.	600 ft.
Main & Aux.	3/4" (19 mm) Flex-X 35 Rotation Resistant (Non-rotating) Min. Breaking Strength 85,800 lb.	17,160 lb.	607 ft.

The approximate weight of 3/4" wire rope is 1.5 lb./ft.

Hoist Performance

Wire Rope Layer	Hoist Line Pulls Two Speed Hoist		Drum Rope Capacity (ft.)	
	Low Available lb.*	High Available lb.*	Layer	Total
1	20,250	9,610	101	101
2	18,490	8,770	110	211
3	17,010	8,070	120	331
4	15,750	7,470	129	460
5	14,660	6,960	139	599

*Max. lifting capacity: 6x36 or 35x7 class = 17,160 lb.

Boom Section vs. Section Extension Percentages

Boom sections:	Main Boom Length in Feet									
	41.3	50	60	70	80	90	100	110	120	128
Inner-mid	0	30	65	100	100	100	100	100	100	100
Outer-mid	0	0	0	0	7	34	52	69	86	100
Fly	0	0	0	0	17	34	52	69	86	100

Working Area Diagram

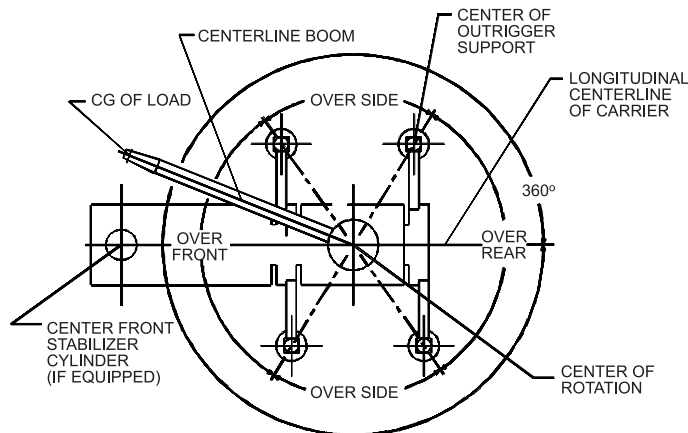

Bold lines determine the limiting position of any load for operation within working areas indicated.

THIS CHART IS ONLY A GUIDE AND SHOULD NOT BE USED TO OPERATE THE CRANE. The individual crane's load chart, operating instructions and other instructional plates must be read and understood prior to operating the crane.

TMS800E

GROVE

Regional Headquarters

Americas

Manitowoc, Wisconsin, USA

Tel: +1 920 684 6621

Fax: +1 920 683 6278

Shady Grove, Pennsylvania, USA

Tel: +1 717 597 8121

Fax: +1 717 597 4062

Regional Offices

Americas

Brazil

Alphaville

Tel: +55 11 4688 2716

Fax: +55 11 4191 1471

Mexico

Monterrey

Tel: +52 81 8124 0128

Fax: +52 81 8124 0129

Europe, Middle East, Africa

Algeria

Hydra

Tel: +21 3 21 48 1173

Fax: +21 3 21 48 1454

Czech Republic

Netvorice

Tel: +420 317 78 9313

Fax: +420 317 78 9314

France

Baudemont

Tel: +33 385 28 2589

Fax: +33 385 28 0430

Cergy

Tel: +33 130 31 3150

Fax: +33 130 38 6085

Decines

Tel: +33 472 81 5000

Fax: +33 472 81 5010

Germany

Langenfeld

Tel: +49 21 73 8909-0

Fax: +49 21 73 8909 30

Hungary

Budapest

Tel: +36 13 39 8622

Fax: +36 13 39 8622

Italy

Parabiago

Tel: +390 331 49 3311

Fax: +390 331 49 3330

Europe, Middle East, Africa

Ecully, France

Tel: +33 472 18 2020

Fax: +33 472 18 2000

Netherlands

Breda

Tel: +31 76 578 3999

Fax: +31 76 578 3978

Poland

Warsaw

Tel: +48 22 843 3824

Fax: +48 22 843 3471

Portugal

Alfena

Tel: +351 229 69 8840

Fax: +351 229 69 8848

Lisbon

Tel: +351 212 109 340

Fax: +351 212 109 349

Russia

Moscow

Tel: +7 495 641 2359

Fax: +7 495 641 2358

U.A.E.

Dubai

Tel: +971 4 3381 861

Fax: +971 4 3382 343

U. K.

Middlesex

Tel: +44 1 895 43 0053

Fax: +44 1 895 45 9500

Sunderland

Tel: +44 191 522 2000

Fax: +44 191 522 2052

Asia – Pacific

Australia

Melbourne

Tel: +61 3 9 336 1300

Fax: +61 3 9 336 1322

Sydney

Tel: +61 2 9 896 4433

Fax: +61 2 9 896 3122

Asia – Pacific

Shanghai, China

Tel: +86 21 51113579

Fax: +86 21 51113578

Singapore

Tel: +65 6264 1188

Fax: +65 6862 4142

China

Beijing

Tel: +86 10 58674761

Fax: +86 10 58674760

Xi'an

Tel: +86 29 87891465

Fax: +86 29 87884504

Korea

Seoul

Tel: +82 2 3439 0400

Fax: +82 2 3439 0405

Philippines

Makati City

Tel: +63 2 844 9437

Fax: +63 2 844 4712

Factories

U.S.A.

Manitowoc

Shady Grove

Brazil

Alphaville

France

Charlieu

La Clayette

Moulins

India

Calcutta

Puna

Italy

Niella Tanaro

Germany

Wilhelmshaven

Portugal

Fânzeres

China

Zhangjiagang