

# Technical Data

## Specifications & Capacities

# 348

HYLAB 5

**Crawler Crane**  
300 Ton (272.16 metric ton)

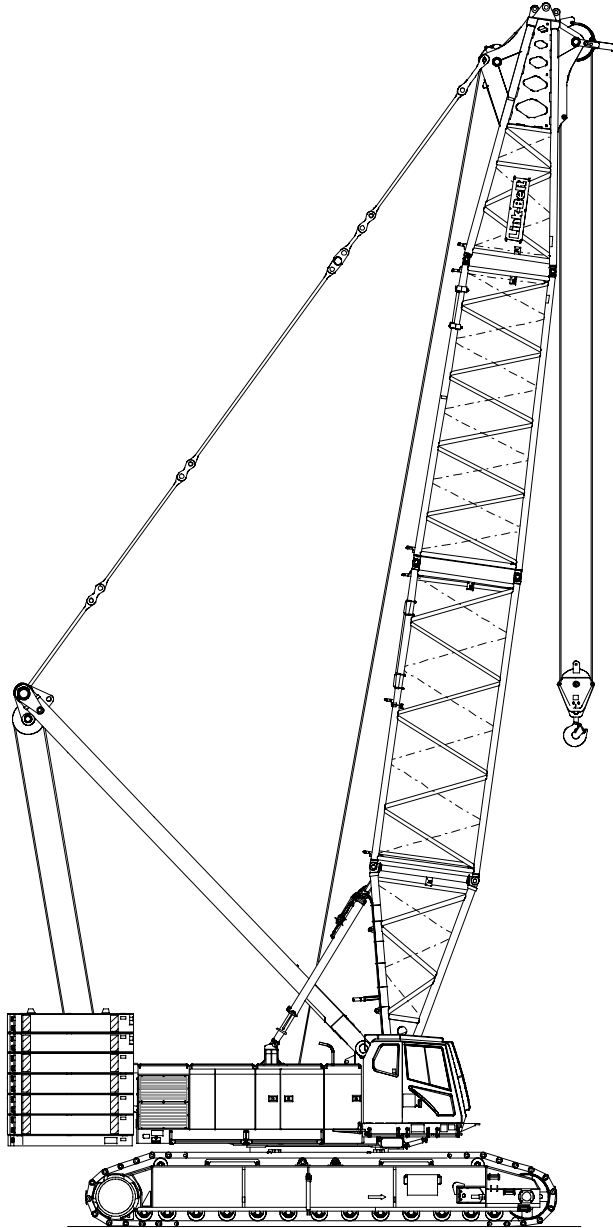

CAUTION: This material is supplied for reference use only. Operator must refer to in-cab Crane Rating Manual and Operator's Manual to determine allowable crane lifting capacities and assembly and operating procedures.



# Table Of Contents

<b>Upper Structure</b> .....	<b>1</b>
Frame .....	1
Engine .....	1
Hydraulic System .....	1
Load Hoist Drums .....	1
Optional Front–Mounted Third Hoist Drum .....	2
Boom Hoist Drum .....	2
Boom Hoist System .....	2
Swing System .....	2
Counterweight .....	2
Operator’s Cab .....	2
Rated Capacity Limiter System .....	2
Machinery Cab .....	2
Catwalks .....	2
<b>Lower Structure</b> .....	<b>3</b>
Carbody .....	3
Side Frames .....	3
Travel and Steering .....	3
Jack System .....	3
Carbody Counterweight .....	3
<b>Attachment and Options</b> .....	<b>4</b>
Heavy Duty Boom .....	4
Long Range Boom .....	4
Jib .....	4
Auxiliary Tip Extension .....	4
Luffing Boom .....	5
Luffing Jib .....	5
Fixed Jib .....	5
<b>Dimensions</b> .....	<b>6</b>
Base Crane .....	7
Side Frames .....	7
Upper Counterweights .....	8
Lower Counterweights .....	9
Boom .....	10
Jib/Fixed Jib .....	13
Luffing Jib .....	14
Hook Blocks .....	15
Hook Balls .....	15
Assembly Diagram .....	16
<b>Working Weights</b> .....	<b>16</b>
<b>Transport Weights</b> .....	<b>17</b>
<b>Transport Drawings</b> .....	<b>18</b>
<b>Load Hoist Performance</b> .....	<b>20</b>
<b>Working Areas</b> .....	<b>21</b>

<b>Attachments</b> .....	<b>22</b>
<b>Heavy Duty Boom</b> .....	<b>24</b>
Boom Make–Up .....	24
Working Range Diagram – Extended Gauge .....	25
Load Chart – Extended Gauge .....	26
Working Range Diagram – Retracted Gauge .....	27
Load Chart – Retracted Gauge .....	28
<b>Long Range Boom</b> .....	<b>29</b>
Boom Make–Up .....	29
Working Range Diagram – Extended Gauge .....	30
Load Chart – Extended Gauge .....	31
Working Range Diagram – Retracted Gauge .....	33
Load Chart – Retracted Gauge .....	34

# Upper Structure

## Frame

All welded and precision machined surfaces.

### Turntable Bearing

- Outer race bolted to upper frame; inner race with internal swing gears bolted to lower frame.

## Engine

### Engine

Full pressure lubrication, oil filter, air cleaner, hour meter, throttle, and electric control shutdown.

Mitsubishi 6M70–TL	
Number of cylinders	6
Bore and stroke	5.31 x 5.91 in (135 x 150mm)
Piston displacement	786 in <sup>3</sup> (12.9L)
Engine rpm at full load speed	2,000
Hi–idle rpm	2,100
Gross engine hp	365 hp (272kw)
Peak torque	1,114 ft lb (1 510joule) @ 1,500 rpm
Electrical system	24 volt
Fuel tank capacity	132 gal (500L)
Batteries	2–12 volt
Approximate fuel consumption	gal/hr (L/hr)
100% hp	5.4 (20.4)
75% hp	5.6 (21.1)
50% hp	6.2 (23.4)

### Fuel Tank

Equipped with fuel sight level gauges, flame arrester, and self–closing cap with locking eye for padlock.

## Hydraulic System

### Hydraulic Pumps

The pump arrangement is designed to provide hydraulically powered functions allowing positive, precise control with independent or simultaneous operation of all crane functions.

- Two variable displacement pumps operating at 4,550 psi (320kg/cm<sup>2</sup>) and 110 gal/min (416L/min) powers the load hoist drums, boom hoist drum, optional third drum, optional fourth drum, and travel.
- One variable displacement pump operating at 3,560 psi (250kg/cm<sup>2</sup>) and 61.0 gal/min (231L/min) powers the swing motor.
- One fixed displacement gear type pump operating at 3,270 psi (230kg/cm<sup>2</sup>) and 16.4 gal/min (62L/min) powers the self–assembly cylinder, counterweight lifting, lower jacks, and hydraulic backstop and sideframe pin cylinders.
- One fixed displacement gear type pump operating at 1,140 psi (80kg/cm<sup>2</sup>) and 11.1 gal/min (42.2L/min) powers the remote control valves, counterweight pin and boom foot pin cylinders.
- One fixed displacement gear type pump operating at 1,990 psi (140kg/cm<sup>2</sup>) and 8.5 gal/min (32.1L/min) powers the fan for the oil cooler, cab tilt cylinders, and counterweight lifting cylinders at high speed.
- One fixed displacement gear type pump operating at 35.6 psi (2.5kg/cm<sup>2</sup>) and 3.0 gal/min (11.4L/min) powers the splitter oil cooler.
- One fixed displacement gear type pump operating at 4,550 psi (320kg/cm<sup>2</sup>) and 8.7 gal/min (32.9L/min) powers the live mast flip cylinders.

### Remote Oil Cooler

Oil cooler, located behind the operator's cab, has a hydraulically driven, thermostatically controlled fan to control oil temperature.

### Pump Control “Fine Inching” Mode

Special pump setting, selectable from the operator's cab, that allows very slow movements of load hoist drums, boom hoist drum, and travel for precision work.

### Hydraulic Reservoir

108 gal (409L), equipped with sight level gauge. Diffusers built in for deaeration.

### Filtration

Ten micron, full flow, line filter in the control circuit. All oil is filtered prior to entering the reservoir.

### Counterbalance Valves

All hoist motors are equipped with counterbalance valves to provide positive load lowering and prevent accidental load drop if the hydraulic pressure is suddenly lost.

## Load Hoist Drums

Each drum contains a pilot controlled, bi–directional, axial piston motor and a planetary gear reduction unit to provide positive control under all load conditions.

- Power up/down with optional free–fall operation modes
- Automatic brake mode (spring applied, hydraulically released, band type brake)
- Drum pawl controlled manually
- Electronic drum rotation indicators
- Mounted on anti–friction bearings
- 22.68 in (57.61cm) root diameter
- 44.88 in (114.00cm) flange diameter
- 27.13 in (68.91cm) width

The free–fall operation mode is designed to prevent load lowering even if the free–fall switch is accidentally activated.

The automatic brake mode meets all OSHA requirements for personnel handling.

### Drum Clutches

Hydraulic two shoe clutch design that uses a 37 in (939mm) diameter x 5.5 in (140mm) wide shoe that expands internally to provide load control.

## Optional Front–Mounted Third Hoist Drum

- Mounts in the boom base section
- Power up/down for luffer applications
- 20.72 in (526.3mm) root diameter
- 34.84 in (885mm) flange diameter
- 11.54 in (293.1mm) width

## Boom Hoist Drum

Contains a pilot controlled, bi–directional, axial piston motor and a planetary gear reduction unit to provide positive control under all load conditions.

- Spring applied, hydraulically released, disc type brake controlled automatically
- Electronic drum rotation indicators
- Drum pawl controlled automatically
- Mounted on anti–friction bearings
- 20.98 in (5329cm) root diameter (right)
- 20.47 in (51.99cm) root diameter (left)
- 39.37 in (100.00cm) flange diameter
- 11.26 in (28.60cm) width (right)
- 11.26 in (28.60cm) width (left)

## Boom Hoist System

Designed to lift off maximum boom or maximum boom plus jib and maximum luffing attachment unassisted. Operates up to a maximum boom angle of 83°. Boom hoist limit system limits maximum boom angle operation.

- Pin–on bail frame
- 24–part reeving with 1 in (26mm) wire rope
- Bridle assembly
- 32 ft (9.75m) Live mast
- Hydraulic tubular boom backstops
- Sheaves contain sealed anti–friction bearings

## Swing System

Pilot controlled, bi–directional, axial piston motors and planetary gear reduction units to provide positive control under all load conditions.

- Spring applied, hydraulically released, 360° multi–plate brake
- Free swing mode when lever is in neutral position
- Four position positive house lock
- Audio/Visual swing alarm
- Maximum swing speed is 1.7 rpm
- Swing damper

## Counterweight

Consists of a 13–piece design that can be easily lowered to the ground using the hydraulic counterweight removal system.

- “A” upper counterweight consists of one, 36,128 lb (16 387kg) base slab and two, 17,086 lb (7 750kg) type “1” counterweights.
- “AB” upper counterweight consists of all “A” counterweight plus four, 17,086 lb (7 750kg) type “1” counterweights and two, 16,755 lb (7 600kg) type “2” counterweights.
- “ABC” upper counterweight consists of all “AB” counterweight plus four, 12,125 lb (5 500kg) type “3” counterweights.

Total combined counterweight, “ABC” is 221,100 lb (100 289kg). “C” counterweight is an optional item.

## Operator’s Cab

Fully enclosed modular steel compartment is independently mounted and padded to protect against vibration and noise.

- Cab tilts up to 20°
- All tinted/tempered safety glass
- Sliding entry door and front window
- 19,000 BTU hot water heater
- 18,600 BTU air conditioner
- Door and window locks
- Circulating fan
- Sun visor
- Cloth seat
- Defroster
- Windshield wipers and washer
- Dry chemical fire extinguisher

- Engine instrumentation panel (tachometer, voltmeter, engine oil pressure, engine water temperature, fuel level, hydraulic oil temperature, hour meter, and service monitor system)
- Electronic drum rotation indicators for front and rear hoist drums
- Six way adjustable seat
- Foot throttle
- Fully adjustable single axis controls
- Swing lever with twist–grip throttle with variable pump output control, swing brake, and horn located on handle
- Bubble type level
- Ergonomic gauge layout
- Controls shut off lever
- Right hand control stand is adjustable by electric motor for operator comfort.

## Rated Capacity Limiter System

The rated capacity limiter system is a boom hoist load cell system. This system provides the operator with useful geometrical data, to include:

- Main boom length
- Main boom angle
- Live mast angle indicator
- Live mast load indicator
- Jib length
- Jib angle
- Operating mode
- Load radius
- Boom tip height
- Audible alarm
- Pre–warning light
- Overload light
- Load on hook
- Function kick–outs including over load
- Operator settable stops (ramped stops)
- Anti–two block indicator
- Boom hoist dead end load cell (no lineriders)

## Machinery Cab

Hinged doors (five on right side, four on left side) for machinery access. Equipped with rooftop access ladder and skid resistant finish on roof.

## Catwalks

Standard on right and left sides. Catwalks fold and pin for reduced transport width.

# Lower Structure

## Carbody

### Lower Frame

All welded high strength steel [100,000 psi (689.48MPa) yield] box construction frame with precision machined surfaces for turntable bearing and rotating joint.

- 11 ft 2 in (3.2m) overall width
- 17 ft 9 in (5.41m) overall length

## Side Frames

### Side Frames

All welded, precision machined. Carbody cross axles positioned by dowels and held in place with adjustable wedge packs.

- 19 ft 2 in (5.84m) retracted gauge
- 22 ft 0 in (6.71m) extended gauge
- 30 ft 8 in (9.35m) overall length
- 50 in (1.27m) wide track shoes – standard
- 60 in (1.52m) wide track shoes – optional
- Sealed (oil filled) idler and drive planetaries
- Compact travel drives
- Hydraulic self-adjusting track tension system

### Track Rollers

- Thirteen sealed (oil filled) track rollers per side frame
- Four sealed auxiliary (carrier roller) track rollers per side frame

## Tracks

Heat treated, self-cleaning, multiple hinged track shoes joined by one-piece full floating pins; 60 shoes per side frame

### Take Up Idlers

Cast steel, heat treated, self-cleaning, mounted on aluminum/bronze bushings, lubricated through the idler shaft.

- **Track Tension Adjustment** – Idler adjusted by means of automatic track tension device. Hydraulic cylinder provides proper track tension. Track tension determined by stop bolt.

## Travel and Steering

### Travel and Steering

Each side frame contains a pilot controlled, bi-directional, axial piston motor and a planetary gear reduction unit to provide positive control under all load conditions.

- Individual control provides smooth, precise maneuverability including full counter-rotation.
- Spring applied, hydraulically released disc type brake controlled automatically
- Axial piston motor with reduction gear is located at inner drive end of each side frame. Each track is driven simultaneously or individually for straight-line, gradual turn, or pivot turn.
- Maximum travel speed is 1 mph (1.61km/h).
- Designed to 30% gradeability

## Jack System

System contains four hydraulic cylinders individually mounted on swing-out beams.

- Individual jack cylinders are operated by remote control, or can be operated by carbody-mounted controls
- Minimum height of carbody when resting on pontoons is 17.4 in (44.20cm).
- Maximum height of carbody when resting on pontoons is 44.0 in (111.76cm).

## Carbody Counterweight

Consists of a 3-piece design

- Slab “1” carbody counterweight consists of one, 11,243 lb (5 100kg) slab.
- Slab “2” carbody counterweight consists of one, 11,464 lb (5 200kg) slab.
- Base slab carbody counterweight, 14,770 lb (6 670kg).

Total combined carbody counterweight with hardware is 37,500 lb (17 010kg) each.

# Attachment and Options

## Heavy Duty Boom 70–300 ft (21.34–91.44m)

### Basic Boom

70 ft (21.34m) four-piece design that utilizes a 15 ft (4.57m) base section, 20 ft (6.10m) base extension, 20 ft (6.10m) tapered extension, and 15 ft (4.57m) top section with in-line connecting pins on 95 in (2.41m) wide and 80 in (2.03m) deep centers.

- Boom foot on 56.50 in (1.44m) centers
- 6 in (15.24cm) diameter tubular chords on base section and top section
- 5.25 in (13.34cm) diameter tubular chords on extensions
- Skywalk platform on 20 ft (6.10m) base extension
- Offset head sheaves
- Permanent stands mounted on top section to protect head machinery
- Seven 23 in (0.58m) root diameter poly-mide sheaves mounted on sealed anti-friction bearings
- Tip extension and jib connecting lugs on top section
- Mechanical boom angle indicator

### Heavy Duty Boom Extensions

The following table provides the lengths available and the suggested quantity to obtain maximum boom.

Heavy Duty Tube Boom Extensions		Quantity For Max Boom
ft	m	
<b>“JC” Heavy Duty Boom</b>		
20	6.10	2
30	9.14	1
40	12.19	4

- Midpoint pendant connections are required at 165 ft (50.29m) for boom lengths 250 ft (76.20m) through 300 ft (91.44m).
- Polyamide wear blocks on top of each extension
- Appropriate length bar pendants stored on extension
- Maximum tip height of 305 ft (92.96m)
- Boom connecting pin storage on each extension

## Long Range Boom 85–355 ft (25.91–108.20m)

### Basic Boom

85 ft (25.91m) four-piece design that utilizes a 15 ft (4.57m) base section, 20 ft (6.10m) base extension, 20 ft (6.10m) tapered extension, and 30 ft (9.14m) long range top section with in-line connecting pins on 80 in (2.03m) wide and 68 in (1.73m) deep centers.

- Six 21 in (0.53m) root diameter poly-mide sheaves mounted on sealed anti-friction bearings
- Tip extension and jib connecting lugs on top section
- Long range boom is luffing jib for luffing attachment

### Long Range Boom Extensions

The following table provides the lengths available and the suggested quantity to obtain maximum boom.

Boom Extensions		
ft	m	Quantity For Max Boom
<b>“JC” Heavy Duty Boom</b>		
20	6.10	1
30	9.14	1
40	12.19	2
<b>“FE” Long Range Boom</b>		
10	3.05	1
20	6.10	1
30	9.14	1
40	12.19	2

- Midpoint pendant connections are required at 165 ft (50.29m) for boom lengths 225 ft (68.58m) through 355 ft (108.20m).
- Polyamide wear blocks on top of each extension
- Appropriate length bar pendants stored on extension
- Maximum tip height of 360 ft (109.73m)
- Boom connecting pin storage on each extension

## Jib 40–140 ft (12.19–42.67m)

### Basic Tube Jib

40 ft (12.19m) two-piece design that utilizes a 20 ft (6.10m) base section and a 20 ft (6.10m) top section with in-line connecting pins on 48 in (1.22m) wide and 39 in (0.99m) deep centers.

Jib Extensions		Quantity For Max Jib
ft	m	
20	6.10	5

- 3.00 in (7.62cm) diameter tubular chords
- One 23 in (0.58m) root diameter steel sheave mounted on sealed anti-friction bearings
- 20 ft (6.10) jib extensions are available to provide jib lengths of 40–140 ft (12.19–42.67m) in 20 ft (6.10m) increments
- Jib offset angles at 5°, 25°, and 45°
- The maximum tip height of tube boom + jib [295 ft + 140 ft (89.92 + 42.67m)] is 435 ft (132.59m).
- Can be used as fixed jib on luffing attachment

## Auxiliary Tip Extension 5 ft (1.5m)

Designed to use in place of jib to provide clearance between working hoist lines. The extension is equipped with two poly-mide 21 in (0.53m) root diameter sheaves mounted on sealed anti-friction bearings. Maximum capacity is 20 Tons (18.14mt).

## Luffing Boom 130–200 ft (39.62–60.96m)

- Common base and extensions with heavy duty boom (“JC” boom only)
- 10 ft (3.05m) luffing extension required for bail anchor
- Working angles of 90°, 85°, 80°, 75°, 70°, and 65°
- Working lengths of 130 ft (39.62m) to 200 ft (60.71m)
- Third drum becomes luffing jib hoist
- Rear drum provides second load hoist
- Designed for self-assembly
- Luffing jib hoist bridle and bail can remain reeved for crane transport
- Job site mobility with attachment
- Compact transport module

### Luffing Boom Extensions

The following table provides the lengths available and the suggested quantity to obtain the maximum luffing boom. Midpoint pendants are not required.

Luffing Boom Extensions		Quantity For Max Luffing Boom
ft	m	
<b>“JC” Wall</b>		
20	6.10	1
30	9.14	1
40	12.19	2

## Luffing Jib 100–240 ft (30.48–73.15m)

### Basic Luffing Jib

100 ft (30.48m) basic luffing jib design utilizes a 20 ft (6.10m) luffing jib base section, 50 ft (15.24m) of luffing jib extensions, and a 30 ft (9.14m) top section with in-line connecting pins on 80 in (2.03m) wide and 68 in (1.73m) deep centers.

- Working lengths of 100 ft (30.48m) to 240 ft (73.15m)
- Top section includes mounting lugs for fixed jib
- Six 21 in (0.53m) root diameter poly-mide luffing jib head sheaves mounted on anti-friction bearings
- Two 23 in (0.58m) root diameter poly-mide luffing boom auxiliary head sheaves mounted on anti-friction bearings
- Pin-on nose wheel
- Twelve-part luffing jib hoist
- Appropriate length bar pendants stored on extension
- The maximum boom length of luffing boom + luffing jib [180 ft + 240 ft (54.86 + 73.15m)] is 420 ft (128.02m).

### Luffing Jib Extensions

The following table provides the lengths available and the suggested quantity to obtain the maximum luffing jib. Midpoint pendants are not required.

Luffing Jib Extensions		Quantity For Max Luffing Jib
ft	m	
<b>“FE” Wall</b>		
10	3.05	1
20	6.10	2
30	9.14	2
40	12.19	2

**Note:** Long range boom extensions make-up luffing jib.

- Polymide wear blocks on top of each section
- The maximum tip height is 417.3 ft (127.2m).

## Fixed Jib 80 ft (24.38m)

### Basic Tube Jib

80 ft (24.38m) design that utilizes a 20 ft (6.10m) base section, two 20 ft (6.10m) extensions, and a 20 ft (6.10m) top section with in-line connecting pins on 48 in (1.22m) wide and 39 in (0.99m) deep centers.

- Two 20 ft (6.10m) extensions available for 80 ft (24.38m) fixed jib.
- 3.00 in (7.62cm) diameter tubular chords
- One 23 in (0.58m) root diameter steel sheave mounted on sealed anti-friction bearings
- The maximum tip height of 446.2 ft (136.0m).

# Dimensions

General Dimensions	English	Metric
Basic Boom	70 ft	21.34m
Minimum Load Radius	15.51 ft	4.73m
Maximum Boom Angle	82°	82°
Ground clearance (jacks)	1' 5.44"	0.44m
Track Shoe Width	50 in	1.27m
Optional track Shoe Width	60 in	1.52m

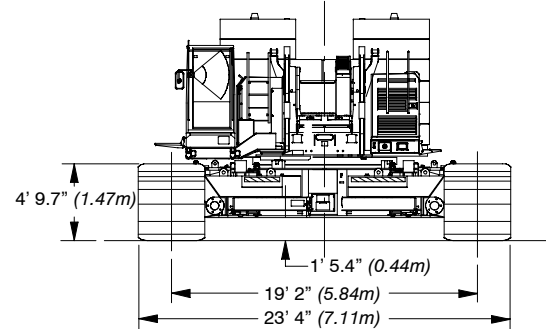
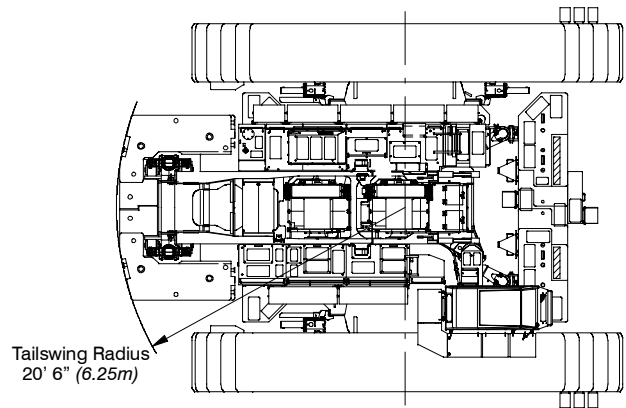
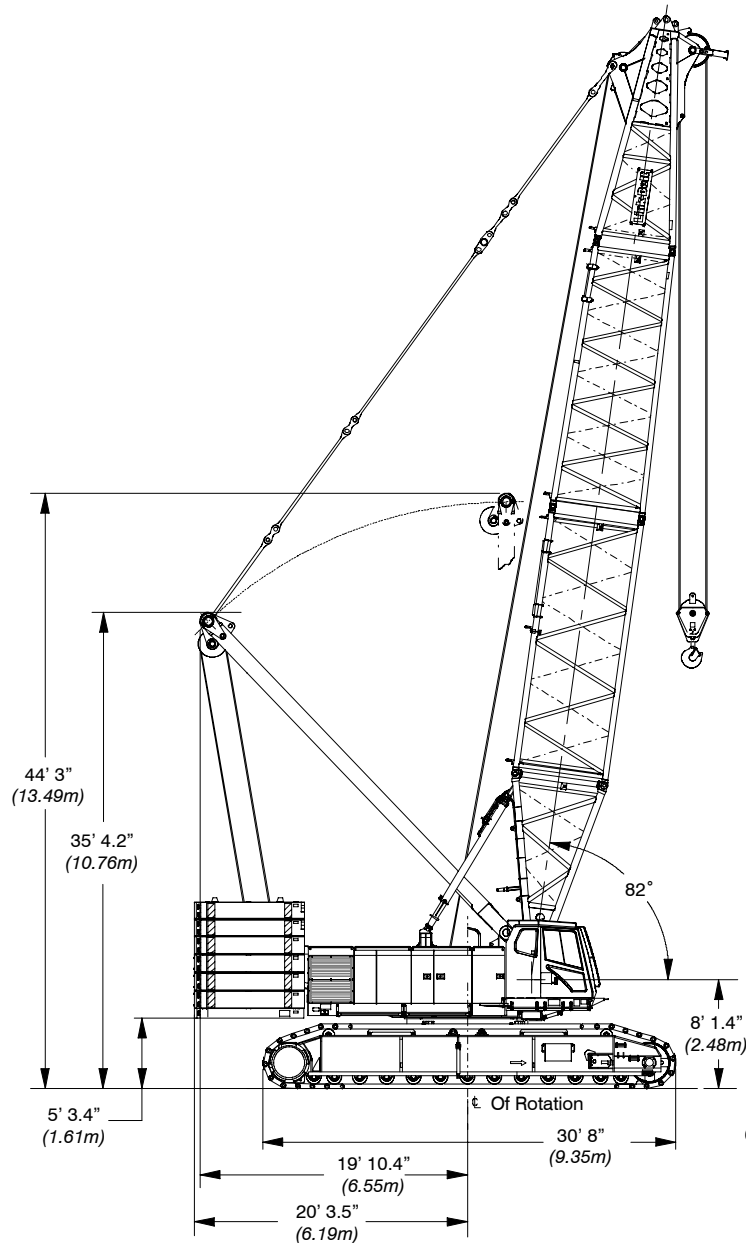

**Retracted**

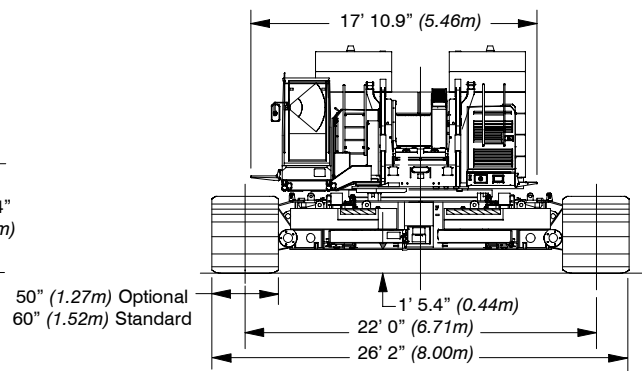

**Extended**

# Base Crane

## Base Crane ①

Length 1	17' ft 8.9"	(5.41m)
Length 2	40' ft 1.6"	(12.23m)
Length 3	7 ft 10.9 in	(2.41m)
Width	13 ft 10.9 in	(4.24m)
Height 1	11 ft 2.2 in	(3.41m)
Height 2	44.0 in	(1.12m)
Height 3	44.6 in	(1.13m)
Weight*		
with ctwt removal	95,900 lb	(43 500kg)
without ctwt removal	92,300 lb	(41 867kg)

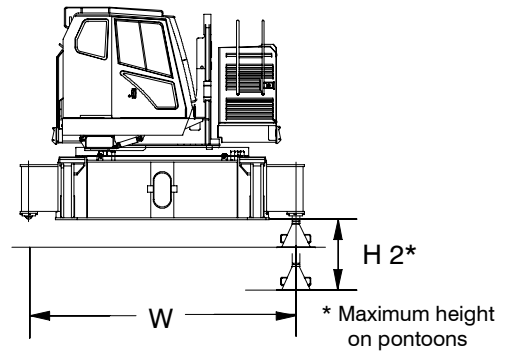

\* Includes: 1,230 ft (374.90m) of 1.02 in (26mm) "FC" rope (boom hoist)  
 960 ft (292.61m) of 1.10 in (28mm) "GC" rope (rear hoist)  
 1,625 ft (495.30m) of 1.10 in (28mm) "GC" rope (front hoist)  
 Add 4,200 lb (1 905kg) for free fall capable winches

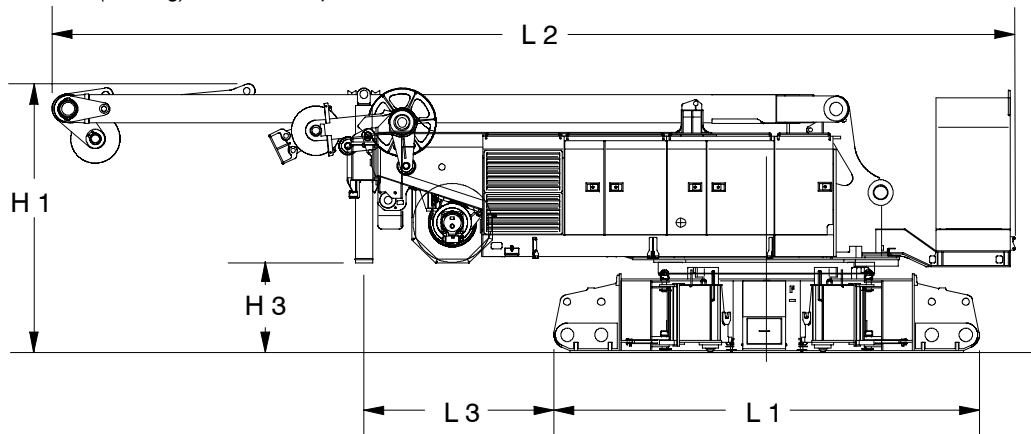

# Side Frames

## With 50 in (1.27m) Track Shoes ②

Length	30 ft 8 in	(8.16m)
Width	50 in	(1.27m)
Height	57.7 in	(1.47m)
Weight	45,000 lb	(20 412kg)

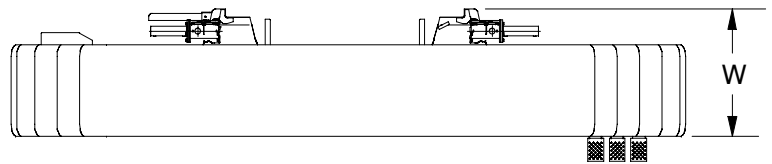

## With 60 in (1.52m) Track Shoes ②

Length	30 ft 8 in	(8.16m)
Width	60 in	(1.52m)
Height	57.7 in	(1.47m)
Weight	48,650 lb	(22 067kg)

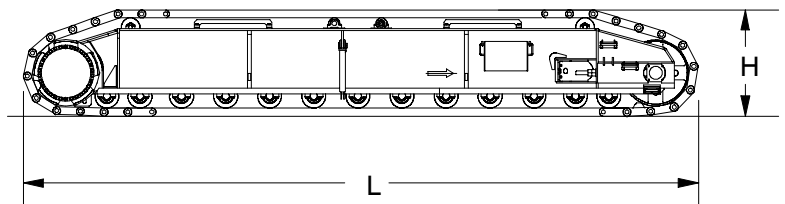

Number inside black circle "①" = # of components

# Upper Counterweights

## Base Counterweight ①

Length	8 ft 1 in	(2.46m)
Width	12 ft 11.1 in	(3.94m)
Height	4 ft 9.9 in	(1.47m)
Weight	36,128 lb	(16 388kg)

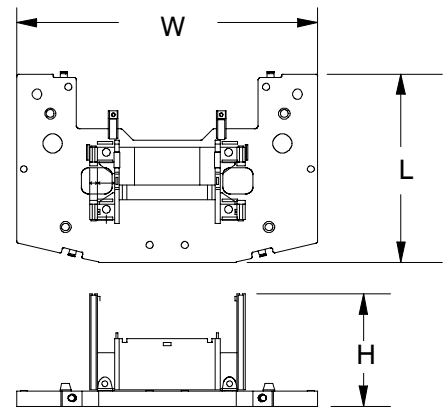

## #1 Counterweight ⑥

Length	8 ft 2.4 in	(2.5m)
Width	6 ft 7.9 in	(2.3m)
Height	1 ft 7.9 in	(0.5m)
Weight	17,086 lb	(8 101kg)

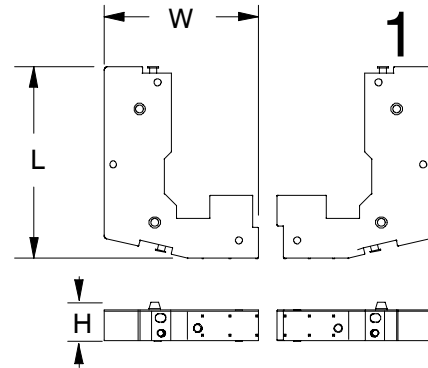

## #2 Counterweight ②

Length	8 ft 2.4 in	(2.5m)
Width	6 ft 7.9 in	(2.3m)
Height	1 ft 7.9 in	(0.5m)
Weight	16,755 lb	(7 600kg)

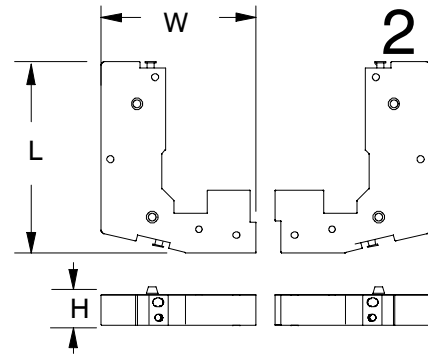

## #3 Counterweight ④

Length	8 ft 2.4 in	(2.5m)
Width	4 ft 9.1 in	(1.45m)
Height	1 ft 7.1 in	(0.48m)
Weight	12,125 lb	(5 499kg)

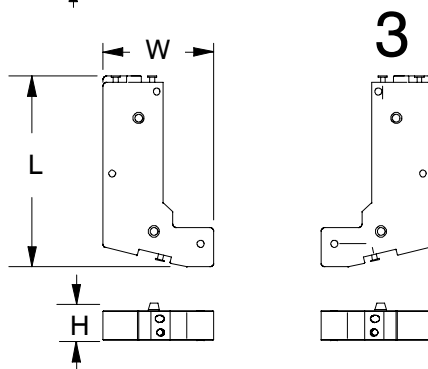

Number inside black circle "①" = # of components

## Upper Counterweight Configurations

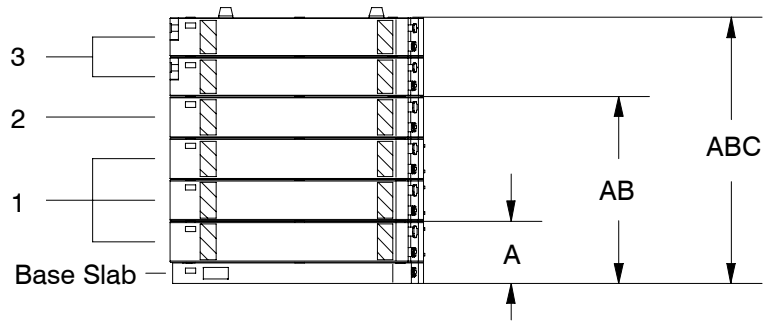

## Lower Counterweights

### Base Carbody Counterweight 2

Length	11 ft 6 in	(3.51m)
Width	4 ft 2.6 in	(1.29m)
Height	10 in	(0.25m)
Weight	14,770 lb	(6 670kg)

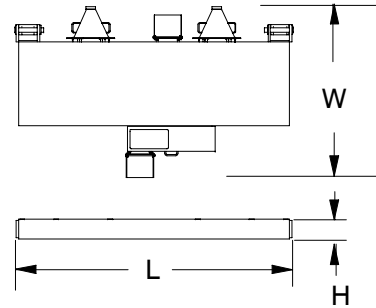

### Carbody Counterweight Slabs 4

Length	6 ft 7.7 in	(2.25m)
Width	4 ft 2.6 in	(1.29m)
Height	1 ft 3.7 in	(0.4m)
Weight		
Slab 1	11,243 lb	(5 100kg)
Slab 2	11,464 lb	(5 200kg)

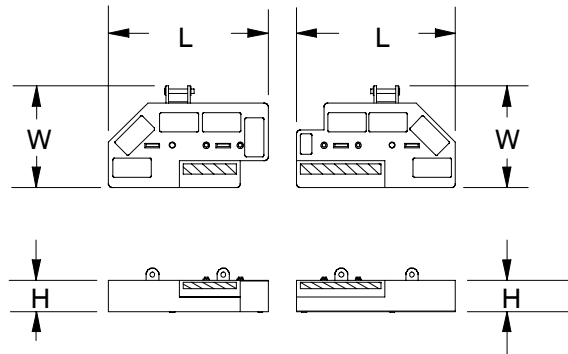

Number inside black circle "1" = # of components

# Boom

## 80 in (2.03m) x 95 in (2.41m) Heavy Duty Boom Extensions “JC”

Weights Include Pendants and Hardware

### 20 ft (6.10m) Extension

Weight: 3,651 lb (1 656kg)

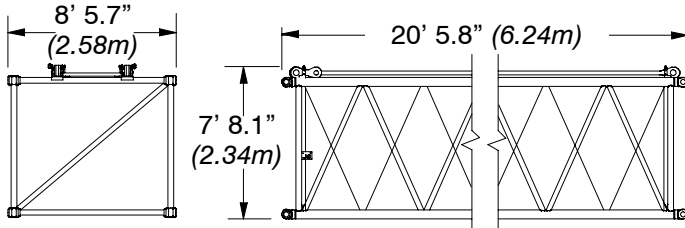

### 30 ft (9.14m) Extension

Weight: 5,187 lb (2 353kg)

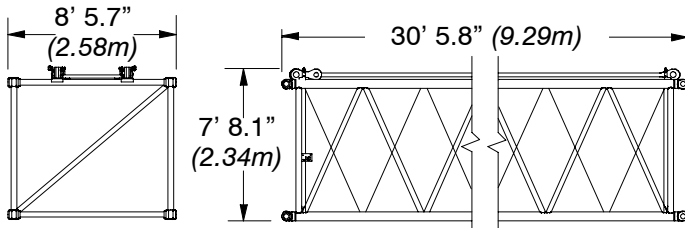

### 40 ft (12.19m) Extension

Weight: 6,552 lb (2 972kg)

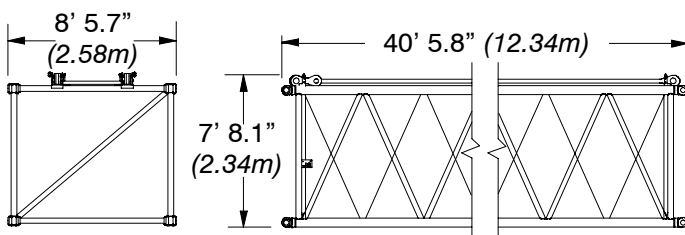

## 68 in (1.72m) x 80 in (2.03m) Long Range Boom Extensions “FE”

Weights Include Pendants and Hardware

### 10 ft (3.05m) Extension

Weight: 1,338 lb (607kg)

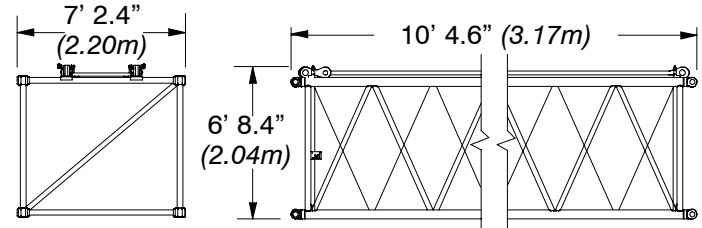

### 20 ft (6.10m) Extension

Weight: 2,162 lb (981kg)

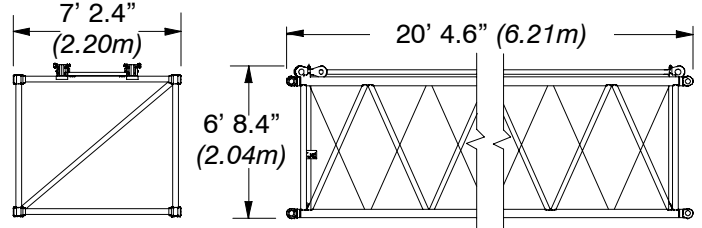

### 30 ft (9.14m) Extension

Weight: 2,992 lb (1 357kg)

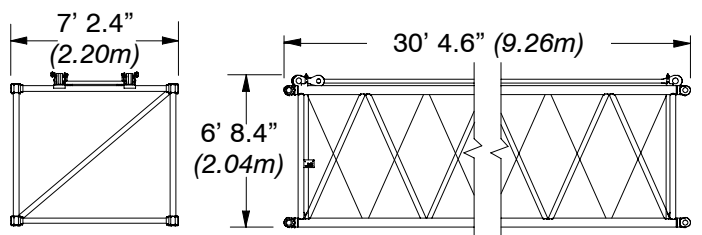

### 40 ft (12.19m) Extension

Weight: 3,823 lb (1 734kg)

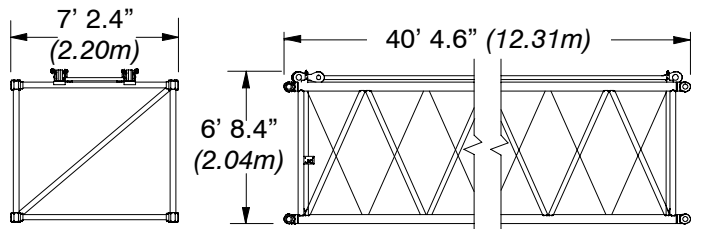

**15 ft (6.10m) Heavy Duty/  
Long Range Boom  
Base Section “N”** ①

Length 1	15 ft 9.5 in	(4.81m)
Length 2	16 ft 1.8 in	(4.92m)
Width	8 ft 6 in	(2.59m)
Deep	80 in	(2.03m)
Height 1	7 ft 6.3 in	(2.29m)
Height 2	7 ft 1 in	(2.16m)
Weight	6,350 lb	(2 880kg)

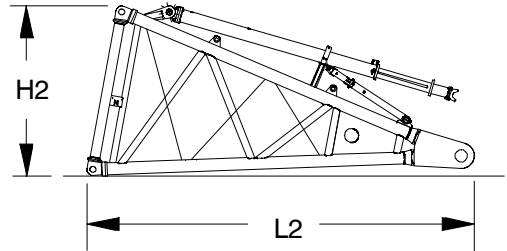
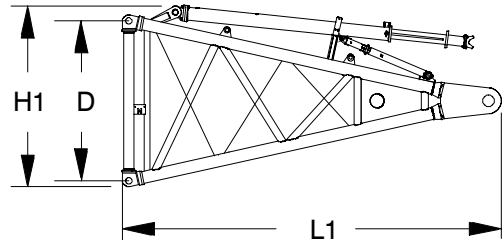
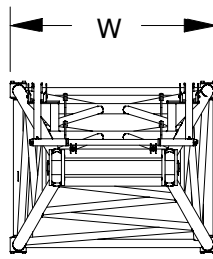

**20 ft (6.10m) Heavy Duty/  
Long Range Boom  
Base Extension “JT”** ①

Length	20 ft 5.8 in	(6.24m)
Width	8 ft 5.7 in	(2.58m)
Deep	80 in	(2.03m)
Height	7 ft 8.1 in	(2.34m)
Weight	4,126 lb	(1 872kg)

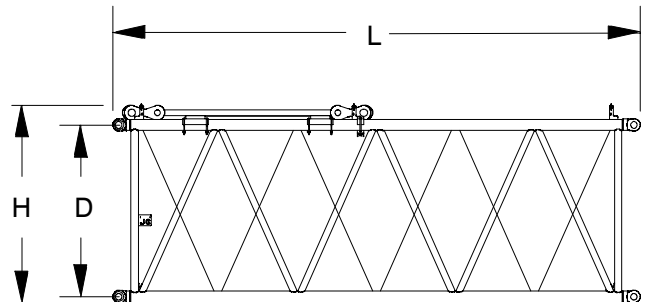
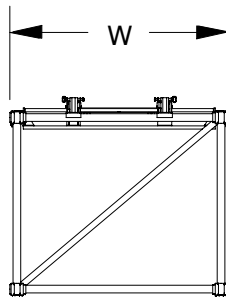

**20 ft (6.10m) Heavy Duty/  
Long Range Boom  
Tapered Extension “JR”** ①

Length	20 ft 5.5 in	(6.24m)
Width	8 ft 4.2 in	(2.55m)
Deep	80 in	(2.03m)
Height	7 ft 7.8 in	(2.33m)
Weight	5,044 lb	(2 288kg)

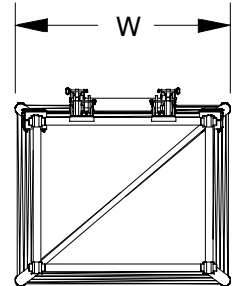
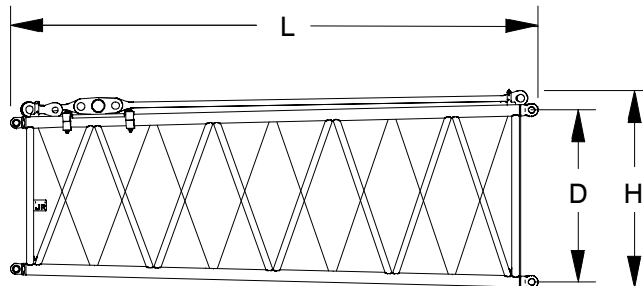

Number inside black circle “①” = # of components

\* – Optional equipment

### 15 ft (4.57m) Heavy Duty Boom Top Section “N” ①

Length 1	17 ft 5.3 in	(5.32m)
Length 2	17 ft 6.4 in	(5.34m)
Width	7 ft 2 in	(2.18m)
Deep	68 in	(1.72m)
Height 1	7 ft 5.4 in	(2.27m)
Height 2	7 ft 4.5 in	(2.25m)
Weight	7,526 lb	(3 414kg)

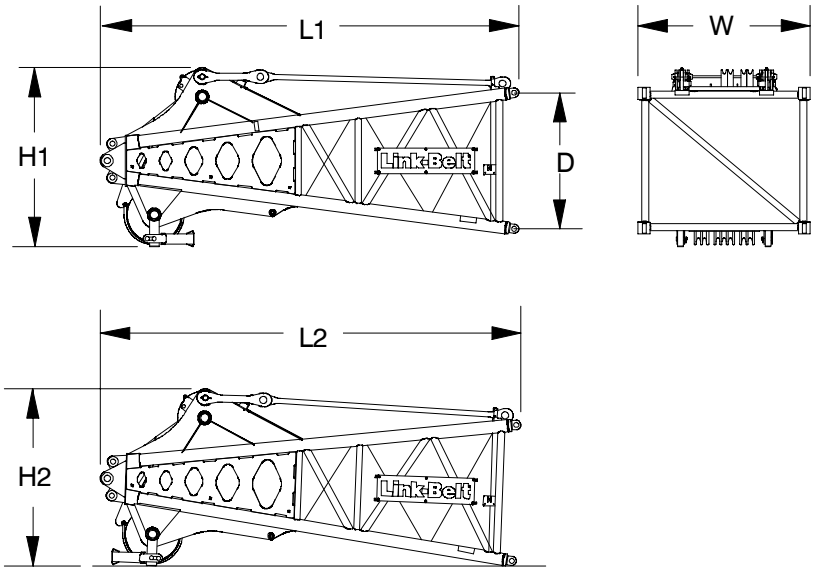

### 30 ft (9.14m) Long Range Boom Top Section “G” ①

Length 1	33 ft 10.8 in	(10.33m)
Length 2	33 ft 11.8 in	(10.36m)
Width	7 ft 0 in	(2.03m)
Deep	68 in	(1.72m)
Height 1	7 ft 2.4 in	(2.19m)
Height 2	7 ft 0.1 in	(2.14m)
Weight	5,072 lb	(2 301kg)

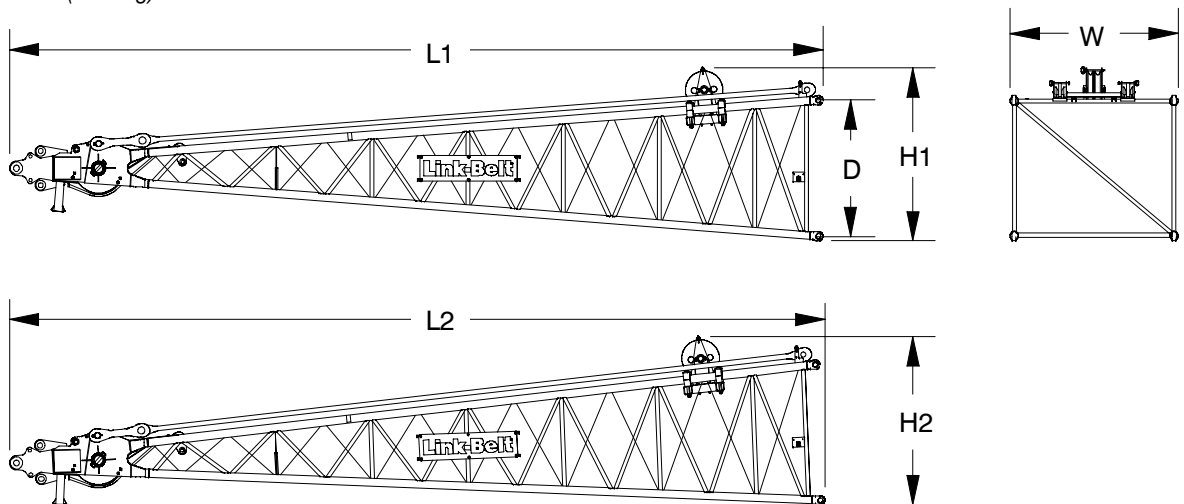

Number inside black circle “①” = # of components

\* – Optional equipment

# Jib/Fixed Jib

## 20 ft (6.10m) Jib/Fixed

### Top Section “E”\*

①

Length	22 ft 2.2 in	(6.76m)
Width	48 in	(1.21m)
Deep	39 in	(0.99m)
Height	4 ft 1.3 in	(1.25m)
Weight	1,755 lb	(796kg)

Weight includes jib top, 23 in (0.58m) head sheave, pendant links, ATB weight, and mounting hardware.

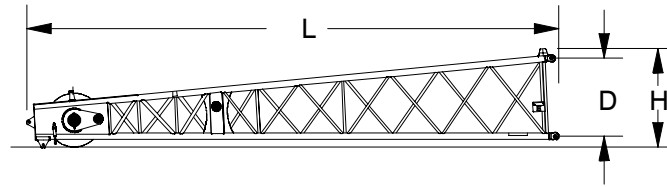

## 20 ft (6.10m) Jib/Fixed

### Base Section “K”\*

①

Length	21 ft 2 in	(6.41m)
Width	48 in	(1.21m)
Deep	39 in	(0.99m)
Height	5 ft 10.4 in	(1.79m)
Weight	2,936 lb	(1 332kg)

Weight includes base section, strut, pendants, and mounting hardware.

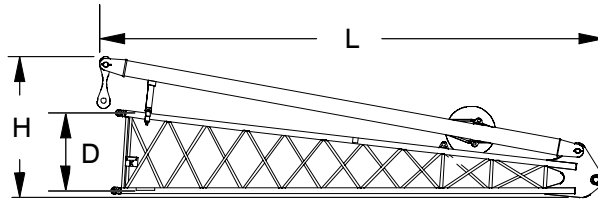

## 20 ft (6.10m) Jib/Fixed

### Extensions “EF”\*

Length	20 ft 3.5 in	(6.19m)
Width	48 in	(1.21m)
Deep	39 in	(0.99m)
Height	3 ft 7.9 in	(1.11m)
Weight	959 lb	(435kg)

Weights includes extension, pendants, wear bar, and mounting hardware.

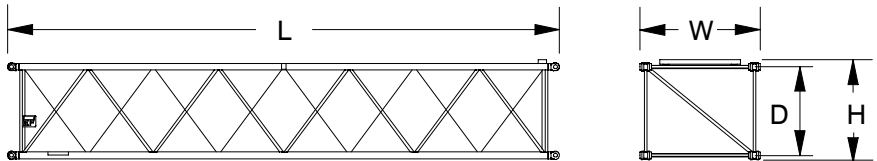

Number inside black circle “①” = # of components

\* – Optional equipment

# Luffing Jib

## Luffing Jib Extensions\*

Weights Include Pendants and Hardware

### 10 ft (3.05m) Extension

Weight: 1,338 lb (607kg)

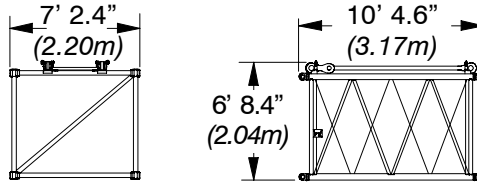

### 20 ft (6.10m) Extension

Weight: 2,162 lb (981kg)

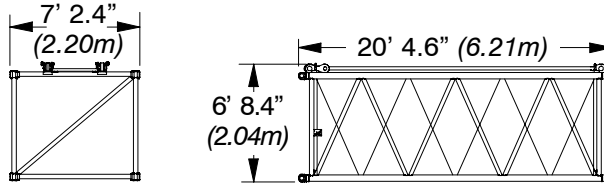

### 30 ft (9.14m) Extension

Weight: 2,992 lb (1 357kg)

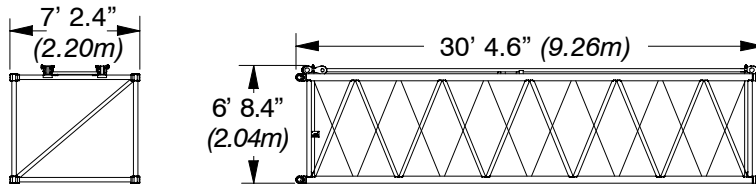

### 40 ft (12.19m) Extension

Weight: 3,823 lb (1 734kg)

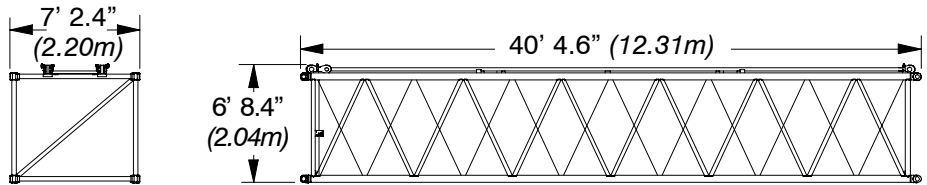

## 30 ft (9.14m) Luffing Jib Top Section\*

Length 1	33 ft 10.8 in	(10.33m)
Length 2	33 ft 11.8 in	(10.36m)
Width	7 ft 0 in	(2.03m)
Deep	68 in	(1.72m)
Height 1	7 ft 2.4 in	(2.19m)
Height 1	7 ft 0.1 in	(2.14m)
Weight	5,072 lb	(2 301kg)

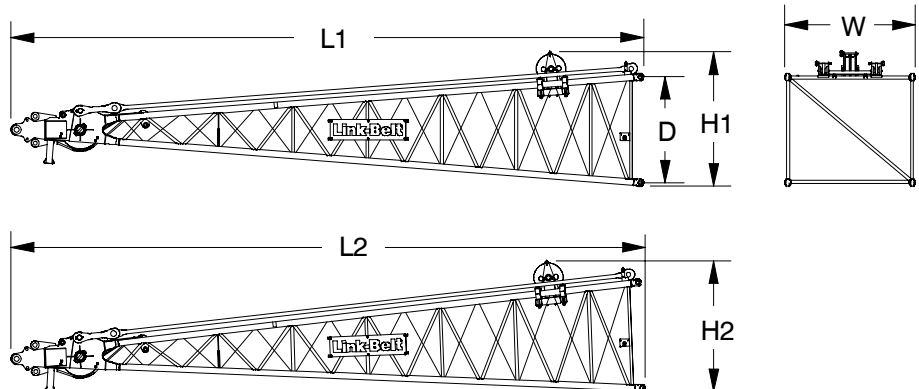

## Luffing Jib Base Section\*

Length	36 ft 9.44 in	(11.21m)
Width	7ft 2.4 in	(2.20m)
Height	12 ft 5.38 in	(3.79m)
Weight†	19,200 lb	(8 709kg)

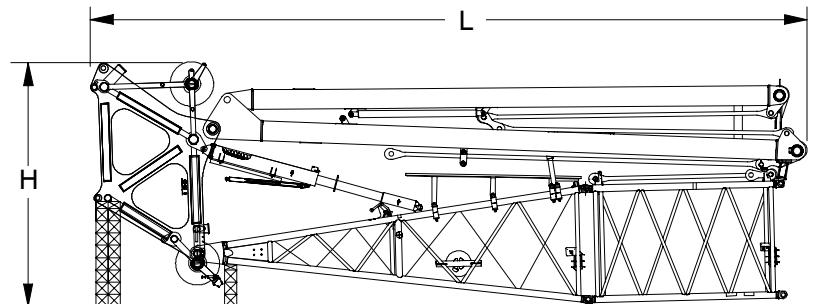

Number inside black circle "1" = # of components

\* – Optional equipment

# Hook Balls

## 20 Ton (18.1mt) Non-Swivel Hook Ball\* 1

Width	21.75 in	(0.55m)
Height	39.00 in	(0.99m)
Weight	1,214 lb	(551kg)

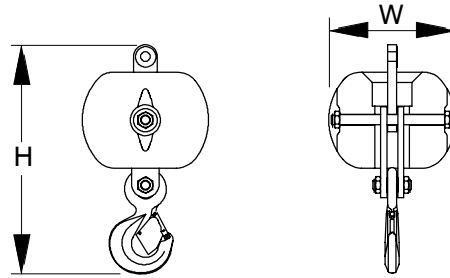

# Hook Blocks

## 60 Ton (54.4mt) 2-Sheave Hook Block\* 1

Width1	15.50 in	(0.39m)
Width2	28.75 in	(0.73m)
Width3	18.75 in	(0.48m)
Height	67.00 in	(1.70m)
Weight	1,637 lb	(742kg)

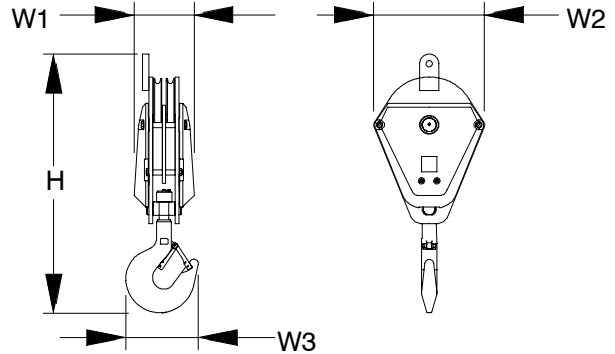

## 165 Ton (149.7mt) 5-Sheave Hook Block\* 1

Width1	22.00 in	(0.56m)
Width2	28.75 in	(0.73m)
Width3	28.25 in	(0.72m)
Height	81.50 in	(2.07m)
Weight	3,611 lb	(1 638kg)

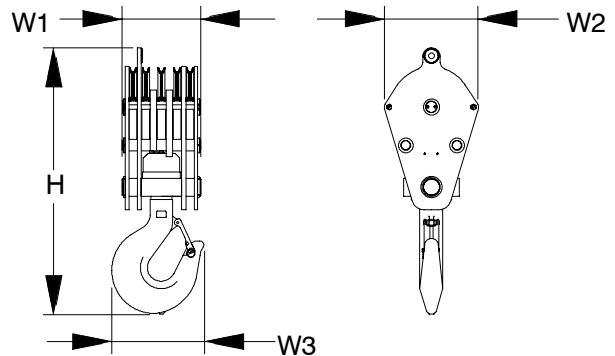

## 250 Ton (226.8mt) 6-Sheave Hook Block\* 1

Width1	25.35 in	(0.64m)
Width2	35.25 in	(0.90m)
Width3	34.75 in	(0.88m)
Height	95.35 in	(2.42m)
Weight	4,932 lb	(2 237kg)

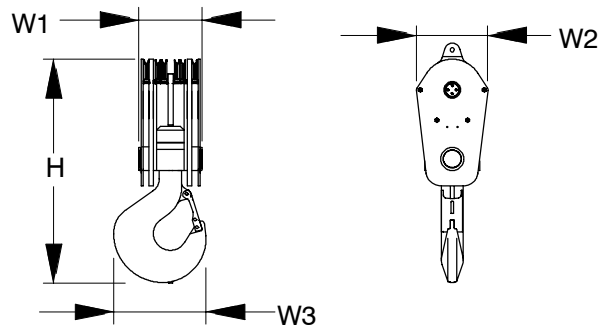

## 300 Ton (272.2mt) 7-Sheave Hook Block\* 1

Width1	31.00 in	(0.79m)
Width2	28.75 in	(0.73m)
Width3	37.25 in	(0.95m)
Height	96.25 in	(2.44m)
Weight	6,436 lb	(2 919kg)

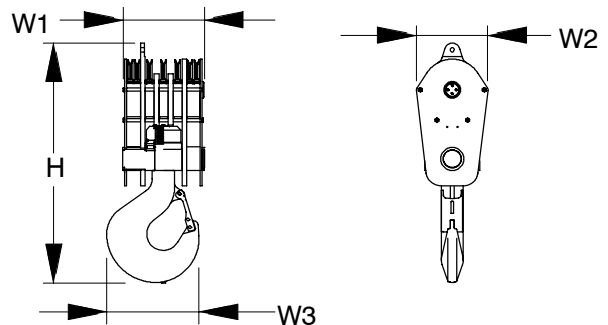

Number inside black circle "1" = # of components  
 \* – Optional equipment

# Assembly Diagram

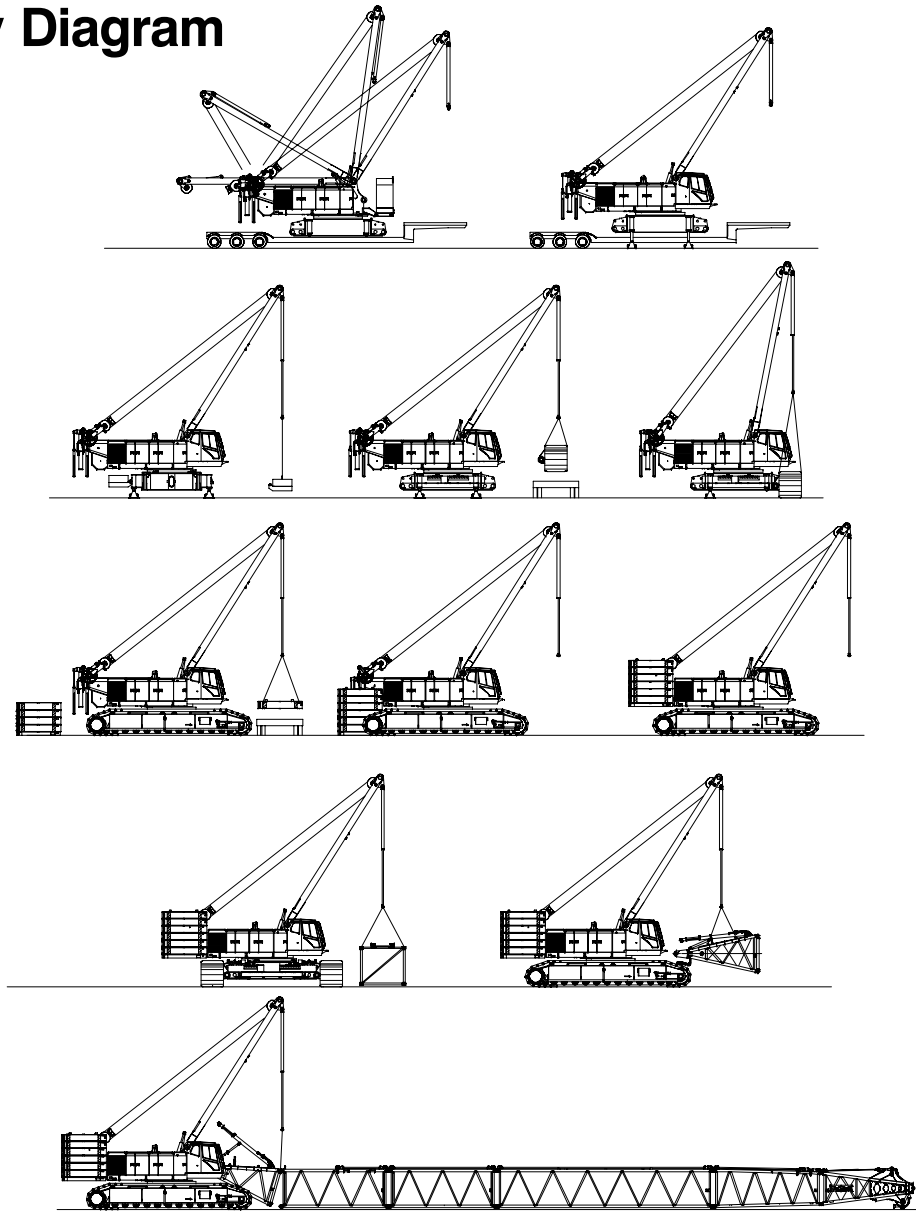

# Working Weights

Based on basic crane including Isuzu BB-6W1XQB-01 diesel engine, turntable bearing, independent hydraulic powered drums, boom hoist limit device, independent hydraulic swing and travel, counterweight, swing brake, drum rotation indicators, crawler lower with 50 in (1.27m) track shoes, sealed carrier rollers, catwalks, and hydraulic boom foot pin removal. The following are also included:

Lifting crane – Base machine with live mast, 1,230 ft (374.9m) main rope, 940 ft (286.5m) auxiliary rope, 70 ft (21.3m) basic heavy duty boom, and 50 in (1.27m) side frames.

		A+A Cwt	AB+A Cwt	ABC+A Cwt
		lb (kg)	lb (kg)	lb (kg)
		354,888 lb (160,974kg)	456,988 lb (207,286kg)	505,688 lb (229,376kg)
Ground Bearing Pressure	psi	10.5	13.5	15.0
	kg/cm <sup>2</sup>	0.74	0.95	1.05

# Transport Weights

Base Crane: Hydraulic backstops, 132 gal (500L) of fuel, carbody jacks, 32 ft (9.8m) live mast, bridle and bail with 24 – part boom hoist reeving, 1,230 ft (374.9m) type “LB” front drum rope, and 940 ft (286.5m) type “RB” rear drum rope.

Item Description	Gross Weight		Transport Loads									
	lb	(kg)	#1	#2	#3	#4	#5	#6	#7	#8	#9	#10
Base crane	95,900	43 500	1									
Add Side Frame (50” shoes) – Two required	45,000	20 412		1	1							
Add Upper “A” Base Ctw – Top	10,979	4 980						1				
Add Upper “A” Base Ctw – Bottom	25,149	11 407						1				
Add Upper “A” Wing Ctw – Two Required	17,086	5 897							2			
Add Upper “B” Wing Ctw – Six Required	16,755	7 600								2	2	2
Add Upper “C” Wing Ctw – Four Required	12,125	5 499										
Add Lower “A” Ctw – Two Required	11,243	5 100				1	1					
Add Lower “B” Ctw – Two Required	11,464	5 200				1	1					
Add Lower Base Ctw – Two Required	14,770	6 670				1	1					
Add 30 ft (9.14m) “G” Top Section	5,072	2 301										
Add 15 ft (4.57m) “N” Top Section	7,526	3 414						1				
Add 20 ft (6.10m) “JC” Extension With Pins And Pendants	3,651	1 656									1	
Add 30 ft (9.14m) “JC” Extension With Pins And Pendants	5,187	2 353				1						
Add 40 ft (12.19m) “JC” Extension With Pins And Pendants	6,552	2 972					1		1			
Add 15 ft (4.57m) “N” Base Section With Backstops	6,350	2 880								1		
Add 20 ft (6.10m) “JT” Base Extension	4,126	1 872								1		
Add 20 ft (6.10m) “JR” Tapered Extension	5,004	2 301									1	
Add 10 ft (3.05m) “FE” Extension With Pins And Pendants	1,338	607										
Add 20 ft (6.10m) “FE” Extension With Pins And Pendants	2,162	981										
Add 30 ft (9.14m) “FE” Extension With Pins And Pendants	2,992	1 357										
Add 40 ft (12.19m) “FE” Extension With Pins And Pendants	3,823	1 734										
Add 40 ft (12.19m) Jib	5,776	2 620										1
Add 20 ft (6.10m) Jib Extension	685	311						1				
Add 5 ft (1.52m) Auxiliary Tip Extension	671	304										
Add 20 Ton (18.1mt) Hook Ball	1,214	551							1			
Add 60 Ton (54.4mt) Hook Block	1,637	742				1						
Add 250 Ton (226.8mt) Hook Block	5,600	2 540										1
Add free fall to base crane	4,200	1 905										
Remove ctw removal system	3,700	1 678										
Remove carbody jacks	3,140	1 424										
Remove track spacers	1,000	454										
Add Hydraulic Third Drum Without Rope	990	449										
Remove Main Hoist Rope ]1.10 in (28mm) x 1,230 ft (374.9m)[	2,878	1 305										
Remove Auxiliary Wire Rope ]1.10 in (28mm) x 940 ft (286.5m)[	2,350	1 066										
Remove 50 Gal (189L) of Fuel	–362	–164										
Approximate Total Shipping Weight	lb		95,900	45,000	45,000	44,301	44,029	44,339	41,938	43,986	42,165	44,886
	kg		43 500	20 412	20 412	20 095	19 971	20 112	19 023	19 952	19 126	20 360

# Transport Drawings

200 + 60 ft (60.96 + 18.29m)  
with AB Counterweight

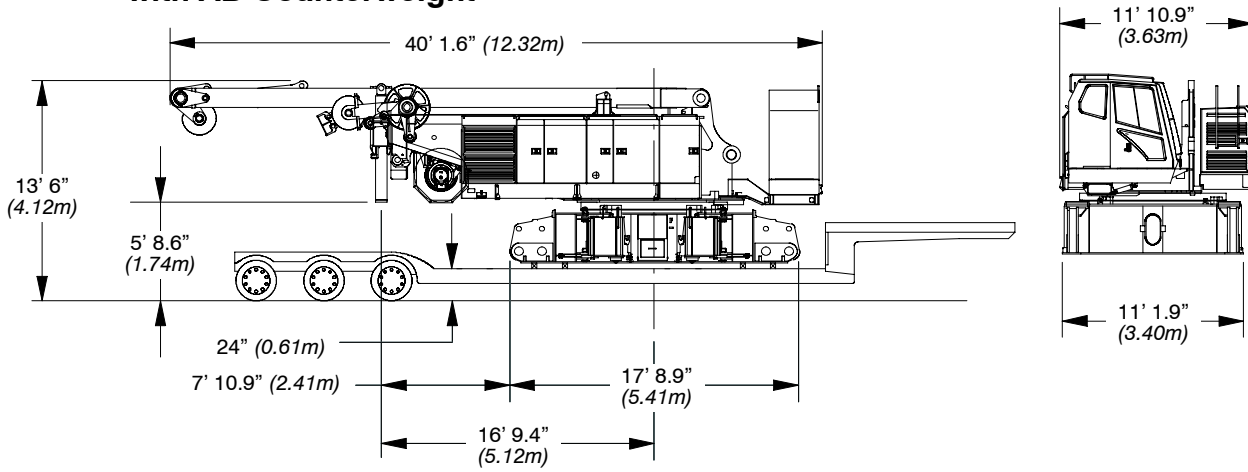

**LOAD #1 – 95,900 lb (43 500kg)**

Base crane

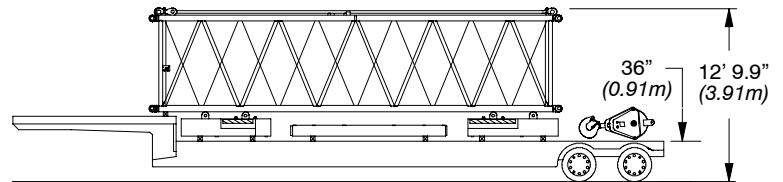

**LOAD #4 – 44,301 lb (20 095kg)**

Lower "A" counterweight, lower "B" counterweight, lower base counterweight, 30 ft (9.14m) "JC" boom extension with pins and pendants, and 60 Ton (54.4mt) hook block

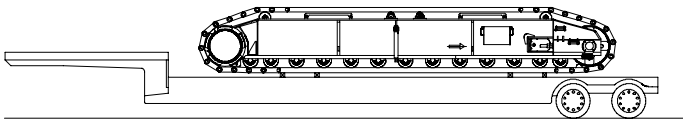

**LOAD #2 – 45,000 lb (20 412kg)**

Side frame with wedge pack

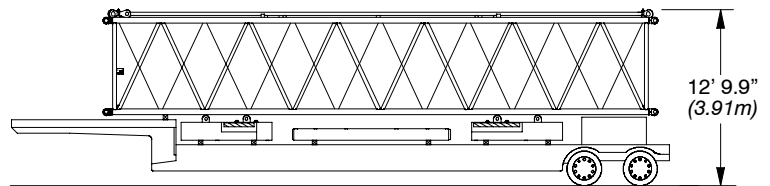

**LOAD #5 – 44,029 lb (19 971kg)**

Lower "A" counterweight, lower "B" counterweight, lower base counterweight, 40 ft (12.19m) and "JC" boom extension with pins and pendants

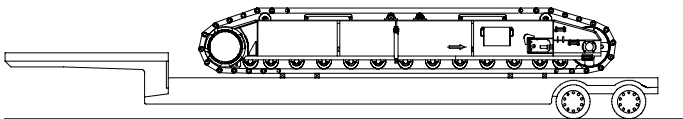

**LOAD #3 – 45,000 lb (20 412kg)**

Side frame with wedge pack

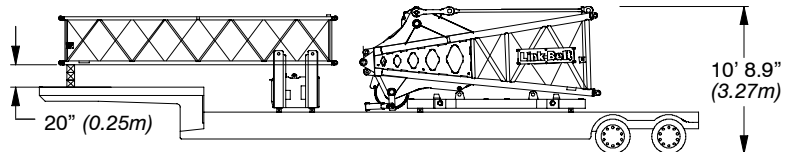

**LOAD #6 – 44,339 lb (20 112kg)**

Upper "A" base counterweight top, upper "A" base counterweight bottom, and 15 ft (4.57m) "N" boom top section, and 20 ft (4.57m) jib extension

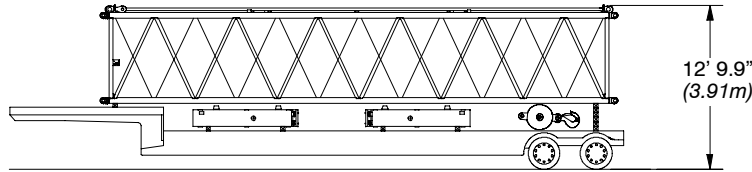

**LOAD #7 – 41,938 lb (19 023kg)**

Two “A” wing counterweights, 40 ft (12.19m) “JC” boom extension, and 20 Ton (18.1mt) hook ball

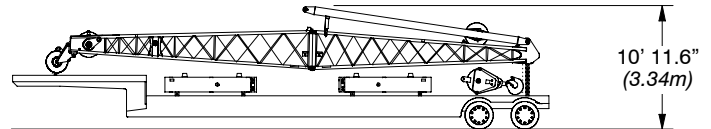

**LOAD #10 – 42,292 lb (19 183kg)**

Two “B” wing counterweights, 40 ft (12.19m) jib, and 250 Ton (226.8mt) hook block

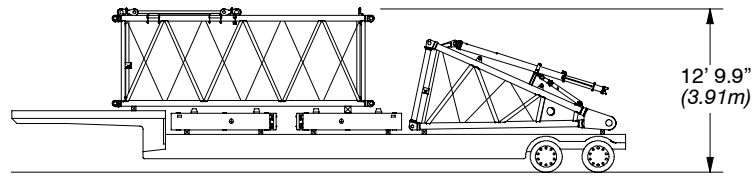

**LOAD #8 – 43,936 lb (19 929kg)**

Two “B” wing counterweights, 15 ft (4.57m) “N” base section with backstops, and 20 ft (6.10m) “JT” base extension

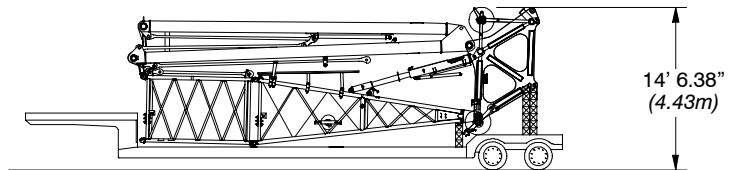

**LUFFER – 19,200 lb (8 709kg)**

Luffing boom cap, 20 ft (6.10m) luffing jib base, 10 ft (3.05m) luffing jib extension, luffing jib backstops, and fan post assembly

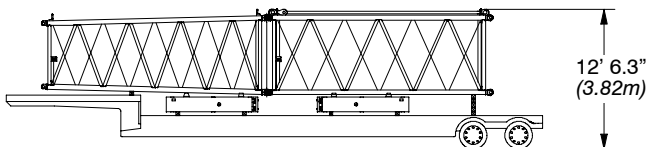

**LOAD #9 – 42,867 lb (19 444kg)**

Two “B” wing counterweights, 20 ft (6.10m) “JC” boom extension with pins and pendants, and 20 ft (6.10m) “JR” tapered boom extension

# Load Hoist Performance

## Front & Rear Drums – 1.10 in (28mm) Wire Rope

Rope Layer	Maximum Line Pull		No Load Line Speed		Full Load Line Speed		Pitch Diameter		Layer		Total	
	lb	kg	ft/min	m/min	ft/min	m/min	in	mm	ft	m	ft	m
1	54,269	24 616	353	107.5	142	43.1	23.8	604.5	174	53.1	174	53.1
2	49,660	22 525	385	117.4	155	47.1	26.0	660.4	189	57.6	363	110.7
3	45,771	20 761	418	127.4	168	51.1	28.2	716.3	204	62.1	567	172.6
4	42,466	19 262	451	137.4	181	55.1	30.4	772.2	219	66.6	786	239.4
5	39,589	17 957	483	147.3	194	59.1	32.6	828.0	233	71.1	1,019	310.5
6	37,071	16 815	516	157.3	207	63.1	34.8	883.9	248	75.6	1,267	386.1
7	34,868	15 816	549	167.2	220	67.1	37.0	939.8	262	80.0	1,529	466.1

## Boom Hoist Drum #1 (Right) – 1.02 in (26mm) Wire Rope

Rope Layer	Maximum Line Pull		No Load Line Speed		Full Load Line Speed		Pitch Diameter		Layer		Total	
	lb	kg	ft/min	m/min	ft/min	m/min	in	mm	ft	m	ft	m
1	37,742	17 120	86	26.2	78	23.8	22.0	558.8	57.6	17.6	57.6	17.6
2	34,350	15 581	94	28.7	85	25.9	24.1	612.1	62.5	19.0	120.1	36.6
3	31,822	14 434	102	31.1	92	28.0	26.1	662.9	67.4	20.5	187.5	57.1
4	29,508	13 385	110	33.5	99	30.2	28.1	713.7	72.3	22.0	259.8	79.2
5	27,507	12 477	118	36.0	107	32.6	30.2	767.1	77.1	23.5	336.9	102.7
6	25,761	11 685	126	38.4	114	34.7	32.2	817.9	82.0	25.0	418.9	127.7
7	24,223	10 988	134	40.8	121	36.9	34.3	871.2	86.9	26.5	505.8	154.2

## Boom Hoist Drum #2 (Left) – 1.02 in (26mm) Wire Rope

Rope Layer	Maximum Line Pull		No Load Line Speed		Full Load Line Speed		Pitch Diameter		Layer		Total	
	lb	kg	ft/min	m/min	ft/min	m/min	in	mm	ft	m	ft	m
1	38,641	17 528	84	25.6	76	23.2	21.5	546.1	56.3	17.2	56.3	17.2
2	35,281	16 003	92	28.0	83	25.3	23.5	596.9	61.2	18.6	117.4	35.8
3	32,458	14 723	100	30.5	91	27.7	25.6	650.2	66.0	20.1	183.5	55.9
4	30,054	13 632	108	32.9	98	29.9	27.6	701.0	70.9	21.6	254.4	77.5
5	27,981	12 692	116	35.4	105	32.0	29.7	754.4	75.8	23.1	330.2	100.6
6	26,176	11 873	124	37.8	112	34.1	31.7	805.2	80.7	24.6	410.9	125.2
7	24,590	11 154	132	40.2	120	36.6	33.8	858.5	85.6	26.1	496.4	151.3

## Third Hoist Drum – 0.87 in (22mm) Wire Rope

Rope Layer	Maximum Line Pull		No Load Line Speed		Full Load Line Speed		Pitch Diameter		Layer		Total	
	lb	kg	ft/min	m/min	ft/min	m/min	in	mm	ft	m	ft	m
1	32,907	14 926	240	73.0	228	69.5	21.6	548.6	67.8	20.7	67.8	20.7
2	30,440	13 807	259	78.9	246	75.1	23.1	586.7	72.8	22.2	140.7	42.9
3	28,317	12 844	278	84.9	265	80.8	24.6	624.8	77.8	23.7	218.5	66.6
4	26,471	12 007	298	90.8	283	86.4	26.1	662.9	83.0	25.3	301.4	91.9
5	24,851	11 272	317	96.7	302	92.0	27.7	703.6	87.9	26.8	389.3	118.7
6	23,418	10 622	337	102.6	320	97.7	29.2	741.7	92.8	28.3	482.2	147.0
7	22,141	10 043	356	108.5	339	103.3	30.7	779.8	97.8	29.8	580.0	176.8
8	20,996	9 524	375	114.5	357	108.9	32.3	820.4	103.0	31.4	682.9	208.2

Wire Rope Application	Diameter		Type	Max. Permissible Load		Wire Rope Descriptions
	in	mm		lb	kg	
Boom Hoist	1.02	26	FC	37,500	17 010	6 Strand, Compacted Strand, Swaged, Preformed, I.W.R.C., Right Lay, Regular Lay
Front Hoist	1.10	28	GC	47,600	21 591	4 strand, low torque, right regular lay
Rear Hoist	1.10	28	GC	47,600	21 591	4 strand, low torque, right regular lay
Third Drum	0.87	22	LB	25,000	11 340	6 x 25 (6 x19 Class) – Filler Wire – Preformed – I.W.R.C – Right Lay – Regular Lay Compacted Strands

# Working Areas

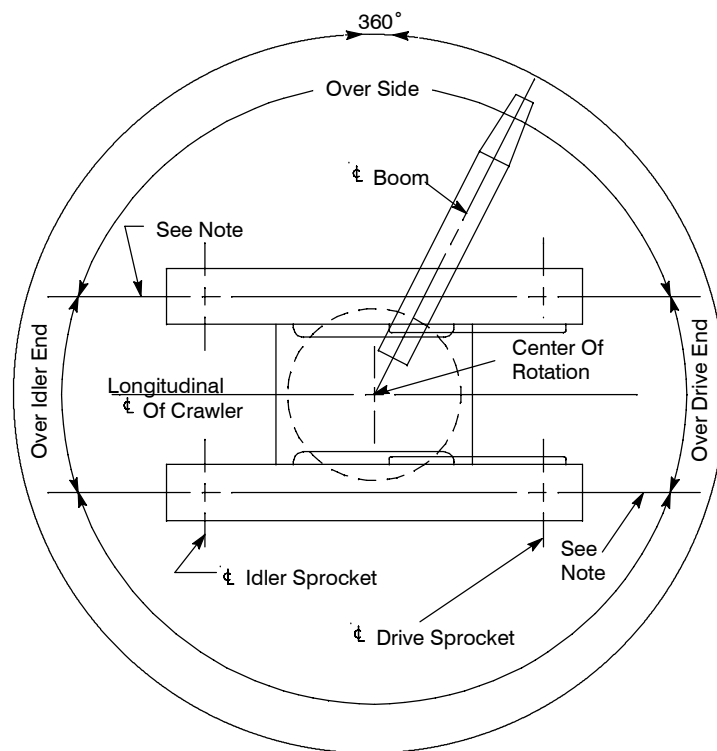

**Note:** These Lines Determine The Limiting Position Of Any Load For Operation Within Working Areas Indicated.

# Attachments

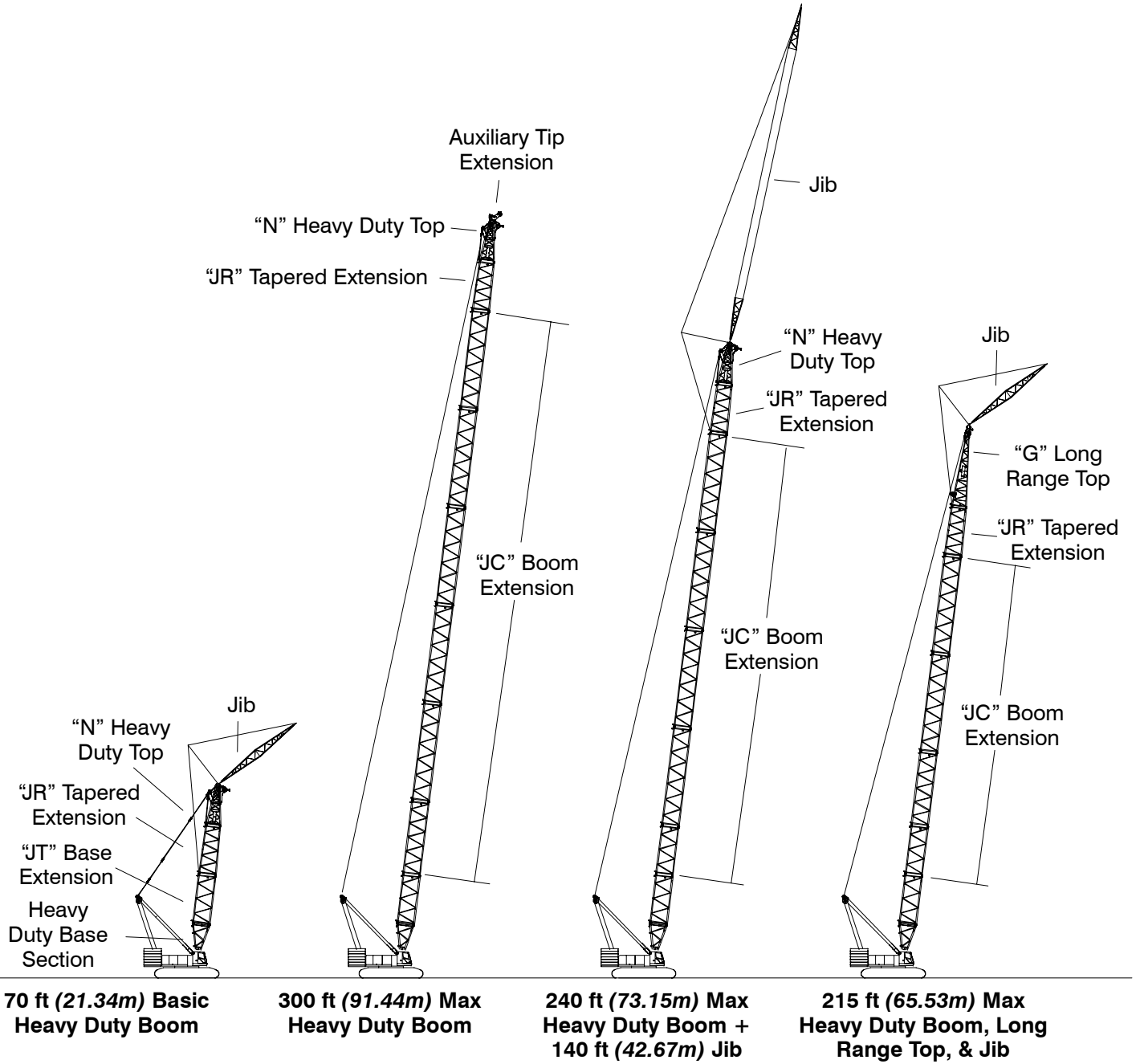

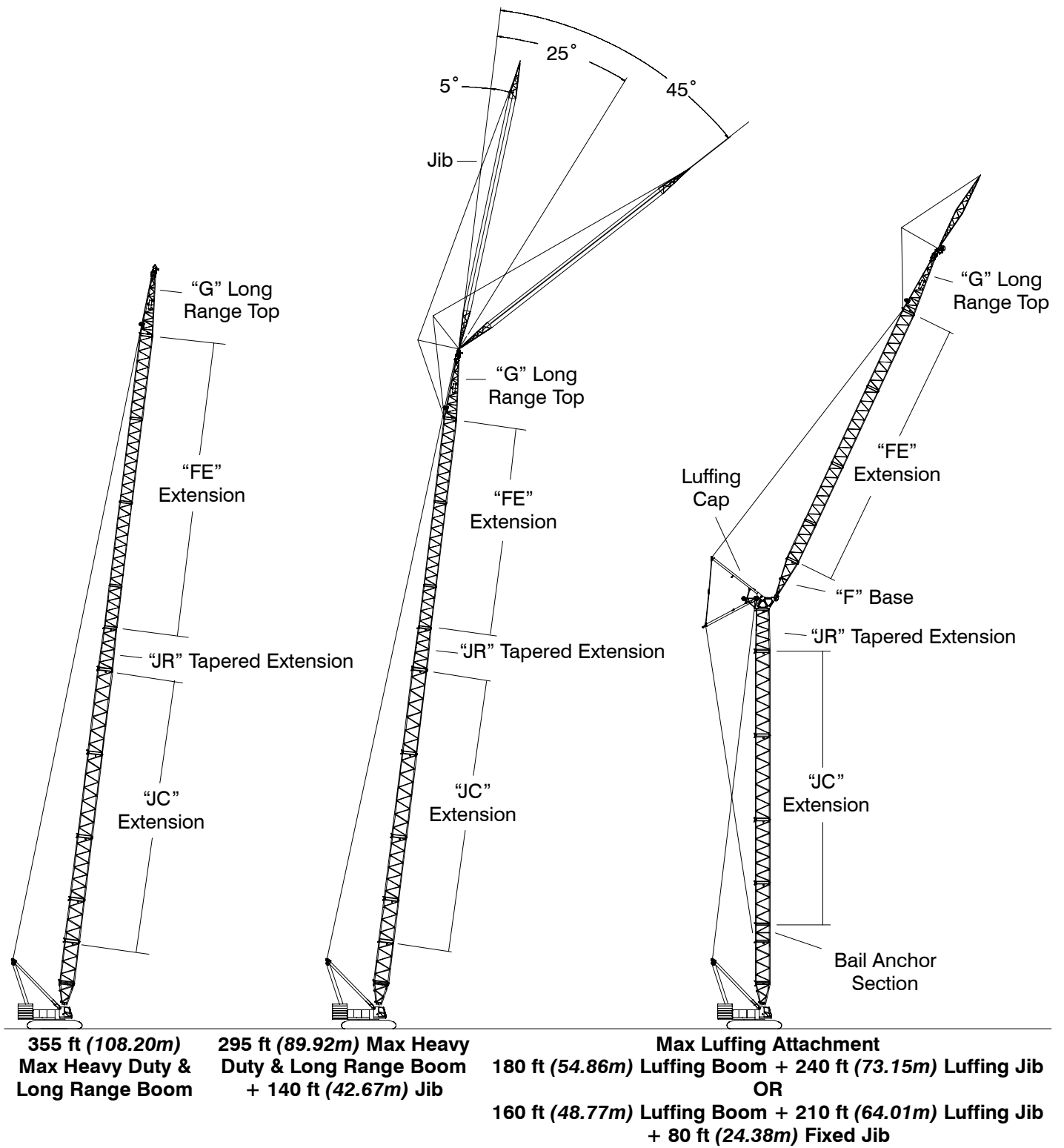

# Heavy Duty Boom

## Boom Make-Up

Boom Length ft (m)	Boom Extensions – ft (m)						
	15 (4.57) “N” Base	20 (6.10) “JT” Ext	20 (6.10) “JC” Ext	30 (9.14) “JC” Ext	40 (12.19) “JC” Ext	20 (6.10) “JR” Taper	15 (4.57) “N” Top
70 (21.34)	1	1				1	1
80 (24.38)	Not Recommended						
90 (27.43)	1	1	1			1	1
100 (30.48)	1	1		1		1	1
110 (33.53)	1	1			1	1	1
120 (36.58)	1	1	1	1		1	1
130 (39.62)	1	1	1		1	1	1
140 (42.67)	1	1		1	1	1	1
150 (45.72)	1	1			2	1	1
160 (48.77)	1	1	1	1	1	1	1
170 (51.82)	1	1	1		2	1	1
180 (54.86)	1	1		1	2	1	1
190 (57.91)	1	1			3	1	1
200 (60.96)	1	1	1	1	2	1	1
210 (64.01)	1	1	1		3	1	1
220 (67.06)	1	1		1	3	1	1
230 (70.10)	1	1	2		3	1	1
240 (73.15)	1	1	1	1	3	1	1
250 (76.20)	1	1	2	2	2	1	1
260 (79.25)	1	1	2	1	3	1	1
270 (82.30)	1	1	1	2	3	1	1
280 (85.34)	1	1	1	1	4	1	1
290 (88.39)	1	1	2	2	3	1	1
300 (91.44)	1	1	2	1	4	1	1

### Notes:

- Capacities shown are in kips/metric tons (1 kip = 1,000 lb / 1 metric ton = 0.45 kips) and are not more than 75% of the tipping loads with the crane standing level on firm supporting surface. A deduction must be made from these capacities for weight of hook block, hook ball, sling, grapple, load weighing device, etc. When using main hook while jib or tip extension is attached, reduce capacities by values shown in Crane Rating Manual. See Operator's Manual for all limitations when raising or lowering attachment.
- The capacities in the shaded areas are based on structural strength. The capacities in the non-shaded areas are based on stability ratings.
- For recommended reeving, parts of line, wire rope type, and wire rope inspection, see Wire Rope Capacity Chart, Operator's Manual, and Parts Manual.
- Load ratings are based on freely suspended loads and make no allowances for such factors as the effect of the wind, ground conditions, and operating speeds. The operator shall therefore reduce load ratings in order to take these conditions into account. Refer to the Crane Rating Manual for Wind Speed Restrictions.
- The 30 ft (9.14m) live mast must be used for all capacities listed.
- The least stable rated condition is over the side.
- Booms must be erected and lowered over the end for maximum stability.
- Main boom length must not exceed 300 ft (91.44m).
- Do not operate at radii and boom lengths where the Crane Rating Manual lists no capacity. Do not use longer booms or jibs than those listed in the Crane Rating Manual. Any of the above can cause a tipping condition, or boom and jib failure.
- These capacities are in compliance with ASME/ANSI B30.5 at date of manufacture.
- These capacities apply only to the crane as originally manufactured and normally equipped by Link-Belt Construction Equipment Company.

# Working Range Diagram – Extended Gauge

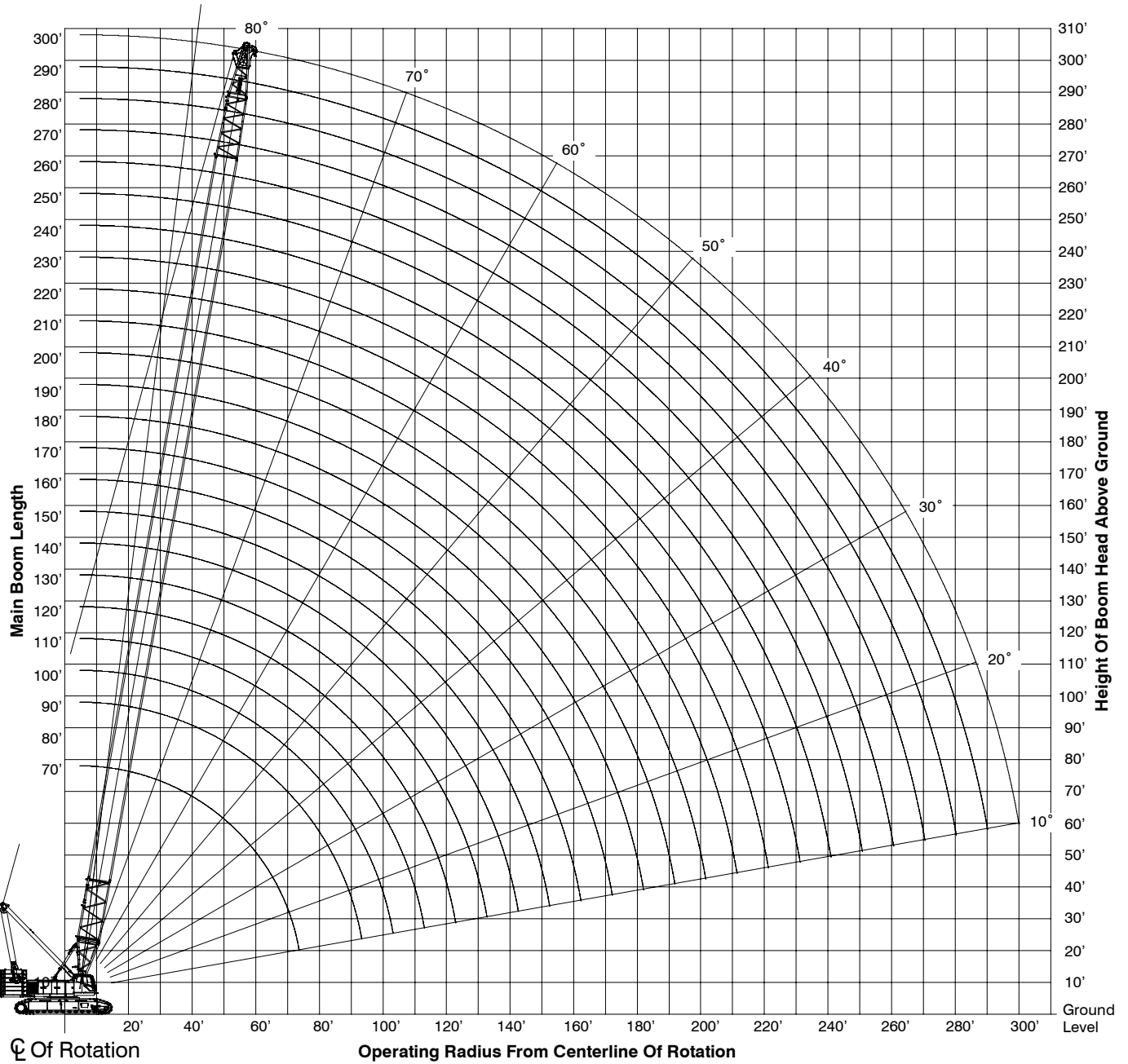

**Notes:**

1. Boom geometry shown is for unloaded condition and crane standing level on firm supporting surface. Boom deflection, subsequent radius, and boom angle change must be accounted for when applying load to hook.

# Load Chart – Extended Gauge

**Heavy Duty Boom With Heavy Duty Top – Extended Gauge (22') – 360° Rotation**  
**ABC + A [221,700 + 75,000 lb (100.3 + 34.0mt)] Cwt**  
 [All capacities are listed in kips (mt)]

Load Radius ft (m)	Boom Length ft (m)													Load Radius ft (m)		
	70 (21.34)	90 (27.43)	110 (33.53)	130 (39.62)	150 (45.72)	170 (51.82)	190 (57.91)	210 (64.01)	230 (70.10)	250 (76.20)	270 (82.30)	290 (88.39)	300 (91.44)			
16 (4.88)	600.0 (272.7)													16 (4.88)		
17 (5.18)	569.0 (258.6)													17 (5.18)		
18 (5.49)	539.8 (245.4)													18 (5.49)		
19 (5.79)	513.5 (233.4)	510.1 (231.9)												19 (5.79)		
20 (6.10)	489.4 (222.5)	486.4 (221.1)												20 (6.10)		
30 (9.14)	331.2 (150.5)	329.8 (149.9)	327.8 (149.0)	325.5 (148.0)	322.9 (146.8)	308.7 (140.3)								30 (9.14)		
40 (12.19)	235.1 (106.9)	235.6 (107.1)	235.5 (107.0)	235.2 (106.9)	234.8 (106.7)	234.4 (106.5)	233.9 (106.3)	225.3 (102.4)	186.9 (85.0)	153.4 (69.7)	128.5 (58.4)			40 (12.19)		
50 (15.24)	170.9 (77.7)	171.2 (77.8)	171.0 (77.7)	170.6 (77.5)	170.0 (77.3)	169.4 (77.0)	168.7 (76.7)	168.0 (76.4)	167.2 (76.0)	151.5 (68.9)	126.9 (57.7)	105.3 (47.9)	97.5 (44.3)	50 (15.24)		
60 (18.29)	132.9 (60.4)	133.3 (60.6)	133.0 (60.5)	132.4 (60.2)	131.8 (59.9)	131.0 (59.5)	130.2 (59.2)	129.4 (58.8)	128.6 (58.5)	127.8 (58.1)	118.2 (53.7)	100.0 (45.5)	92.6 (42.1)	60 (18.29)		
70 (21.34)	107.5 (48.9)	108.1 (49.1)	107.8 (49.0)	107.2 (48.7)	106.5 (48.4)	105.7 (48.0)	104.9 (47.7)	104.0 (47.3)	103.1 (46.9)	102.1 (46.4)	101.2 (46.0)	92.5 (42.0)	84.5 (38.4)	70 (21.34)		
80 (24.38)		90.1 (41.0)	89.9 (40.9)	89.4 (40.6)	88.6 (40.3)	87.8 (39.9)	86.9 (39.5)	85.9 (39.0)	85.0 (38.6)	83.9 (38.1)	82.9 (37.7)	82.0 (37.3)	75.5 (34.3)	80 (24.38)		
90 (27.43)		76.5 (34.8)	76.5 (34.8)	76.0 (34.5)	75.2 (34.2)	74.3 (33.8)	73.4 (33.4)	72.4 (32.9)	71.5 (32.5)	70.3 (32.0)	69.3 (31.5)	68.3 (31.0)	67.8 (30.8)	90 (27.43)		
100 (30.48)			66.0 (30.0)	65.6 (29.8)	64.8 (29.5)	63.9 (29.0)	63.0 (28.6)	62.0 (28.2)	61.0 (27.7)	59.8 (27.2)	58.7 (26.7)	57.7 (26.2)	57.2 (26.0)	100 (30.48)		
110 (33.53)			57.5 (26.1)	57.2 (26.0)	56.5 (25.7)	55.6 (25.3)	54.7 (24.9)	53.7 (24.4)	52.6 (23.9)	51.3 (23.3)	50.3 (22.9)	49.3 (22.4)	48.7 (22.1)	110 (33.53)		
120 (36.58)				50.3 (22.9)	49.7 (22.6)	48.8 (22.2)	47.9 (21.8)	46.8 (21.3)	45.8 (20.8)	44.5 (20.2)	43.4 (19.7)	42.4 (19.3)	41.8 (19.0)	120 (36.58)		
130 (39.62)				44.5 (20.2)	44.0 (20.0)	43.1 (19.6)	42.2 (19.2)	41.2 (18.7)	40.1 (18.2)	38.8 (17.6)	37.7 (17.1)	36.6 (16.6)	36.1 (16.4)	130 (39.62)		
140 (42.67)					39.1 (17.8)	38.3 (17.4)	37.4 (17.0)	36.4 (16.5)	35.3 (16.0)	33.9 (15.4)	32.8 (14.9)	31.8 (14.5)	31.2 (14.2)	140 (42.67)		
150 (45.72)					34.8 (15.8)	34.1 (15.5)	33.2 (15.1)	32.2 (14.6)	31.2 (14.2)	29.8 (13.5)	28.7 (13.0)	27.6 (12.5)	27.0 (12.3)	150 (45.72)		
160 (48.77)						30.5 (13.9)	29.6 (13.5)	28.6 (13.0)	27.6 (12.5)	26.2 (11.9)	25.1 (11.4)	24.0 (10.9)	23.4 (10.6)	160 (48.77)		
170 (51.82)							27.2 (12.4)	26.5 (12.0)	25.5 (11.6)	24.4 (11.1)	23.0 (10.5)	21.9 (10.0)	20.8 (9.5)	20.3 (9.2)	170 (51.82)	
180 (54.86)								23.6 (10.7)	22.7 (10.3)	21.7 (9.9)	20.2 (9.2)	19.1 (8.7)	18.0 (8.2)	17.5 (8.0)	180 (54.86)	
190 (57.91)									21.0 (9.5)	20.2 (9.2)	19.2 (8.7)	17.7 (8.0)	16.7 (7.6)	15.6 (7.1)	15.0 (6.8)	190 (57.91)
200 (60.96)										17.9 (8.1)	16.9 (7.7)	15.5 (7.0)	14.4 (6.5)	13.3 (6.0)	12.8 (5.8)	200 (60.96)
220 (67.06)											13.0 (5.9)	11.6 (5.3)	10.6 (4.8)	9.5 (4.3)	8.9 (4.0)	220 (67.06)
240 (73.15)												8.4 (3.8)	7.4 (3.4)	6.3 (2.9)	5.8 (2.6)	240 (73.15)
260 (79.25)													4.6 (2.1)	3.6 (1.6)	3.1 (1.4)	260 (79.25)
270 (82.30)													4.6 (2.1)	3.6 (1.6)		270 (82.30)

This material is supplied for reference use only. Operator must refer to in-cab Crane Rating Manual and Operator's Manual to determine allowable crane lifting capacities and assembly and operating procedures.

# Working Range Diagram – Retracted Gauge

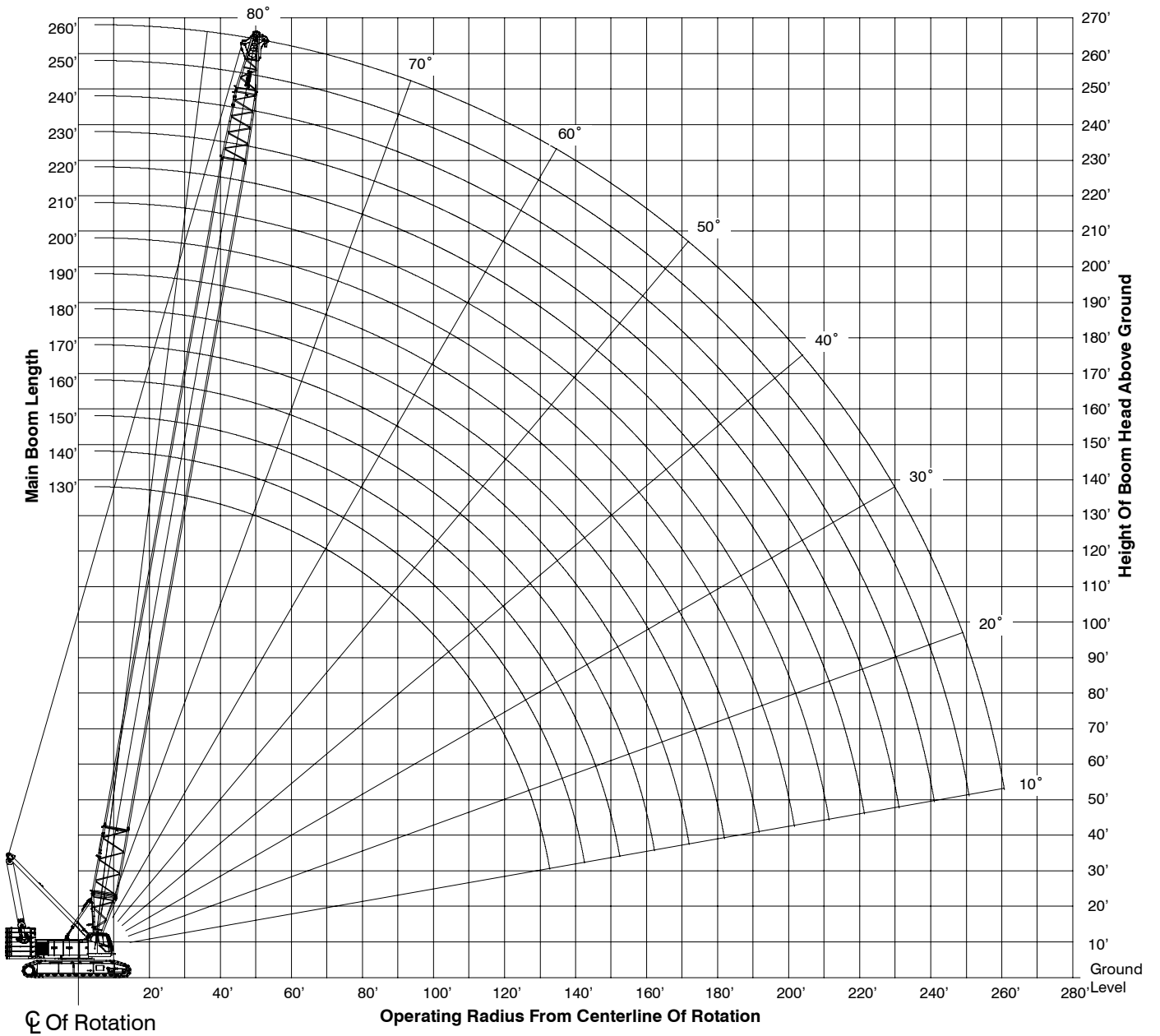

**Notes:**

1. Boom geometry shown is for unloaded condition and crane standing level on firm supporting surface. Boom deflection, subsequent radius, and boom angle change must be accounted for when applying load to hook.

# Load Chart – Retracted Gauge

Heavy Duty Boom With Heavy Duty Top – Retracted Gauge (19' 2") – 360° Rotation															
[All capacities are listed in kips (mt)]															
Load Radius ft (m)	Boom Length ft (m)													Load Radius ft (m)	
	AB + A [172,150 + 75,000 lb (78.1 + 34.0mt)] Ctwrt						ABC + A [221,700 + 75,000 lb (100.3 + 34.0mt)] Ctwrt								
	70 (21.34)	90 (27.43)	110 (33.53)	130 (39.62)	150 (45.72)	170 (51.82)	190 (57.91)	210 (64.01)	230 (70.10)	250 (76.20)	270 (82.30)	290 (88.39)	300 (91.44)		
16 (4.88)	561.7 (255.3)													16 (4.88)	
17 (5.18)	531.4 (241.5)													17 (5.18)	
18 (5.49)	504.1 (229.1)													18 (5.49)	
19 (5.79)	479.4 (217.9)	476.4 (216.5)												19 (5.79)	
20 (6.10)	456.9 (207.7)	454.2 (206.5)												20 (6.10)	
30 (9.14)	268.7 (122.1)	269.3 (122.4)	269.5 (122.5)	269.4 (122.5)	269.3 (122.4)	308.7 (140.3)								30 (9.14)	
40 (12.19)	175.3 (79.7)	175.6 (79.8)	175.4 (79.7)	175.1 (79.6)	174.6 (79.4)	205.6 (93.5)	205.0 (93.2)	204.4 (92.9)	186.9 (85.0)	153.4 (69.7)	128.5 (58.4)			40 (12.19)	
50 (15.24)	128.3 (58.3)	128.5 (58.4)	128.2 (58.3)	127.7 (58.0)	127.0 (57.7)	150.0 (68.2)	149.3 (67.9)	148.5 (67.5)	147.7 (67.1)	147.1 (66.9)	126.9 (57.7)	105.3 (47.9)	97.5 (44.3)	50 (15.24)	
60 (18.29)	99.8 (45.4)	100.1 (45.5)	99.8 (45.4)	99.2 (45.1)	98.4 (44.7)	116.6 (53.0)	115.8 (52.6)	114.9 (52.2)	114.0 (51.8)	113.2 (51.5)	112.3 (51.0)	100.0 (45.5)	92.6 (42.1)	60 (18.29)	
70 (21.34)	80.5 (36.6)	81.1 (36.9)	80.7 (36.7)	80.1 (36.4)	79.3 (36.0)	94.3 (42.9)	93.4 (42.5)	92.5 (42.0)	91.5 (41.6)	90.5 (41.1)	89.6 (40.7)	88.6 (40.3)	84.5 (38.4)	70 (21.34)	
80 (24.38)		67.3 (30.6)	67.1 (30.5)	66.4 (30.2)	65.7 (29.9)	78.3 (35.6)	77.4 (35.2)	76.4 (34.7)	75.4 (34.3)	74.3 (33.8)	73.3 (33.3)	72.3 (32.9)	71.8 (32.6)	80 (24.38)	
90 (27.43)		56.7 (25.8)	56.7 (25.8)	56.2 (25.5)	55.4 (25.2)	66.3 (30.1)	65.4 (29.7)	64.4 (29.3)	63.4 (28.8)	62.2 (28.3)	61.1 (27.8)	60.1 (27.3)	59.6 (27.1)	90 (27.43)	
100 (30.48)			48.6 (22.1)	48.1 (21.9)	47.3 (21.5)	57.0 (25.9)	56.0 (25.5)	55.0 (25.0)	54.0 (24.5)	52.7 (24.0)	51.6 (23.5)	50.6 (23.0)	50.1 (22.8)	100 (30.48)	
110 (33.53)			41.9 (19.0)	41.6 (18.9)	40.9 (18.6)	49.5 (22.5)	48.5 (22.0)	47.5 (21.6)	46.4 (21.1)	45.1 (20.5)	44.0 (20.0)	43.0 (19.5)	42.4 (19.3)	110 (33.53)	
120 (36.58)				36.2 (16.5)	35.6 (16.2)	43.3 (19.7)	42.3 (19.2)	41.3 (18.8)	40.2 (18.3)	38.9 (17.7)	37.8 (17.2)	36.7 (16.7)	36.2 (16.5)	120 (36.58)	
130 (39.62)				31.6 (14.4)	31.1 (14.1)	38.2 (17.4)	37.2 (16.9)	36.2 (16.5)	35.1 (16.0)	33.7 (15.3)	32.6 (14.8)	31.5 (14.3)	31.0 (14.1)	130 (39.62)	
140 (42.67)					27.2 (12.4)	33.8 (15.4)	32.8 (14.9)	31.8 (14.5)	30.7 (14.0)	29.3 (13.3)	28.2 (12.8)	27.1 (12.3)	26.5 (12.0)	140 (42.67)	
150 (45.72)					23.8 (10.8)	30.0 (13.6)	29.0 (13.2)	28.0 (12.7)	26.9 (12.2)	25.5 (11.6)	24.4 (11.1)	23.3 (10.6)	22.7 (10.3)	150 (45.72)	
160 (48.77)						26.6 (12.1)	25.8 (11.7)	24.7 (11.2)	23.7 (10.8)	22.2 (10.1)	21.1 (9.6)	20.0 (9.1)	19.5 (8.9)	160 (48.77)	
170 (51.82)							23.6 (10.7)	22.8 (10.4)	21.9 (10.0)	20.8 (9.5)	19.4 (8.8)	18.3 (8.3)	17.1 (7.8)	16.6 (7.5)	170 (51.82)
180 (54.86)								20.2 (9.2)	19.3 (8.8)	18.3 (8.3)	16.8 (7.6)	15.7 (7.1)	14.6 (6.6)	14.0 (6.4)	180 (54.86)
190 (57.91)								17.8 (8.1)	17.0 (7.7)	16.0 (7.3)	14.5 (6.6)	13.4 (6.1)	12.3 (5.6)	11.7 (5.3)	190 (57.91)
200 (60.96)									14.9 (6.8)	13.9 (6.3)	12.5 (5.7)	11.4 (5.2)	10.3 (4.7)	9.7 (4.4)	200 (60.96)
220 (67.06)										10.4 (4.7)	8.9 (4.0)	7.9 (3.6)	6.8 (3.1)	6.2 (2.8)	220 (67.06)
240 (73.15)											5.9 (2.7)	4.9 (2.2)	3.8 (1.7)	3.3 (1.5)	240 (73.15)
250 (76.20)											4.5 (2.0)	3.6 (1.6)	2.5 (1.1)	2.0 (0.9)	250 (76.20)
260 (79.25)												2.4 (1.1)			260 (79.25)

This material is supplied for reference use only. Operator must refer to in-cab Crane Rating Manual and Operator's Manual to determine allowable crane lifting capacities and assembly and operating procedures.

# Long Range Boom

## Boom Make-Up

Boom Length ft (m)	Boom Extensions – ft (m)										
	15 (4.57) "N" Base	20 (6.10) "JT" Base Ext	20 (6.10) "JC" Ext	30 (9.14) "JC" Ext	40 (12.19) "JC" Ext	20 (6.10) "JR" Tapered	10 (3.05) "FE" Ext	20 (6.10) "FE" Ext	30 (9.14) "FE" Ext	40 (12.19) "FE" Ext	30 (9.14) "G" Top
85 (25.91)	1	1				1					1
95 (28.96)	Not Recommended										
105 (32.00)	1	1	1			1					1
115 (35.05)	1	1		1		1					1
125 (38.10)	1	1			1	1					1
135 (41.15)	1	1	1	1		1					1
145 (44.20)	1	1	1		1	1					1
155 (47.24)	1	1		1	1	1					1
165 (50.29)	1	1			2	1					1
175 (53.34)	1	1	1	1	1	1					1
185 (56.39)	1	1	1		2	1					1
195 (59.44)	1	1		1	2	1					1
205 (62.48)	Not Recommended										
215 (65.53)	1	1	1	1	2	1					1
225 (68.58)	1	1	1	1	2	1	1				1
235 (71.63)	1	1	1	1	2	1		1			1
245 (74.68)	1	1	1	1	2	1			1		1
255 (77.72)	1	1	1	1	2	1				1	1
265 (80.77)	1	1	1	1	2	1	1			1	1
275 (83.82)	1	1	1	1	2	1		1		1	1
285 (86.87)	1	1	1	1	2	1			1	1	1
295 (89.92)	1	1	1	1	2	1				2	1
305 (92.96)	1	1	1	1	2	1	1			2	1
315 (96.01)	1	1	1	1	2	1		1		2	1
325 (99.06)	1	1	1	1	2	1			1	2	1
335 (102.11)	1	1	1	1	2	1	1		1	2	1
345 (105.16)	1	1	1	1	2	1		1	1	2	1
355 (108.20)	1	1	1	1	2	1	1	1	1	2	1

### Notes:

- Capacities shown are in kips/metric tons (1 kip = 1,000 lb / 1 metric ton = 0.45 kips) and are not more than 75% of the tipping loads with the crane standing level on firm supporting surface. A deduction must be made from these capacities for weight of hook block, hook ball, sling, grapple, load weighing device, etc. When using main hook while jib or tip extension is attached, reduce capacities by values shown in Crane Rating Manual. See Operator's Manual for all limitations when raising or lowering attachment.
- The capacities in the shaded areas are based on structural strength. The capacities in the non-shaded areas are based on stability ratings.
- For recommended reeving, parts of line, wire rope type, and wire rope inspection, see Wire Rope Capacity Chart, Operator's Manual, and Parts Manual.
- Load ratings are based on freely suspended loads and make no allowances for such factors as the effect of the wind, ground conditions, and operating speeds. The operator shall therefore reduce load ratings in order to take these conditions into account. Refer to the Crane Rating Manual for Wind Speed Restrictions.
- The 30 ft (9.14m) live mast must be used for all capacities listed.
- The least stable rated condition is over the side.
- Booms must be erected and lowered over the end for maximum stability.
- Main boom length must not exceed 355 ft (108.20m).
- Do not operate at radii and boom lengths where the Crane Rating Manual lists no capacity. Do not use longer booms or jibs than those listed in the Crane Rating Manual. Any of the above can cause a tipping condition, or boom and jib failure.
- These capacities are in compliance with ASME/ANSI B30.5 at date of manufacture.
- These capacities apply only to the crane as originally manufactured and normally equipped by Link-Belt Construction Equipment Company.

# Working Range Diagram – Extended Gauge

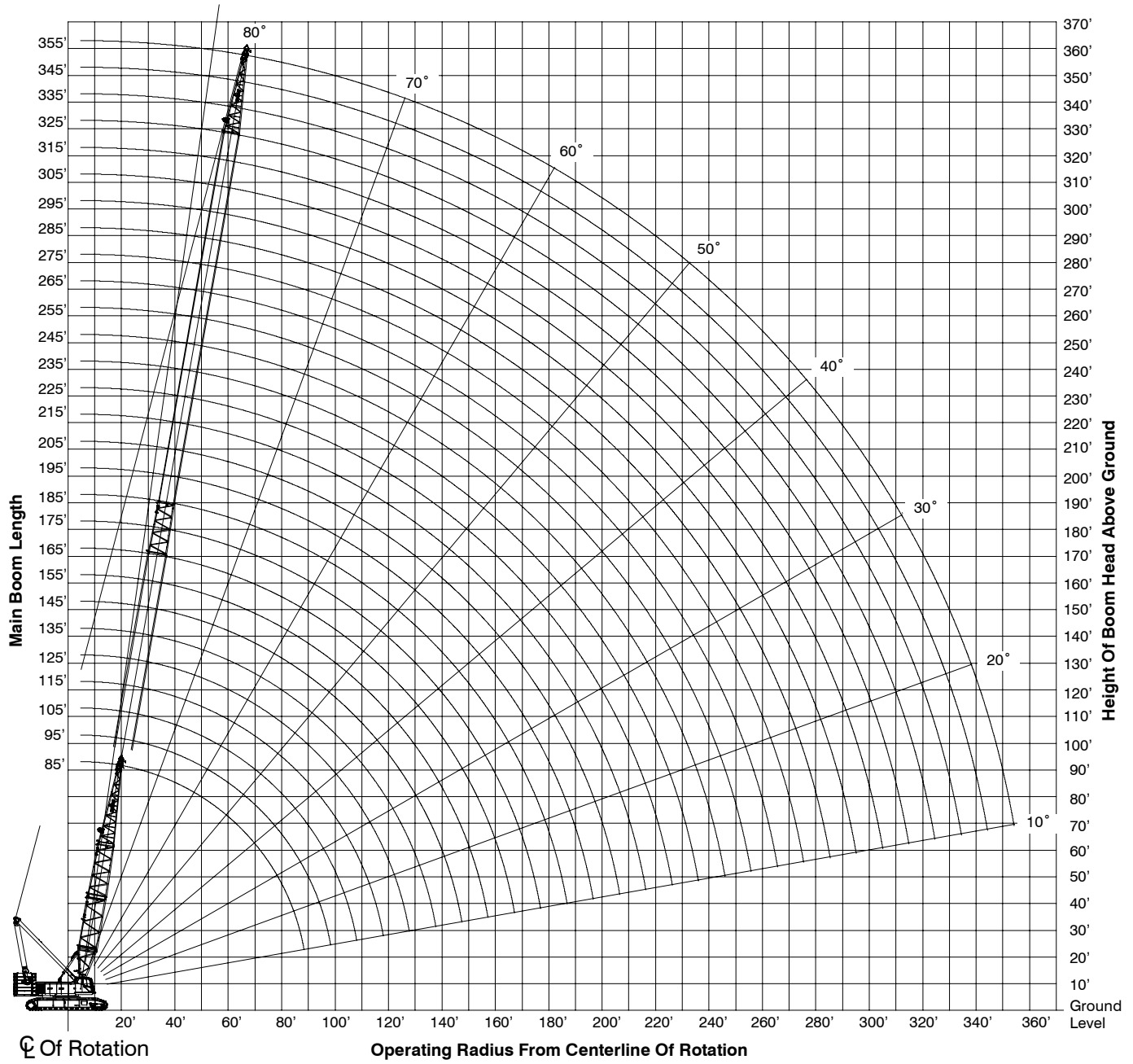

**Notes:**

1. Boom geometry shown is for unloaded condition and crane standing level on firm supporting surface. Boom deflection, subsequent radius, and boom angle change must be accounted for when applying load to hook.

# Load Chart – Extended Gauge

Long Range Top – Extended Gauge (22') – 360° Rotation  
 ABC + A [221,700 + 75,000 lb (100.3 + 34.0mt)] Cwt  
 [All capacities are listed in kips (mt)]

Load Radius ft (m)	Boom Length ft (m)														Load Radius ft (m)	
	85 (25.91)	105 (32.00)	125 (38.10)	145 (44.20)	165 (50.29)	185 (56.39)	205 (62.48)	225 (68.58)	245 (74.68)	265 (80.77)	285 (86.87)	305 (92.96)	325 (99.06)	345 (105.2)		355 (108.2)
17 (5.18)	302.2 (137.4)															17 (5.18)
18 (5.49)	296.5 (134.8)															18 (5.49)
19 (5.79)	290.9 (132.2)															19 (5.79)
20 (6.10)	282.7 (128.5)	272.5 (123.9)														20 (6.10)
25 (7.62)	259.8 (118.1)	248.6 (113.0)	237.0 (107.7)	229.9 (104.5)												25 (7.62)
30 (9.14)	237.8 (108.1)	226.9 (103.1)	217.7 (99.0)	209.8 (95.4)	200.2 (91.0)											30 (9.14)
35 (10.67)	221.5 (100.7)	209.9 (95.4)	198.0 (90.0)	190.8 (86.7)	183.9 (83.6)	177.2 (80.5)	170.6 (77.5)									35 (10.67)
40 (12.19)	207.6 (94.4)	192.8 (87.6)	184.4 (83.8)	177.1 (80.5)	170.1 (77.3)	163.9 (74.5)	155.1 (70.5)	138.8 (63.1)	129.6 (58.9)							40 (12.19)
50 (15.24)	175.1 (79.6)	169.3 (77.0)	157.9 (71.8)	151.0 (68.6)	145.1 (66.0)	139.3 (63.3)	134.2 (61.0)	117.5 (53.4)	113.4 (51.5)	115.6 (52.5)	89.1 (40.5)	80.7 (36.7)				50 (15.24)
60 (18.29)	137.3 (62.4)	137.2 (62.4)	136.7 (62.1)	133.1 (60.5)	127.4 (57.9)	119.7 (54.4)	114.9 (52.2)	102.8 (46.7)	102.4 (46.5)	109.1 (49.6)	84.4 (38.4)	76.4 (34.7)	61.9 (28.1)	52.5 (23.9)	47.4 (21.5)	60 (18.29)
70 (21.34)	112.2 (51.0)	112.2 (51.0)	111.7 (50.8)	111.0 (50.5)	110.2 (50.1)	105.5 (48.0)	100.6 (45.7)	90.3 (41.0)	91.9 (41.8)	99.2 (45.1)	76.0 (34.5)	70.7 (32.1)	57.9 (26.3)	49.4 (22.5)	44.7 (20.3)	70 (21.34)
80 (24.38)	94.4 (42.9)	94.4 (42.9)	93.9 (42.7)	93.2 (42.4)	92.4 (42.0)	91.5 (41.6)	88.6 (40.3)	76.8 (34.9)	78.6 (35.7)	89.5 (40.7)	71.0 (32.3)	64.7 (29.4)	53.7 (24.4)	45.7 (20.8)	37.9 (17.2)	80 (24.38)
90 (27.43)		81.1 (36.9)	80.6 (36.6)	79.9 (36.3)	79.1 (36.0)	78.2 (35.5)	76.2 (34.6)	67.9 (30.9)	70.3 (32.0)	76.0 (34.5)	66.3 (30.1)	59.1 (26.9)	50.1 (22.8)	42.4 (19.3)	35.1 (16.0)	90 (27.43)
100 (30.48)		70.6 (32.1)	70.3 (32.0)	69.6 (31.6)	68.7 (31.2)	67.8 (30.8)	66.8 (30.4)	60.2 (27.4)	63.0 (28.6)	65.6 (29.8)	62.4 (28.4)	53.7 (24.4)	46.6 (21.2)	36.5 (16.6)	32.8 (14.9)	100 (30.48)
110 (33.53)			62.0 (28.2)	61.3 (27.9)	60.5 (27.5)	59.5 (27.0)	58.5 (26.6)	53.8 (24.5)	56.5 (25.7)	57.2 (26.0)	56.9 (25.9)	49.0 (22.3)	43.7 (19.9)	34.1 (15.5)	30.6 (13.9)	110 (33.53)
120 (36.58)			55.1 (25.0)	54.5 (24.8)	53.7 (24.4)	52.8 (24.0)	51.8 (23.5)	48.1 (21.9)	50.7 (23.0)	50.4 (22.9)	50.1 (22.8)	44.5 (20.2)	38.2 (17.4)	32.0 (14.5)	28.5 (13.0)	120 (36.58)
130 (39.62)				48.9 (22.2)	48.1 (21.9)	47.2 (21.5)	46.1 (21.0)	41.4 (18.8)	45.0 (20.5)	44.7 (20.3)	44.4 (20.2)	37.6 (17.1)	36.0 (16.4)	29.8 (13.5)	26.5 (12.0)	130 (39.62)
140 (42.67)				44.0 (20.0)	43.3 (19.7)	42.4 (19.3)	41.4 (18.8)	35.8 (16.3)	40.2 (18.3)	39.9 (18.1)	39.6 (18.0)	34.4 (15.6)	34.1 (15.5)	27.7 (12.6)	24.7 (11.2)	140 (42.67)
150 (45.72)					39.2 (17.8)	38.3 (17.4)	37.3 (17.0)	31.1 (14.1)	34.1 (15.5)	35.8 (16.3)	35.5 (16.1)	31.4 (14.3)	31.6 (14.4)	26.0 (11.8)	23.1 (10.5)	150 (45.72)

This material is supplied for reference use only. Operator must refer to in-cab Crane Rating Manual and Operator's Manual to determine allowable crane lifting capacities and assembly and operating procedures.

(Continued) Long Range Top – Extended Gauge (22') – 360° Rotation ABC + A [221,700 + 75,000 lb (100.3 + 34.0mt)] Cwt [All capacities are listed in kips (mt)]																
Load Radius ft (m)	Boom Length ft (m)															Load Radius ft (m)
	85 (25.91)	105 (32.00)	125 (38.10)	145 (44.20)	165 (50.29)	185 (56.39)	205 (62.48)	225 (68.58)	245 (74.68)	265 (80.77)	285 (86.87)	305 (92.96)	325 (99.06)	345 (105.2)	355 (108.2)	
160 (48.77)					35.5 (16.1)	34.7 (15.8)	33.7 (15.3)	27.2 (12.4)	30.7 (14.0)	32.2 (14.6)	31.9 (14.5)	28.6 (13.0)	29.1 (13.2)	24.2 (11.0)	21.5 (9.8)	160 (48.77)
170 (51.82)						31.6 (14.4)	30.6 (13.9)	24.0 (10.9)	27.4 (12.5)	29.1 (13.2)	28.8 (13.1)	26.1 (11.9)	26.8 (12.2)	22.7 (10.3)	20.1 (9.1)	170 (51.82)
180 (54.86)						28.7 (13.0)	27.8 (12.6)	21.1 (9.6)	24.3 (11.0)	26.4 (12.0)	26.0 (11.8)	23.7 (10.8)	24.7 (11.2)	21.1 (9.6)	18.8 (8.5)	180 (54.86)
190 (57.91)							25.1 (11.4)	19.3 (8.8)	21.4 (9.7)	23.9 (10.9)	23.6 (10.7)	21.6 (9.8)	22.6 (10.3)	19.5 (8.9)	17.6 (8.0)	190 (57.91)
200 (60.96)							22.6 (10.3)	18.0 (8.2)	18.8 (8.5)	21.7 (9.9)	21.4 (9.7)	19.7 (9.0)	20.5 (9.3)	17.8 (8.1)	16.5 (7.5)	200 (60.96)
210 (64.01)								15.8 (7.2)	16.3 (7.4)	19.7 (9.0)	19.4 (8.8)	17.7 (8.0)	18.5 (8.4)	16.3 (7.4)	15.5 (7.0)	210 (64.01)
220 (67.06)								13.4 (6.1)	13.8 (6.3)	17.9 (8.1)	17.6 (8.0)	15.8 (7.2)	16.7 (7.6)	14.8 (6.7)	14.2 (6.5)	220 (67.06)
230 (70.10)									11.2 (5.1)	16.3 (7.4)	15.9 (7.2)	14.1 (6.4)	15.1 (6.9)	13.4 (6.1)	13.0 (5.9)	230 (70.10)
240 (73.15)									8.6 (3.9)	14.2 (6.5)	14.4 (6.5)	12.5 (5.7)	13.6 (6.2)	12.3 (5.6)	11.8 (5.4)	240 (73.15)
250 (76.20)										11.8 (5.4)	13.0 (5.9)	10.9 (5.0)	12.2 (5.5)	11.0 (5.0)	10.6 (4.8)	250 (76.20)
260 (79.25)										9.1 (4.1)	11.8 (5.4)	9.3 (4.2)	10.9 (5.0)	9.9 (4.5)	9.2 (4.2)	260 (79.25)
270 (82.30)											10.5 (4.8)	7.7 (3.5)	9.8 (4.5)	8.8 (4.0)	7.9 (3.6)	270 (82.30)
280 (85.34)											9.4 (4.3)	6.2 (2.8)	8.7 (4.0)	7.7 (3.5)	6.6 (3.0)	280 (85.34)
290 (88.39)												4.6 (2.1)	7.6 (3.5)	6.7 (3.0)	5.4 (2.5)	290 (88.39)
300 (91.44)												2.9 (1.3)	6.6 (3.0)	5.7 (2.6)	4.1 (1.9)	300 (91.44)
310 (94.49)													5.3 (2.4)	4.7 (2.1)	3.0 (1.4)	310 (94.49)
320 (97.54)													3.7 (1.7)	3.8 (1.7)		320 (97.54)
330 (100.6)														2.7 (1.2)		330 (100.6)

This material is supplied for reference use only. Operator must refer to in-cab Crane Rating Manual and Operator's Manual to determine allowable crane lifting capacities and assembly and operating procedures.

# Working Range Diagram – Retracted Gauge

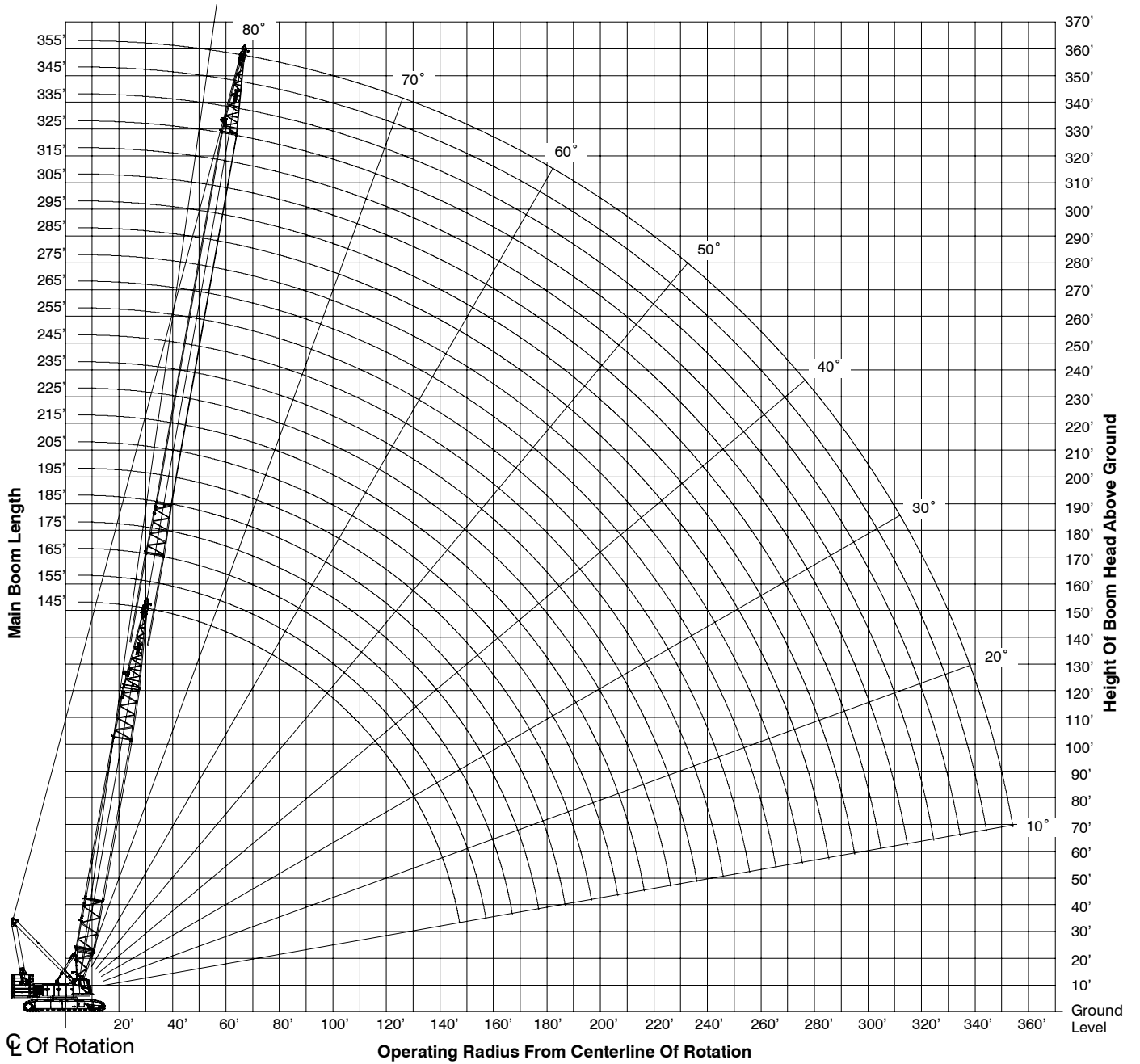

**Notes:**

1. Boom geometry shown is for unloaded condition and crane standing level on firm supporting surface. Boom deflection, subsequent radius, and boom angle change must be accounted for when applying load to hook.

# Load Chart – Retracted Gauge

**Long Range Top – Retracted Gauge (19' 2") – 360° Rotation**  
**ABC + A [221,700 + 75,000 lb (100.3 + 34.0mt)] Cwt**  
 [All capacities are listed in kips (mt)]

Load Radius ft (m)	Boom Length ft (m)															Load Radius ft (m)
	AB + A [172,150 + 75,000 lb (78.1 + 34.0mt)] Cwt						ABC + A [221,700 + 75,000 lb (100.3 + 34.0mt)] Cwt									
	85 (25.91)	105 (32.00)	125 (38.10)	145 (44.20)	165 (50.29)	185 (56.39)	205 (62.48)	225 (68.58)	245 (74.68)	265 (80.77)	285 (86.87)	305 (92.96)	325 (99.06)	345 (105.2)	355 (108.2)	
17 (5.18)	302.2 (137.4)															17 (5.18)
18 (5.49)	296.5 (134.8)															18 (5.49)
19 (5.79)	290.9 (132.2)															19 (5.79)
20 (6.10)	282.7 (128.5)	272.5 (123.9)														20 (6.10)
25 (7.62)	259.8 (118.1)	248.6 (113.0)	237.0 (107.7)	229.9 (104.5)												25 (7.62)
30 (9.14)	237.8 (108.1)	226.9 (103.1)	217.7 (99.0)	209.8 (95.4)	200.2											30 (9.14)
35 (10.67)	216.4 (98.4)	209.9 (95.4)	198.0 (90.0)	190.8 (86.7)	183.9 (83.6)	177.2 (80.5)	170.6 (77.5)									35 (10.67)
40 (12.19)	179.1 (81.4)	179.1 (81.4)	178.7 (81.2)	177.1 (80.5)	170.1 (77.3)	163.9 (74.5)	155.1 (70.5)	138.8 (63.1)	129.6 (58.9)							40 (12.19)
50 (15.24)	132.3 (60.1)	132.2 (60.1)	131.7 (59.9)	131.1 (59.6)	130.4 (59.3)	129.6 (58.9)	134.2 (61.0)	117.5 (53.4)	113.4 (51.5)	115.6 (52.5)	89.1 (40.5)	67.2 (30.5)				50 (15.24)
60 (18.29)	104.1 (47.3)	104.0 (47.3)	103.5 (47.0)	102.8 (46.7)	102.0 (46.4)	101.1 (46.0)	114.9 (52.2)	102.8 (46.7)	102.4 (46.5)	109.1 (49.6)	84.4 (38.4)	63.2 (28.7)	50.7 (23.0)	52.5 (23.9)	47.4 (21.5)	60 (18.29)
70 (21.34)	85.2 (38.7)	85.1 (38.7)	84.6 (38.5)	83.8 (38.1)	83.0 (37.7)	82.1 (37.3)	97.0 (44.1)	90.3 (41.0)	91.9 (41.8)	96.0 (43.6)	76.0 (34.5)	59.3 (27.0)	47.2 (21.5)	49.4 (22.5)	44.7 (20.3)	70 (21.34)
80 (24.38)	71.5 (32.5)	71.5 (32.5)	71.0 (32.3)	70.3 (32.0)	69.4 (31.5)	68.5 (31.1)	81.1 (36.9)	76.8 (34.9)	78.6 (35.7)	79.9 (36.3)	71.0 (32.3)	55.0 (25.0)	43.5 (19.8)	45.7 (20.8)	37.9 (17.2)	80 (24.38)
90 (27.43)		61.3 (27.9)	60.8 (27.6)	60.1 (27.3)	59.2 (26.9)	58.2 (26.5)	69.1 (31.4)	67.9 (30.9)	68.1 (31.0)	67.9 (30.9)	66.3 (30.1)	51.2 (23.3)	36.7 (16.7)	42.4 (19.3)	35.1 (16.0)	90 (27.43)
100 (30.48)		53.2 (24.2)	52.8 (24.0)	52.1 (23.7)	51.2 (23.3)	50.3 (22.9)	59.8 (27.2)	58.9 (26.8)	58.8 (26.7)	58.5 (26.6)	58.2 (26.5)	47.7 (21.7)	34.3 (15.6)	36.5 (16.6)	32.8 (14.9)	100 (30.48)
110 (33.53)			46.4 (21.1)	45.7 (20.8)	44.8 (20.4)	43.9 (20.0)	52.4 (23.8)	51.4 (23.4)	51.2 (23.3)	51.0 (23.2)	50.6 (23.0)	44.7 (20.3)	32.2 (14.6)	34.1 (15.5)	30.6 (13.9)	110 (33.53)
120 (36.58)			41.0 (18.6)	40.4 (18.4)	39.6 (18.0)	38.6 (17.5)	46.3 (21.0)	45.3 (20.6)	45.1 (20.5)	44.8 (20.4)	44.5 (20.2)	39.1 (17.8)	30.4 (13.8)	32.0 (14.5)	28.5 (13.0)	120 (36.58)
130 (39.62)				36.0 (16.4)	35.2 (16.0)	34.2 (15.5)	41.1 (18.7)	40.2 (18.3)	40.0 (18.2)	39.7 (18.0)	39.3 (17.9)	37.0 (16.8)	28.6 (13.0)	29.8 (13.5)	26.5 (12.0)	130 (39.62)
140 (42.67)				32.2 (14.6)	31.4 (14.3)	30.5 (13.9)	36.8 (16.7)	35.8 (16.3)	35.6 (16.2)	35.3 (16.0)	34.9 (15.9)	34.5 (15.7)	26.9 (12.2)	27.7 (12.6)	24.7 (11.2)	140 (42.67)
150 (45.72)					28.2 (12.8)	27.3 (12.4)	33.1 (15.0)	31.1 (14.1)	31.9 (14.5)	31.6 (14.4)	31.2 (14.2)	30.8 (14.0)	25.4 (11.5)	26.0 (11.8)	23.1 (10.5)	150 (45.72)

This material is supplied for reference use only. Operator must refer to in-cab Crane Rating Manual and Operator's Manual to determine allowable crane lifting capacities and assembly and operating procedures.

(Continued) Long Range Top – Retracted Gauge (19' 2") – 360° Rotation ABC + A [221,700 + 75,000 lb (100.3 + 34.0mt)] Cwt [All capacities are listed in kips (mt)]																
Load Radius ft (m)	Boom Length ft (m)															Load Radius ft (m)
	AB + A [172,150 + 75,000 lb (78.1 + 34.0mt)] Cwt						ABC + A [221,700 + 75,000 lb (100.3 + 34.0mt)] Cwt									
	85 (25.91)	105 (32.00)	125 (38.10)	145 (44.20)	165 (50.29)	185 (56.39)	205 (62.48)	225 (68.58)	245 (74.68)	265 (80.77)	285 (86.87)	305 (92.96)	325 (99.06)	345 (105.2)	355 (108.2)	
160 (48.77)					25.3 (11.5)	24.5 (11.1)	29.8 (13.5)	27.2 (12.4)	28.6 (13.0)	28.3 (12.9)	27.9 (12.7)	27.5 (12.5)	24.1 (11.0)	24.2 (11.0)	21.5 (9.8)	160 (48.77)
170 (51.82)						22.0 (10.0)	27.0 (12.3)	24.0 (10.9)	25.8 (11.7)	25.5 (11.6)	25.1 (11.4)	24.7 (11.2)	23.0 (10.5)	22.7 (10.3)	20.1 (9.1)	170 (51.82)
180 (54.86)						19.8 (9.0)	24.5 (11.1)	21.1 (9.6)	23.2 (10.5)	22.9 (10.4)	22.6 (10.3)	22.2 (10.1)	21.7 (9.9)	20.7 (9.4)	18.8 (8.5)	180 (54.86)
190 (57.91)							22.2 (10.1)	19.3 (8.8)	21.0 (9.5)	20.7 (9.4)	20.3 (9.2)	19.9 (9.0)	19.4 (8.8)	18.5 (8.4)	17.6 (8.0)	190 (57.91)
200 (60.96)							20.1 (9.1)	18.0 (8.2)	18.8 (8.5)	18.7 (8.5)	18.3 (8.3)	17.9 (8.1)	17.4 (7.9)	16.5 (7.5)	16.2 (7.4)	200 (60.96)
210 (64.01)								15.8 (7.2)	16.3 (7.4)	16.9 (7.7)	16.5 (7.5)	16.1 (7.3)	15.6 (7.1)	14.6 (6.6)	14.4 (6.5)	210 (64.01)
220 (67.06)								13.4 (6.1)	13.8 (6.3)	15.2 (6.9)	14.9 (6.8)	14.4 (6.5)	14.0 (6.4)	13.0 (5.9)	12.7 (5.8)	220 (67.06)
230 (70.10)									11.2 (5.1)	13.7 (6.2)	13.3 (6.0)	12.9 (5.9)	12.5 (5.7)	11.5 (5.2)	11.2 (5.1)	230 (70.10)
240 (73.15)									8.6 (3.9)	12.3 (5.6)	12.0 (5.5)	11.6 (5.3)	11.1 (5.0)	10.1 (4.6)	9.9 (4.5)	240 (73.15)
250 (76.20)										11.0 (5.0)	10.7 (4.9)	10.3 (4.7)	9.8 (4.5)	8.9 (4.0)	8.6 (3.9)	250 (76.20)
260 (79.25)										9.1 (4.1)	9.5 (4.3)	9.1 (4.1)	8.7 (4.0)	7.7 (3.5)	7.4 (3.4)	260 (79.25)
270 (82.30)											8.4 (3.8)	8.0 (3.6)	7.6 (3.5)	6.6 (3.0)	6.4 (2.9)	270 (82.30)
280 (85.34)											7.3 (3.3)	7.0 (3.2)	6.6 (3.0)	5.6 (2.5)	5.4 (2.5)	280 (85.34)
290 (88.39)												6.0 (2.7)	5.6 (2.5)	4.7 (2.1)	4.4 (2.0)	290 (88.39)
300 (91.44)													5.1 (2.3)	4.7 (2.1)	3.6 (1.6)	300 (91.44)
310 (94.49)														3.9 (1.8)	2.7 (1.2)	310 (94.49)
320 (97.54)														3.1 (1.4)	2.2 (1.0)	320 (97.54)

This material is supplied for reference use only. Operator must refer to in-cab Crane Rating Manual and Operator's Manual to determine allowable crane lifting capacities and assembly and operating procedures.

**Link-Belt Construction Equipment Company** Lexington, Kentucky [www.linkbelt.com](http://www.linkbelt.com)

®Link-Belt is a registered trademark. Copyright 2007. We are constantly improving our products and therefore reserve the right to change designs and specifications.